

Manual for wire and flexible level sensors and controllers

Covers: HBLT & HBSLT

- Wire sensor suited for liquids like NH₃, water, HFC/HFO refrigerants
- Flex sensor suited for liquids like CO₂ and Hydro carbons

Can be used in refrigeration systems and similar demanding systems.

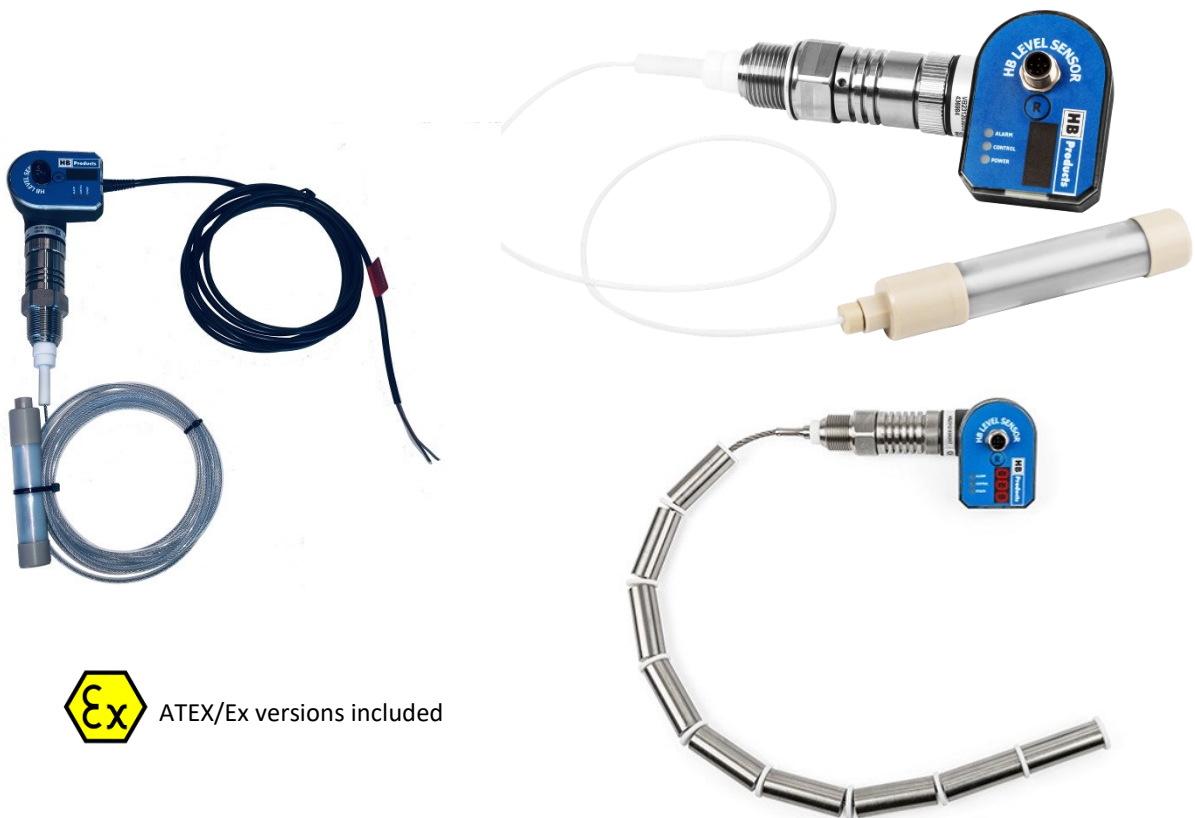

Introduction

Wire and Flex are intelligent liquid level sensors which can be installed in a vessel or in a standpipe. For the Wire sensor the sensor element is a stainless steel wire insulated with PTFE and for the Flex sensor the element is a stainless steel wire mounted with steel tube elements to increase the sensitivity. Both sensors can to be mounted directly in a stand pipe. If they need to be installed in a vessel they need an inner pipe. Both sensors measure between the wire/tube elements and the surrounding pipe.

The sensor can be installed in refrigeration systems and similar demanding applications with high pressures and aggressive fluids. The sensor emits a 4-20mA analog signal, which is proportional to the liquid level.



Table of contents

Introduction 1
 Safety Instructions 2
 Application Examples 3-5
 Installation Wire 6
 Installation Flex 7
 Connection diagrams 8-12
 Analog output 12
 Use the HB-tool for setting up the sensor 13-16
 LED indication 17
 Calibration on the sensor 17
 Fault detection 18
 Sensor Repair 18
 Further Information 18

Safety Instructions

CAUTION! Always read the instruction manual before commencing work! Heed all warnings to the letter! Installation of the sensor requires technical knowledge of both refrigeration and electronics. Only qualified personnel should work with the product. The technician must be aware of the consequences of an improperly installed sensor and must be committed to adhering to the applicable local legislation.

If changes are made to type-approved equipment, this type approval becomes void. The product's input and output, as well as its accessories, may only be connected as shown in this guide. HB Products assumes no responsibility for damages resulting from not adhering to the above.

Explanation of the symbol for safety instructions. In this guide, the symbol below is used to point out important safety instructions for the user. It will always be found in places in the chapters where the information is relevant. The safety instructions and the warnings in particular, must always be read and adhered to.

	CAUTION! Refers to a possible limitation of functionality or risk in usage.
	NOTE! Contains important information about the product and provides further tips.
	The person responsible for operation must commit to adhering to all the legislative requirements, preventing accidents, and doing everything to avoid damage to people and materials.

Intended use, conditions of use. The level sensor is designed for continuous measurement of liquids, but please note the sensor design and setup has to comply with the liquid. The table show how sensors comply to liquids. It can be used in refrigeration systems and similar environments. If the sensor is to be used in a different way and if the operation of the product in this function is determined to be problematic, prior approval must be obtained from HB Products.

Prevention of collateral damage Make sure that qualified personnel assess any errors and take necessary precautions before attempting to make replacements or repairs, to avoid collateral damage.

Disposal instructions: The sensor is constructed so that the modules can easily be removed and sorted for disposal.

- Comply
- Not comply

Products	HFC, HFO	Oil, Hydrocarbons, CO2	NH3, Water, Alcohols
HBLC-Fgas	<input checked="" type="radio"/>	<input checked="" type="radio"/>	<input type="radio"/>
HBLC & HBSLC-CO2 HBLC & HBSLC-Oil HBLC & HBSLC-HFC	<input checked="" type="radio"/>	<input checked="" type="radio"/>	<input type="radio"/>
HBLC & HBSLC	<input type="radio"/>	<input type="radio"/>	<input checked="" type="radio"/>
HBLT & HBSLT-A2 & A3	<input type="radio"/>	<input type="radio"/>	<input checked="" type="radio"/>
HBLT-A1/AKS41	<input type="radio"/>	<input type="radio"/>	<input checked="" type="radio"/>
HBLT & HBSLT-Flex	<input checked="" type="radio"/>	<input checked="" type="radio"/>	<input type="radio"/>
HBLT & HBSLT-Wire	<input checked="" type="radio"/>	<input type="radio"/>	<input checked="" type="radio"/>

Installation Instructions—wire sensor

The wire sensor is designed for level measurement of liquids in vessels like, tanks, pump separators and receivers . The sensor can be mounted in a standpipe from 1" (25mm) up to 4" (100mm) diameter or directly in a vessel with an inner pipe from 1" (25mm) up to 4" (100mm) diameter. The inner pipe is needed to create sufficient measuring signal and to avoid a swinging wire in a lively fluid. To reduce wire movements in larger pipes a special weight can be used.

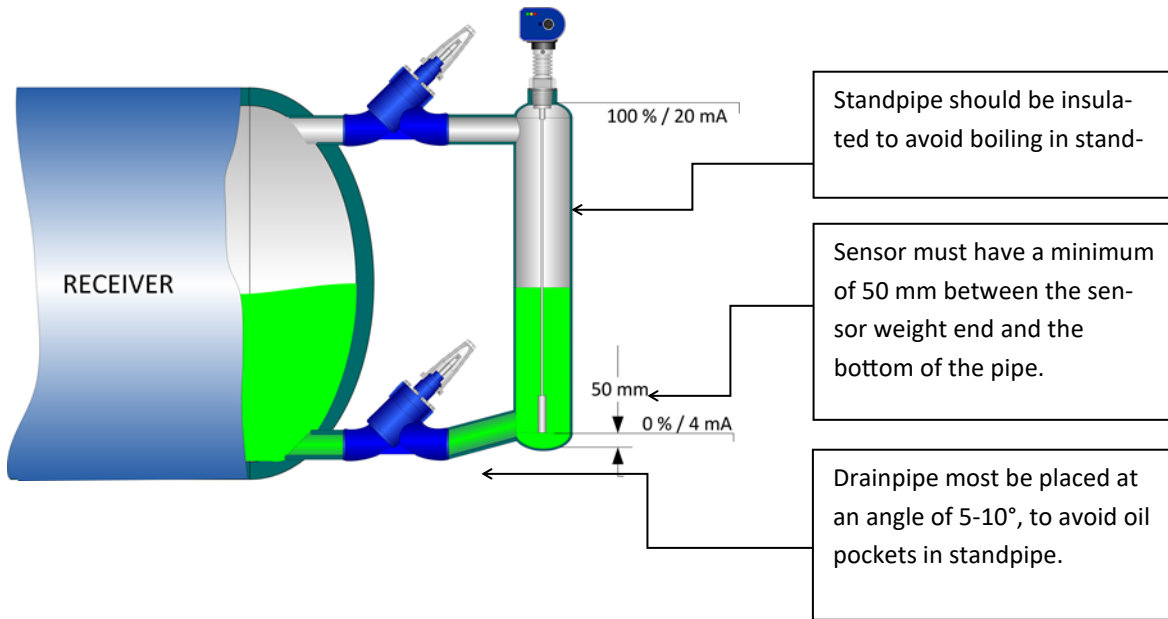

The following applies to the design of the system:

- It must be installed in a vertical position
- Sensor must have a minimum of 50 mm between the sensor weight end and the bottom of the pipe.
- The sensor must be installed in an overflow or standpipe where the flow stream and turbulence are minimized.
- The sensor must be mounted in a standpipe bigger than DN25. Standpipe must be insulated to avoid boiling of refrigerant.
- The outlet pipe from standpipe shall be mounted in an angle of 5-10 degree from horizontal to secure drainage and oil pockets in refrigeration systems.
- The sensor is installed and is supplied with a standard non-shielded cable.
If EMC is greater than described in EN 61326, a shielded cable must be used.

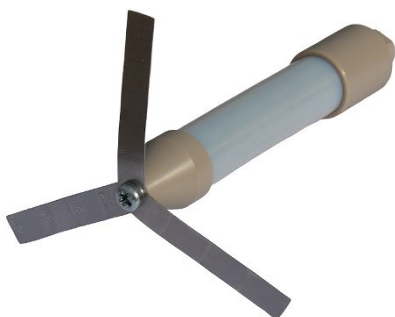

Special weight for mounting in turbulent conditions. The steel spacer "star" can be shortened, using a simple tin cutting shear, to fit the standpipe. Allow 2 mm play between inner pipe diameter and "star" diameter

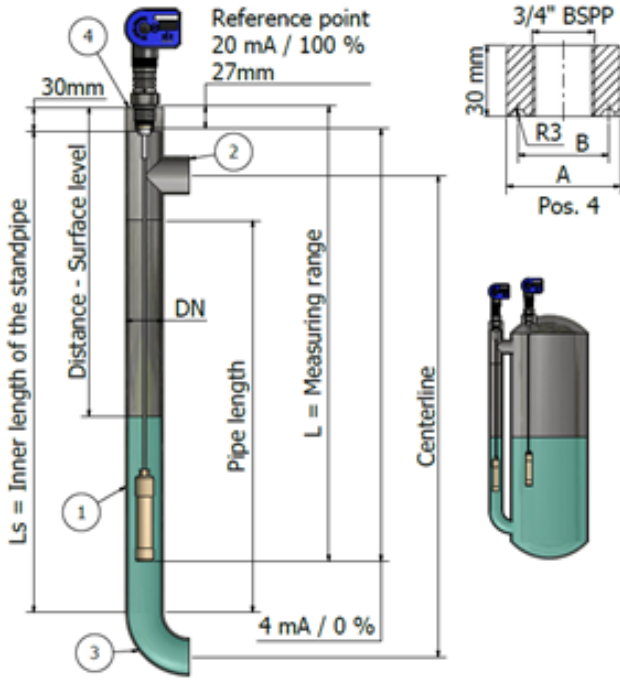

Stand pipe: DN32.....DN65.

Recommended pipe standard: DIN 10220

Recommended bending: DIN 2615-1/Type 3

Recommended TEE: DIN 2615-1

Standpipe: DN65...DN100.

Recommended pipe standard: DIN 10220

Recommended bending: DIN 2615-1/Type 3

Site pipe can be designed in smaller pipe e.g. 0.5 x DN.

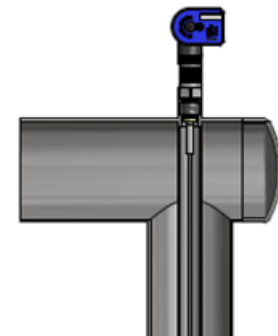
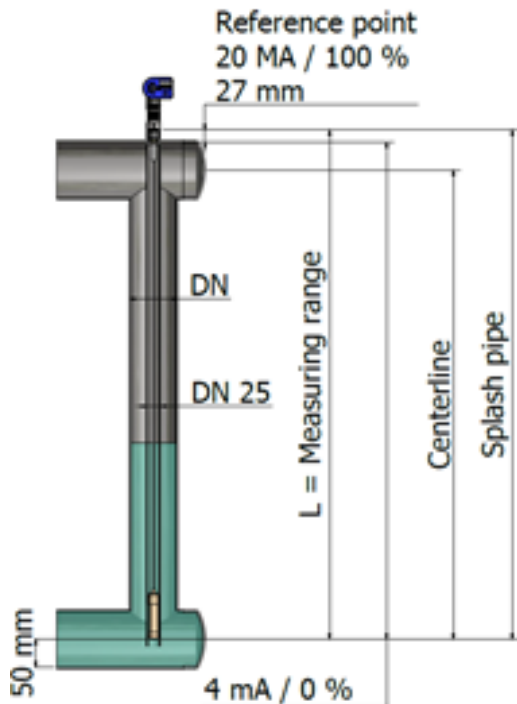
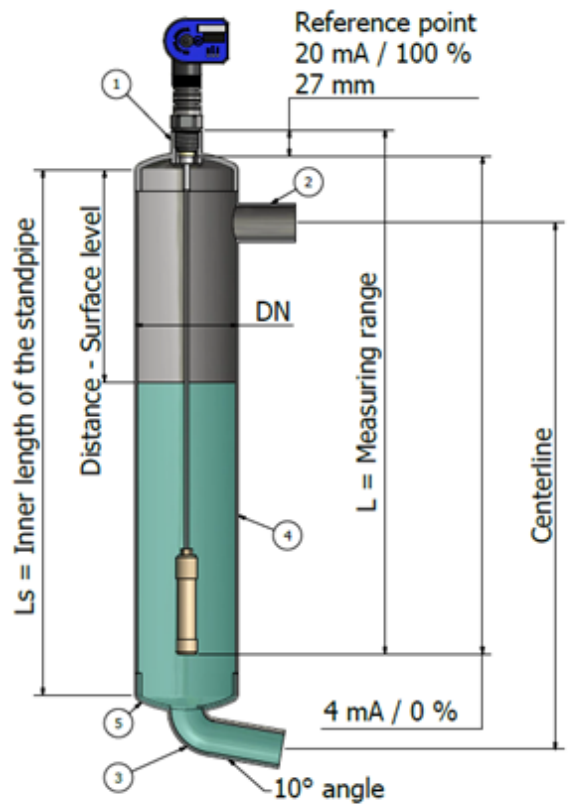

Installation Instructions—Flex sensor

The Flex sensor is designed for level measurement of liquids in vessels like, tanks, pump separators and receivers . The sensor can be mounted in a standpipe 1" (25mm) or 1 ¼" (32mm) diameter or directly in a vessel with an inner pipe 1" (25mm) or 1 ¼" (32mm) diameter. The inner pipe is needed to create sufficient measuring signal and to avoid a swinging wire in a lively fluid.

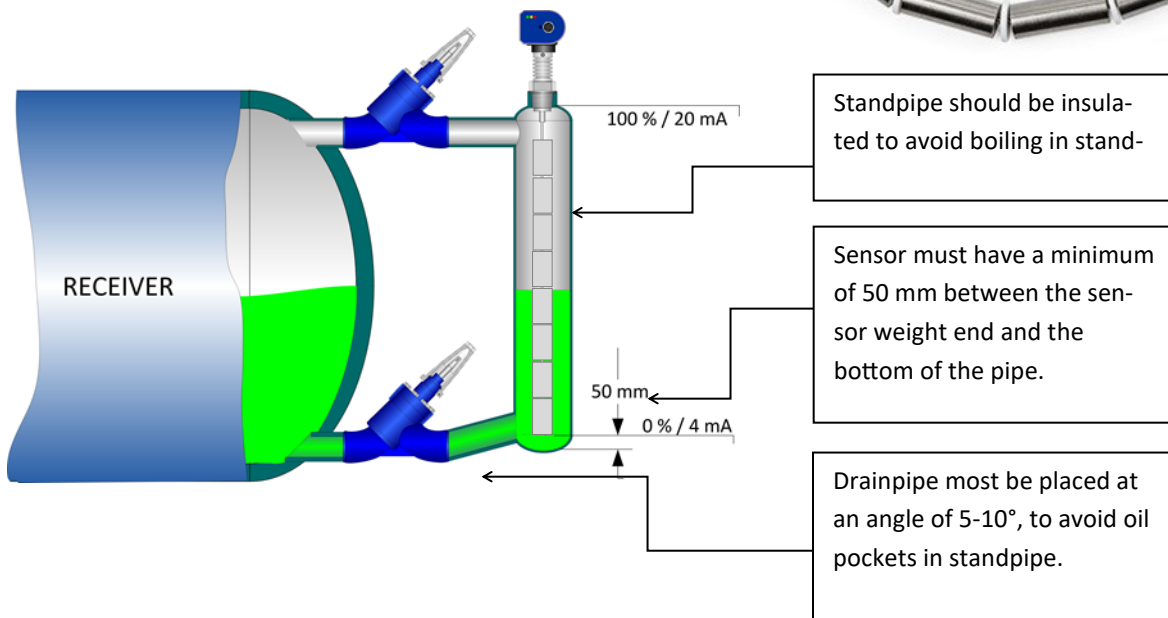

The following applies to the design of the system:

- It must be installed in a vertical position
- Sensor must have a minimum of 50 mm between the sensor weight end and the bottom of the pipe.
- The sensor must be installed in an overflow or standpipe where the flow stream and turbulence are minimized.
- The sensor must be mounted in a standpipe DN25 or DN32. The standpipe must be insulated to avoid boiling of refrigerant.
- The outlet pipe from standpipe shall be mounted in an angle of 5-10 degree from horizontal to secure drainage and oil pockets in refrigeration systems.
- The sensor is supplied and can be is installed with a standard non-shielded cable.
If EMC is greater than described in EN 61326, a shielded cable must be used.

Wire adjustment—Wire sensor

The sensor is installed in the standpipe or directly in the tank. The sensor length is determined by standpipe length or tank height. Cut the insulated steel wire to desired length with a wire cutters or bolt cutter in the end where the weight is installed. The weight is fixed by the 2 screws. Liquid sealant is applied to the thread.

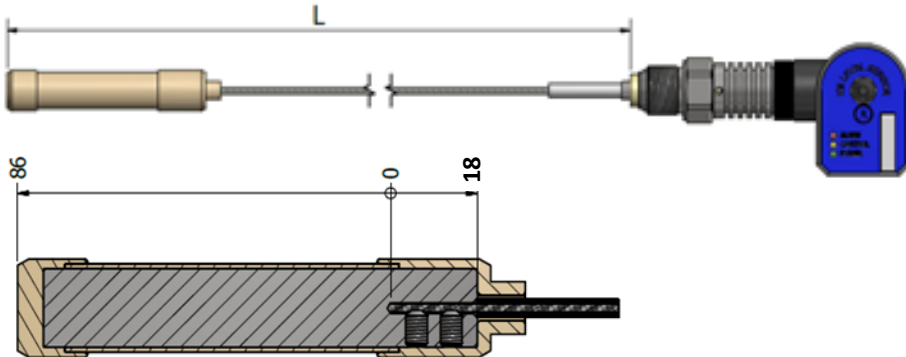

L = Programmable sensor length
L = Wire length + 86 mm

Allow for 50 mm clearance below the weight to the bottom of the tank—if relevant.



To install HBLT-wire, you must use a 2.5 mm Allen key, shifting spanner, and gasket, depending on the type of thread.

Separate the electronic part from the mechanical part

Define the required length of sensor from standpipe. Shorten the wire with wire cutter.



Remove the insulation 18 +/-2 mm

Make sure that wire is in bottom of the hole.

Tighten the 2 set screws to fix the wire. Turn the top cover plastic part on the metal part (right-hand thread)

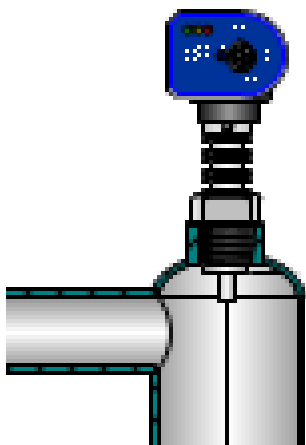

When sealing the conical thread, you must use liquid conductive sealant, which creates a ground connection between the standpipe/tank and the sensor, since the sensor uses the standpipe/tank as reference. If Teflon is used, it must only be used on part of the thread so that the ground connection is established. If you are in doubt regarding the ground connection, measuring the resistance between the tank and sensor is recommended. This should be approx. 0 ohms.

An aluminum sealing/washer has been included for the sensor with cylindrical thread.

Installation instruction—Flex sensor

The sensor can be shortened to fit the standpipe length or vessel height. The sensor consist of a 5 mm steel wire fitted with a stainless steel weight at the bottom, plastic spacers and aluminum pipes. The purpose of the plastic spacers is to keep the metal parts away from the pipe and the aluminum pipe increase the sensitivity of the sensor.



The sensor with all elements removed from the wire. To shorten HBSLT/HBLT-Flex, you only need to remove the necessary elements. A large wire cutter is needed for the wire.



The sensor length can be reduced to desired length by reducing the wire length and removing the aluminum pipes and spacers. Shorten the wire by using a heavy wire cutter or bolt cutter in the end where the weight is installed.

Allow for the wire to be inserted 25 mm into the weight and a 50 mm clearance below the weight to the bottom of the vessel. You can have up to 50 mm free wire at the top or shorten one of the aluminum pieces to get to the desired length.

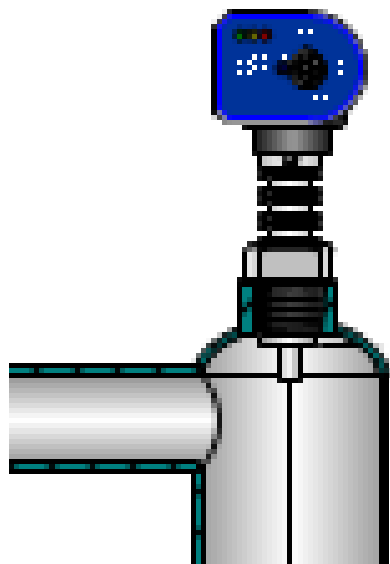

When sealing the conical thread, you must use liquid conductive sealant, which creates a ground connection between the standpipe/tank and the sensor, since the sensor uses the standpipe/tank as reference. If Teflon is used, it must only be used on part of the thread so that the ground connection is established. If you are in doubt regarding the ground connection, measuring the resistance between the tank and sensor is recommended. This should be approx. 0 ohms.

An aluminum sealing/washer has been included for the sensor with cylindrical thread.

How to connect the sensor

Two different type of sensors

- A pure sensor version with 4-20 mA output
- A controller version with both cable for direct valve control and analog output

All sensors can provide a signal for a PLC via the M12 connection. The M12 connection is also used for power supply. Some versions are able to control a valve directly. They have a cable, which can be connected directly to the valve.



Connection diagram for sensors without control cable. With and without temperature compensation

Suited for

- HBLT and HBLT-wire & Flex
- HBLC

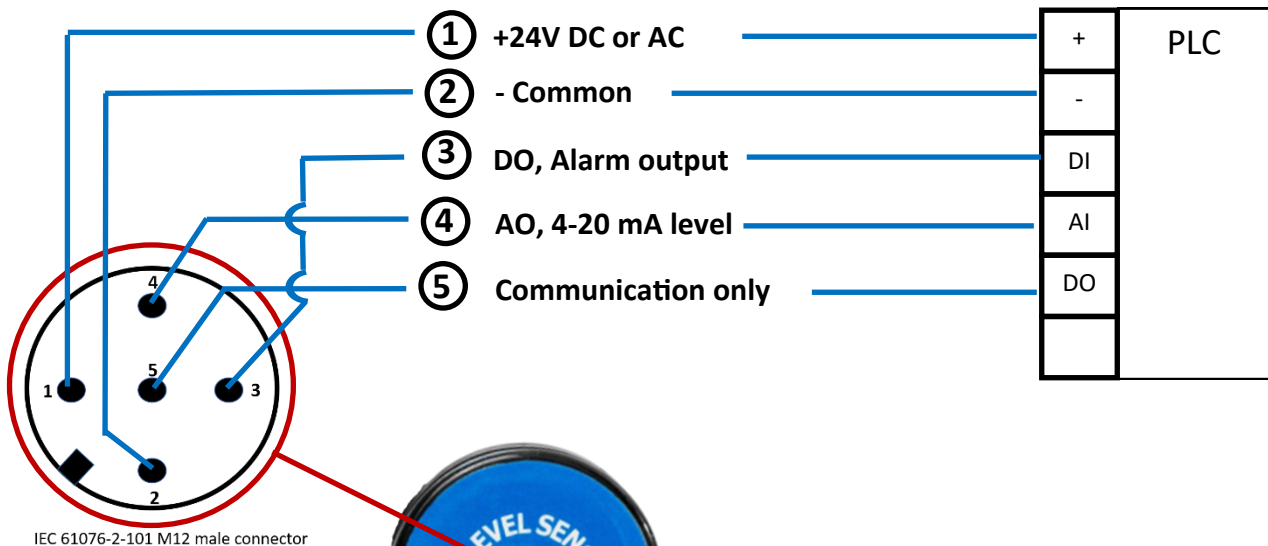

M12 Cable, wire Colour

- 1 = Brown
- 2 = White
- 3 = Blue
- 4 = Black
- 5 = Gray

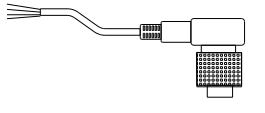

Digital output on pin 3

The sensor versions without a cable has an alarm output on pin 3. Remote setpoint is not available

Connection diagram for sensors with control cable for all common stepper motor valves — here shown with Carel E2V

Suited for

- HBSLT/S and HBSLT-wire & Flex/S
- HBSLC/S

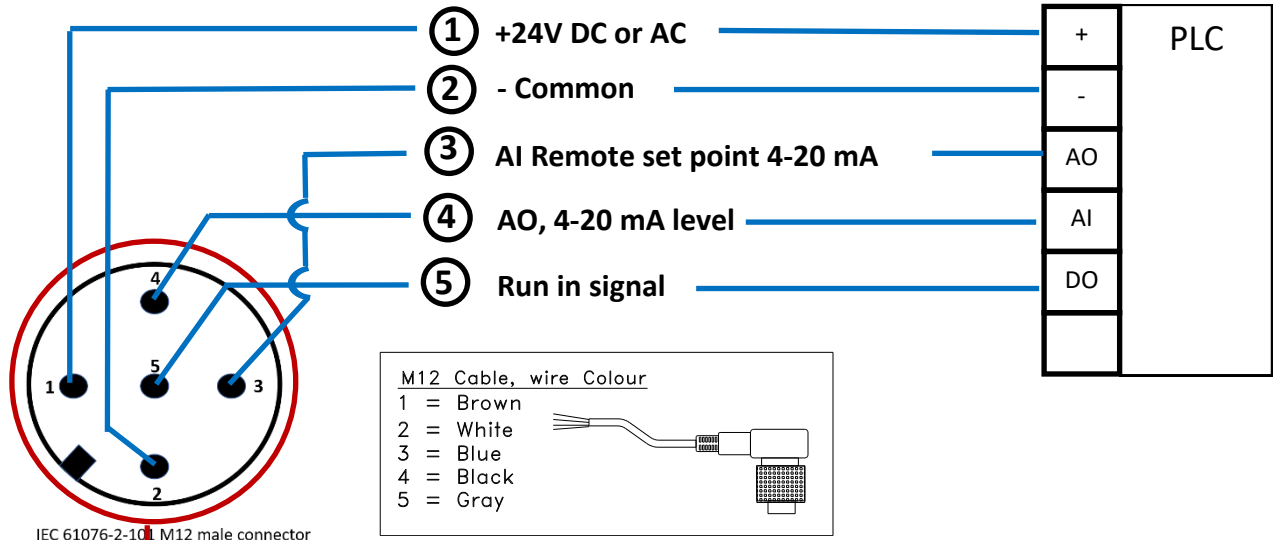

IEC 61076-2-101 M12 male connector



The sensor has a built in controller for a stepper valve. The sensor provides both the analog output via the cable to control the valve. The level measurement signal for the PLC comes via the M12 plug .

On pin 3 it is possible to send an analog 4-20 mA signal to the controller and change the setpoint. The signal is scaled linear like analog output.

The cable is connected according to the drawing and the parameters are set as shown in the next section.

For the stepper motor setup a special menu is activated

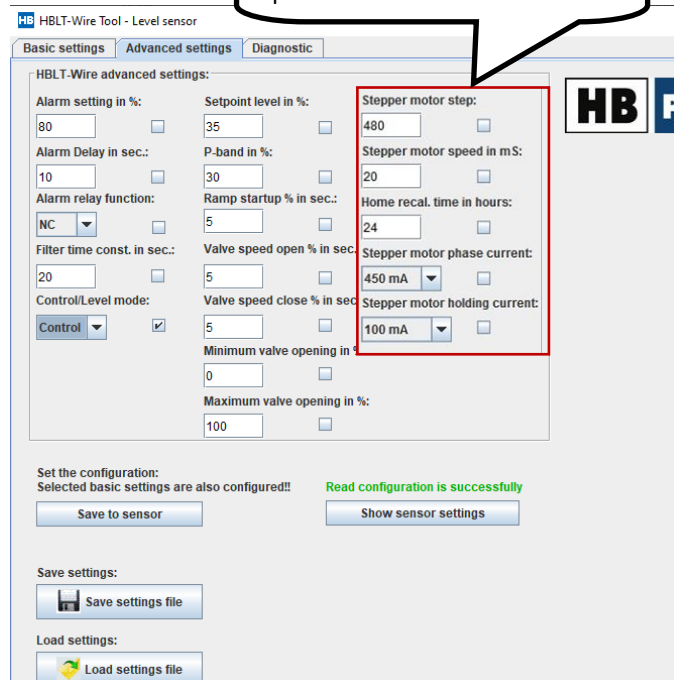

- Color coding
- A+ = yellow(2)
 - A- = white (4)
 - B- = green (1)
 - B+= brown (3)

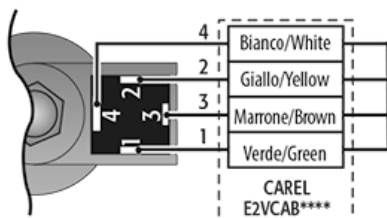

Connection diagram for sensors with control cable for pulse modulating valve — here shown with Danfoss AKV/AKVA

Suited for

- HBSLT/PWM and HBSLT-wire & Flex/PWM
- HBSLC/PWM

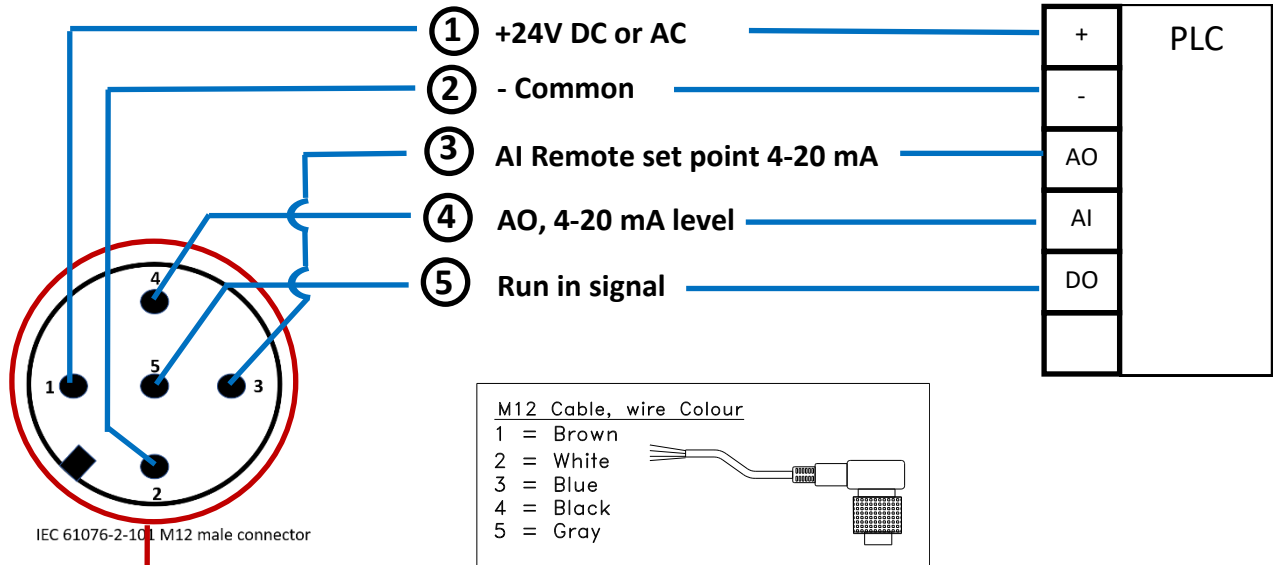

The sensor has a built in controller for a pulse modulating valve. The sensor provides both the analog output via the cable to control the valve. The level measurement signal for the PLC comes via the M12 plug .

On pin 3 it is possible to send an analog 4-20 mA signal to the controller and change the setpoint. The signal is scaled linear like analog output.

The cable is connected according to the drawing and the parameters are set as shown in the next section.

Wiring using cable

Brown: + when using DC

White: - common when using DC

The cable can supply AC as well



Connection diagram for sensors with control cable for modulating valve — here shown with Siemens MVS661

Suited for

- HBSLT/C and HBSLT-wire & Flex/C
- HBLC/C

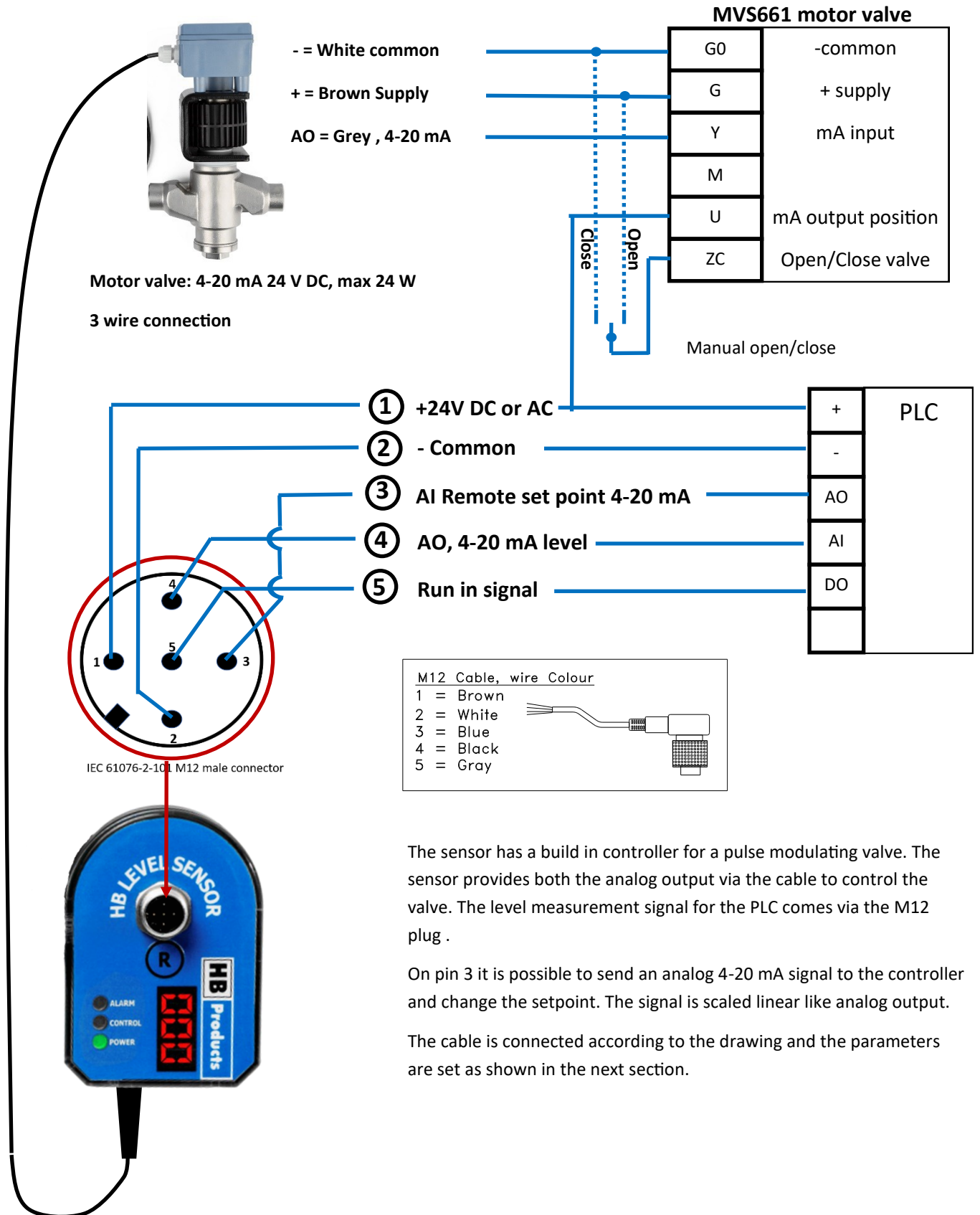

The sensor has a built in controller for a pulse modulating valve. The sensor provides both the analog output via the cable to control the valve. The level measurement signal for the PLC comes via the M12 plug .

On pin 3 it is possible to send an analog 4-20 mA signal to the controller and change the setpoint. The signal is scaled linear like analog output.

The cable is connected according to the drawing and the parameters are set as shown in the next section.

Connection diagram for sensors without control cable. With and without temperature compensation

Suited for

- HBLT and HBLT-wire & Flex
- HBLC

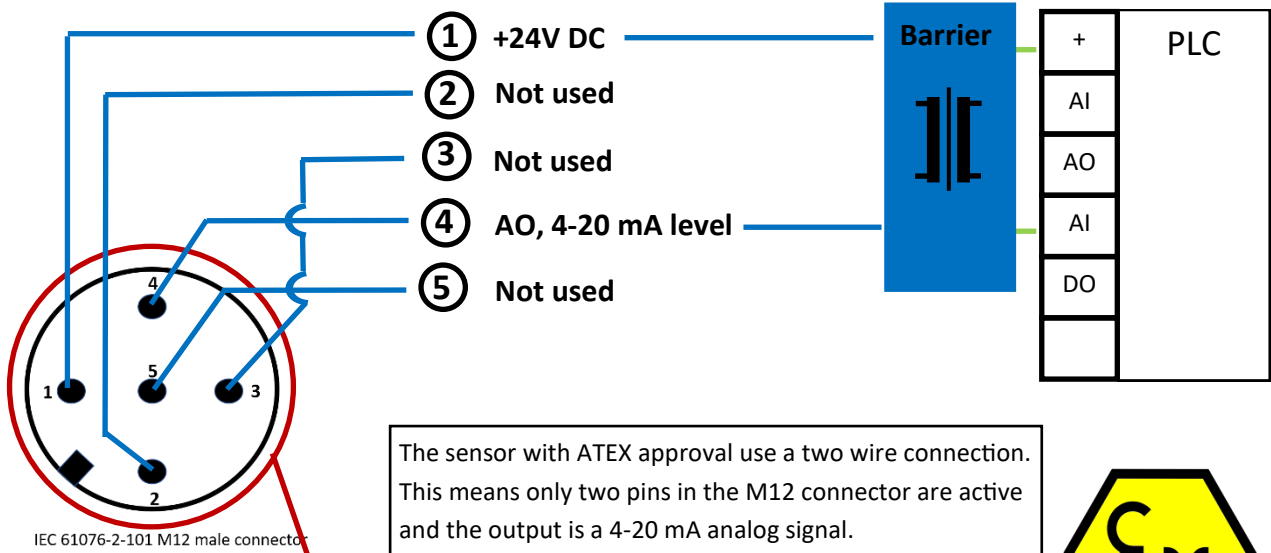

The sensor with ATEX approval use a two wire connection. This means only two pins in the M12 connector are active and the output is a 4-20 mA analog signal.



Scaling and offsetting the output

Scaling the analog output

The output is scaled linear from minimum to maximum and it is done in the HB-tool.

Offsetting minimum and maximum

If your sensor height doesn't match your vessel height it is possible to move the minimum level and maximum level beyond the physical sensor by adjusting the offset value in the HB-tool. It is also possible to make the offset by making a calibrations to known levels also in the tool.

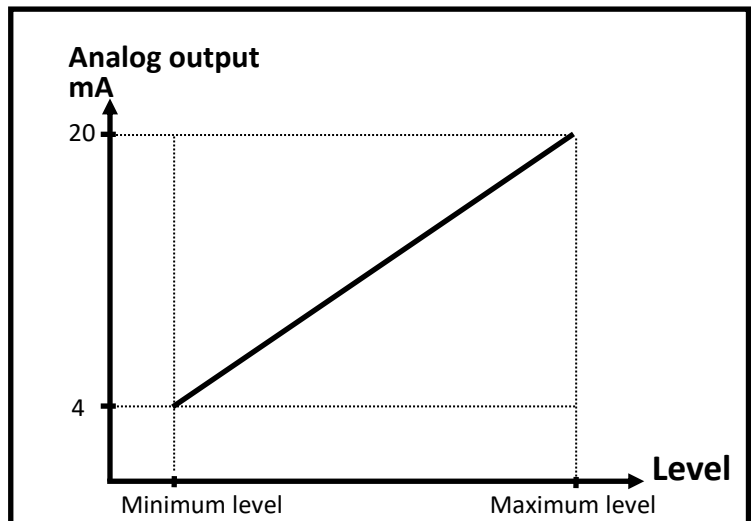

Use the HB tool for setting up the sensor

Setup — level or control

The sensor can operate in two different modes

- As sensor input to a PLC, computer or other device that uses the analog sensor signal
- A direct controller of an electrically controlled expansion valve version with a cable output that can be set up as a controller

Select Control/Level to select the mode

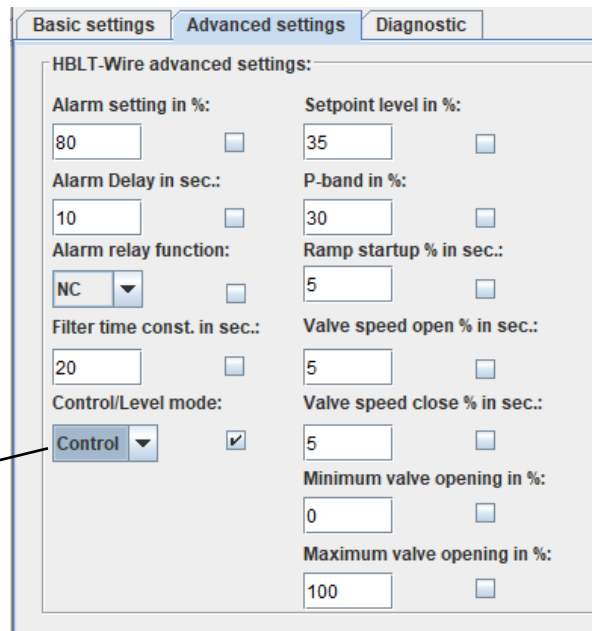
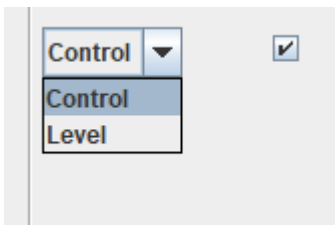

Setting up the sensor

The HB tool has three pages of settings. Some fields will be shown in grey when they are not relevant/active with the setting chosen. Detailed explanations of the individual fields will show up when the mouse is moved over the field. Only the latest version of the tool has this feature.

When you like to change a setting, you just type in a new value or select in the drop down. After changing the value you store the data by clicking "save to sensor". The data is then saved and stored in the sensor and remains there even when the power supply is disconnected.

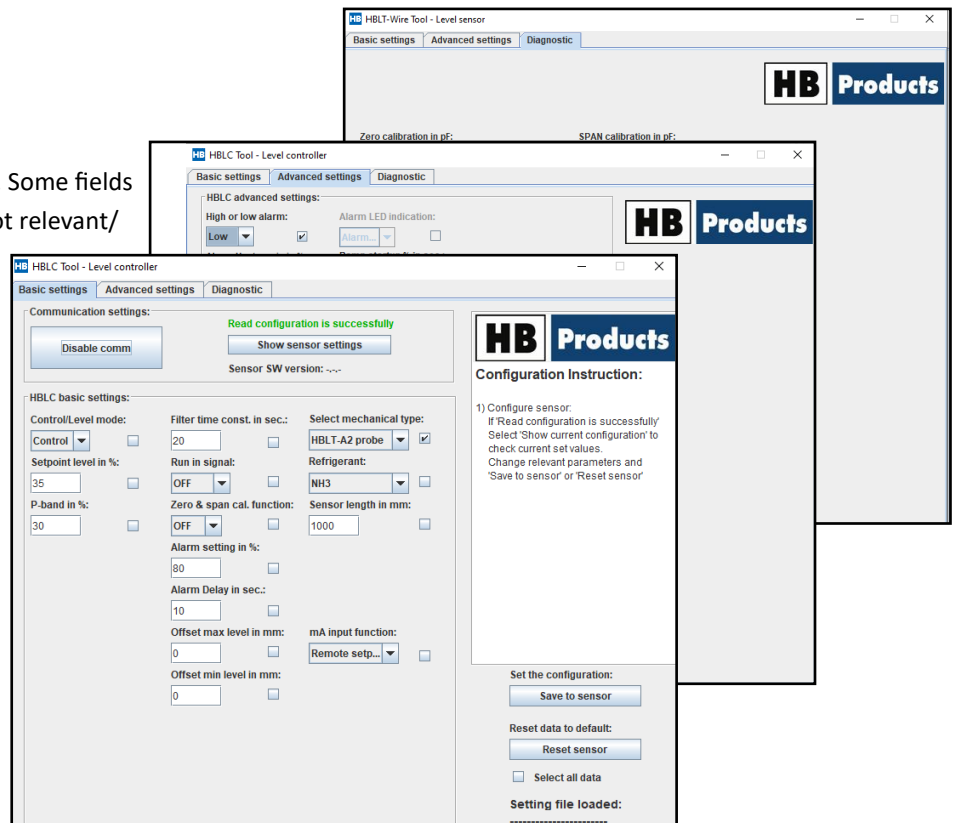

Connecting the sensor

All sensor are connected to a PC using an USB/M12 cable

Setup using a splitter box

When using a splitter box it is possible to run the refrigeration system and connect a PC to the sensor at the same time. The splitter box is not suited for normal operation, but only for installation and modification. The splitter box is connected to the M12 plug on the HBX sensor and then both the pc and the normal M12 plug can be connected.



The USB cable and the splitter box

Basic settings

Here you make the primary settings of the sensor

The screenshot shows the 'Basic settings' tab of the HBLC Tool. The interface includes a 'Communication settings' section with a 'Disable comm' button and a 'Show sensor settings' button. Below this is the 'HBLC basic settings' section, which contains several fields and dropdown menus. Callouts provide detailed explanations for these settings:

- Control/Level mode:** A dropdown menu set to 'Control'. Callout: "Here you set the parameters for the control function. When 'Run in signal' is set to off the sensor control continuously when set to on, control only when signal is applied on pin5".
- Setpoint level in %:** A text input field with the value '35'. Callout: "Here you set the alarm level. This is only for versions without cable for valve control".
- P-band in %:** A text input field with the value '30'. Callout: "Here you can adjust minimum and maximum".
- Filter time const. in sec.:** A text input field with the value '20'. Callout: "Filter time averages the output over a period and reduce fluctuations".
- Run in signal:** A dropdown menu set to 'OFF'. Callout: "Here you set the parameters for the sensor".
- Zero & span cal. function:** A dropdown menu set to 'OFF'. Callout: "Zero & span. When off is selected the 'R' button can't be used".
- Alarm setting in %:** A text input field with the value '80'. Callout: "Select remote setpoint if you use that." (referring to the 'mA input function' dropdown).
- Alarm Delay in sec.:** A text input field with the value '10'.
- Offset max level in mm:** A text input field with the value '0'.
- Offset min level in mm:** A text input field with the value '0'.
- Select mechanical type:** A dropdown menu set to 'HBLT-A2 probe'. Callout: "Here you set the parameters for the sensor".
- Refrigerant:** A dropdown menu set to 'NH3'.
- Sensor length in mm:** A text input field with the value '1000'.
- mA input function:** A dropdown menu set to 'Remote setp...'. Callout: "Select remote setpoint if you use that."

Setpoint level in % (control mode only) Desired level: Shows the percentage level that one wants to remain in the container or the level indicator.

P-band in % (control mode only) Proportional band: Control area that describes how much the valve should open, dependent upon the deviation from the desired level. If proportional band is set to 10%, for example, a liquid level that is under 5% will make the valve open 50%; the valve will open to 100% if the level is under 10%. Small proportional band results in a system which reacts quickly, while a large proportional band results in a system that reacts more slowly.

Filter time const. in sec. Filter function: Averages the measurement so that the control function is performed based on an average measurement in a programmable time span (in seconds). This is increased if there are brief fluctuations in the measurement which lead to unstable control.

Run in signal remote activation: with this function it is possible to activate centralized control. If one does not want this, the function must be set to OFF, otherwise the sensor's control function will not work (power LED will flash when run-in signal is active or if this function is deactivated).

Zero & span cal. Function Calibrating function: ON in case calibration of the sensor is allowed. After start-up and possibly the first calibration, the tool can be connected and is deactivated.

Alarm setting in % Alarm, H/L: Indicates the desired alarm level. It is given in % of max measurement range.

Alarm delay in sec Delay – alarm: The delay from when the liquid level falls/rises to under/over the selected alarm, indicated in seconds.

Offset max/min level in mm. here you can adjust for a sensor smaller than the vessel at max level and min level

Select mechanical type: select the type of sensor you have

Refrigerant: Indicates the type of refrigerant the sensor shall measure on.

Measurement length in mm Measurement in mm: Indicates the length of the sensor in mm typically printed on the electrical part

Advanced settings

Here you make the advanced settings of the sensor

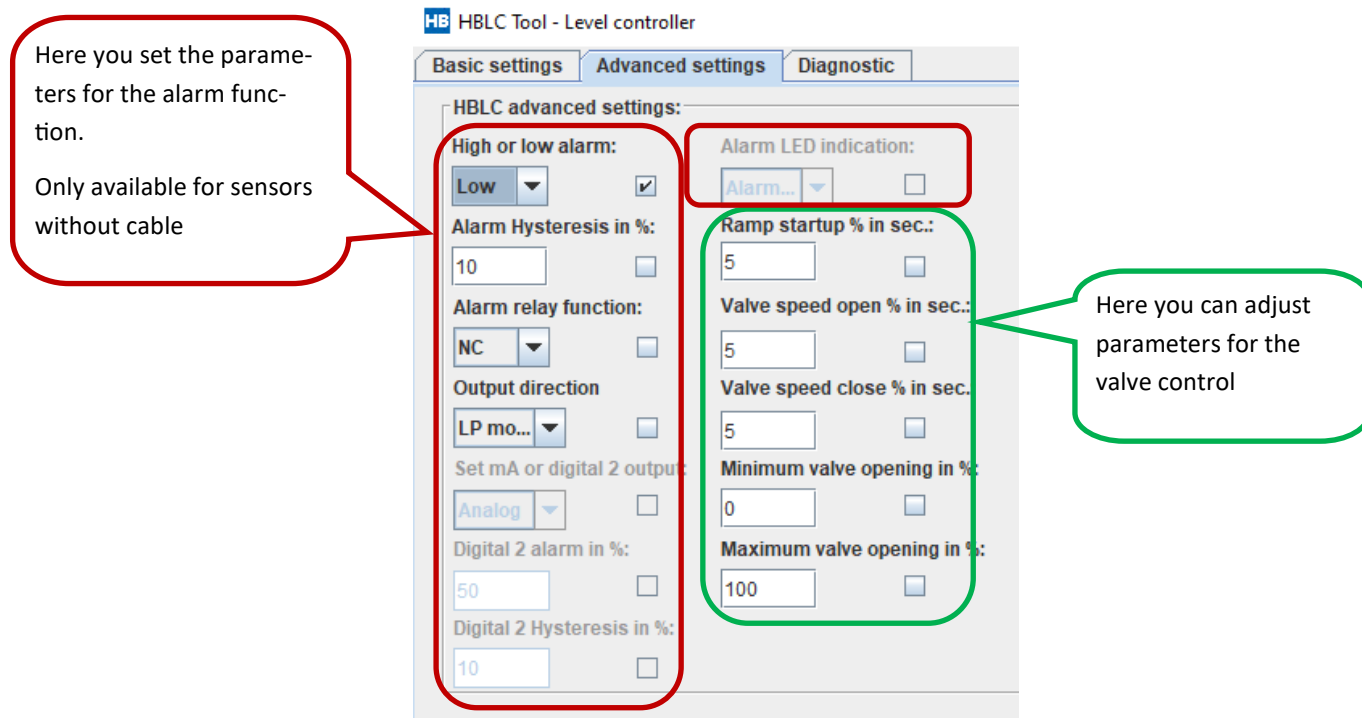

Alarm relay function: Here, the relay function is indicated, depending upon the instructions – NO or NC (normally open/normally closed). Here the signal can be changed from alarm on below or above the alarm setpoint

Output direction: Here you select either LP-mode (low pressure control) or HP-mode (high pressure control). In LP-mode, the container is filled so that the level is maintained, and in HP-mode the container is emptied so that the level is maintained. LP-mode = 4-20 mA. HP-mode = 20-4 mA.

Set mA or digital 2 output Select the sensor output digital or analog

Digital 2 alarm in %: set the alarm setpoint

Digital Hysteresis in %: Indicates the deviation required before the alarm is deactivated, following activation of the alarm. Alarm hysteresis in percent of the probes calibrated span 0 and 100%.

Alarm setting is as well in % of the probes calibrated span 0 and 100%.

E.g. alarm setting = 80%, Alarm hysteresis = 25%

Set LED indication: Determines the function LED lighting has.

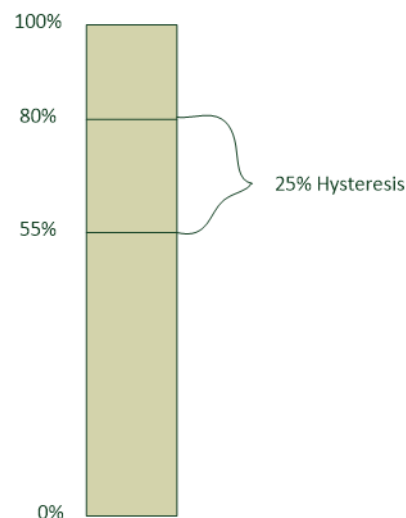

Diagnostic (calibration of sensor)

Here you make the calibration of the sensor. If the sensor is operating in one of the predefined liquid it is delivered with a calibration and does normally not need further calibration. If you need higher accuracy the sensor can be calibrated

The screenshot shows the 'Diagnostic' tab of the 'HBLT-Wire Tool - Level sensor' interface. It features several calibration fields and control elements:

- Zero calibration in pF:** A field showing the value 32.7 pF. A red callout explains that this value is normally calculated based on an automatic calibration and should not be changed.
- SPAN calibration in pF:** A field showing the value 123.4 pF. A green callout explains that this value is normally calculated based on an automatic calibration and should not be changed.
- Actual measurement in pF:** A field showing the value 32.6 pF. A blue callout indicates that this is the actual measurement value.
- Control and Level visualization:** A yellow callout points to a section showing 'Control' at 0% and 'Level' at 0%, with corresponding 4mA and 20mA scale indicators.
- Calibration Buttons:**
 - A 'Zero calibration' button is highlighted with a black callout stating: 'Use this button to make the zero calibration'.
 - A 'Calibrate known level' button is next to a field containing '100 %'. A black callout explains: 'Use the button and the field to make a calibration to a known level between 1 and 100%'.
- Enable Zero and Span configuration:** A checkbox is present at the bottom of the interface.

LED indication

- Green LED indicates 24 V DC supply; it flashes during operation. If "run-in" is not used, this function must be deactivated in the tool.
- Yellow LED indicates control.
The flashing sequence indicates if the valve is closing or opening.
- Red LED indicates high- or low-level alarm, depending upon the set-up.



3-digit display: (not available on /S stepper motor control version.)

Showing 0...100 % linearly corresponding to 4...20 mA.

LED Signal	ON/OFF/Frequency	Functionality
Green	ON	Supply voltage connected
	Flash	Run In start signal / in operation.
	OFF	No supply voltage
Yellow	ON	Activation of valve control / and during calibration
	OFF	Valve control not active
Red	ON	Alarm, high or low level, depending upon the setup.
	Flash slow	No contact to sensor probe or sensor probe shorted
	Flash fast	USB cable connected and communication active
	OFF	No alarm
Yellow + Red	Flash	Insufficient Power supply
All	Flash	USB cable connected and communication active
	OFF	No alarm

Calibration on the sensor

Calibration instructions:

0% or 100% for calibration **can be carried out independent of each other**. We recommend only calibrating at 0% if a high degree of accuracy is desired.

Note: To use this function the "Zero & span cal. Function " field found under basic settings have to be on - default is off

Instruction for 0% calibration:

- Connect the supply cable
- Empty the vessel
- Activate "R" for 5 seconds to activate calibration mode = Yellow LED is on (ON) during the 5 second activation and turns off (OFF) when calibration mode is activated.
- Activate "R" once = Yellow LED flash once. Afterwards, the green LED flashes to confirm calibration.

Instruction for 100% calibration:

- Fill the vessel to 100%.
- Activate "R" for 5 seconds to activate calibration mode = Yellow LED is on (ON) during the 5 second activation and turns off (OFF) when calibration mode is activated.
- Follow the instructions under "Configurations Instructions" regarding the installation of drivers in the program.
- Activate "R" twice = Yellow LED flashes twice. Afterwards, the green LED flashes to confirm calibration.

Fault detection

General: In case of fault, it is normally enough to replace the electronic part.

Fault	Reason	Correction of fault
No LED is on / not operating.	No supply to the sensor or defective cable/plug	Check and find faults in the power supply, or replace the supply cable.
Yellow and red LED flash.	Power supply is not sufficient.	Install proper power supply.
Valve open and close to fast.	Refrigerant is boiling in the stand-pipe	Increase "filter" settings and eventually increase P-band as well.
No contact activation	There may be dirt between the electronic housing and the mechanical housing.	Separate the two parts and clean the spring tip. Remember to apply silicone grease to the spring tip so as to avoid problems with moisture
Delay in sensor activation	May be caused by gas and bubbles in the system.	Check if the sensor is placed optimally so that gas is avoided.
The valve is not performing the control function well enough.	Oil has accumulated in the level indicator glass which cannot escape.	Drain the level indicator of oil and, if necessary, clean the oil from the rod.
There is no alignment between the output signal and the level in the level indicator.	The sensor is incorrectly calibrated.	Perform calibration.



NOTE! Fault detection and/or changing the electronic function can be carried out without releasing pressure from the system or disassembling the mechanical part of the sensor.

Sensor Repair

In case of faults with the sensor, it will typically only be necessary to replace the electronics.

Please contact your local distributor about how to handle complaints.

Further Information

For further information, please visit our website, www.hbproducts.dk, or send an email to: support@hbproducts.dk.

HB Products A/S – Bøgekildevej 21 – DK8361 Hasselager – support@hbproducts.dk – www.hbproducts.dk

Quick guide

Installation

The sensor is installed in the vessel using liquid sealant or PTFE tape like shown in the manual and the electrical unit is connected. If the electronic unit has the threaded union, make sure it is firmly tightened to secure good electrical connection.

Setup

The sensor is delivered pre-calibrated for the liquid you specified when ordering and ready for use. To obtain a more accurate measurement you need to calibrate the sensor as described in the complete manual. You need a computer and a USB/M12 cable to do the calibration and more advanced setup. The setup is done in the HB-tool which is downloaded from the HBproduct web page www.hbproducts.dk

Measurement signal

The sensor output is a 4-20mA provided on pin 4 in the M12 plug. The signal grow linear to the level. More advanced wiring and wiring of sensors controlling a valve is described in the complete manual.

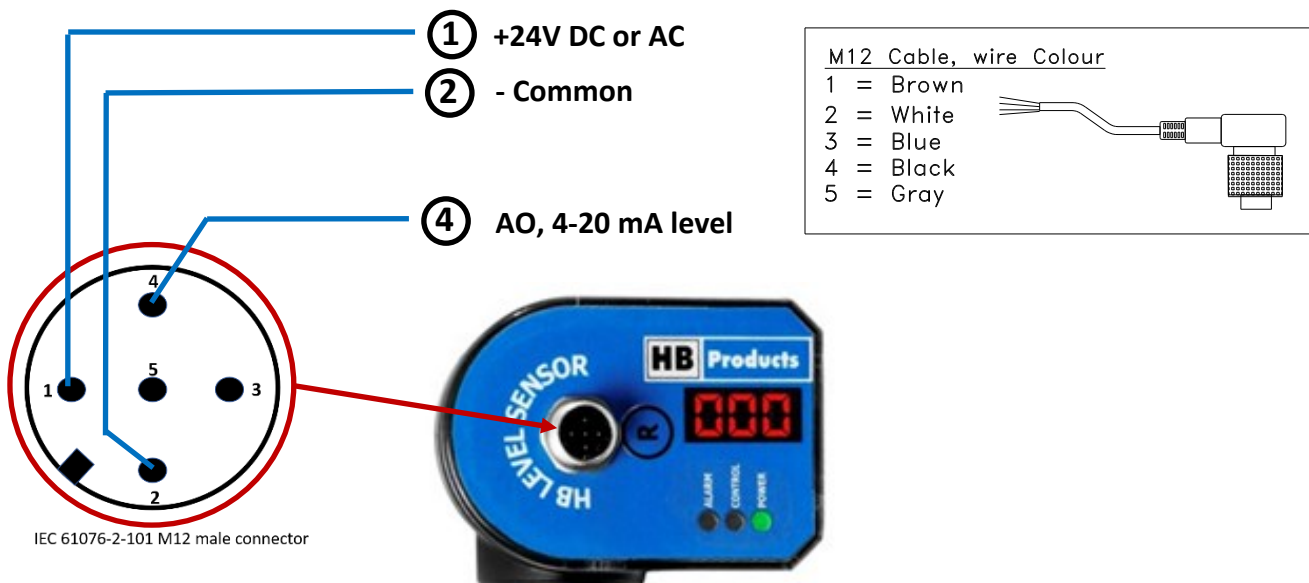

LED indication

When the sensor is operating the green LED should be on or flashing

LED Signal	ON/OFF/Frequency	Functionality
Green	ON	Supply voltage connected
	Flash	Run In start signal / in operation.
	OFF	No supply voltage