

Data sheet

Desuperheating valve

Type TEAT



Refrigerant injection into the suction line

TEAT valves are used to inject refrigerant into the suction line of the refrigeration system to reduce the high discharge temperatures that can occur when the system operates with highly superheated suction vapour.

This applies when, for example:

- a compressor runs either with low suction pressure or with high condensing temperature.
- a compressor runs with both low suction pressure and high condensing temperature. This applies especially to systems with R 22.
- a compressor receives highly superheated suction vapour.
- a compressor runs with capacity regulation by hot gas bypass.

Two-stage refrigeration plant

TEAT valves are also used in two-stage refrigeration plant to control liquid injection into the intercooler. The bulb is installed on the discharge line from the high-pressure compressor. The theoretically obtainable discharge temperature for given operating conditions can be found in the h, log p diagram for the refrigerant concerned.

Temperature regulation of the medium

TEAT valves have a further application: the temperature regulation of the medium, e.g. the temperature of the oil in a screw compressor.

Materials

Valve housing made of GGG40.3

Gaskets are non asbestos.

Technical data

- Refrigerants
Applicable to HCFC, non flammable HFC and R717 (Ammonia).
- Regulation ranges
See ordering table.
- P band
20°C
- Capillary tube length
5 m
- Max. bulb temperature
150°C

- Max. working pressure
PS = 20 bar
- Max. test pressure
p' = 30 bar
- Classification: DNV, CRN, BV, EAC etc.
To get an updated list of certification on the products please contact your local Danfoss Sales Company.

Identification

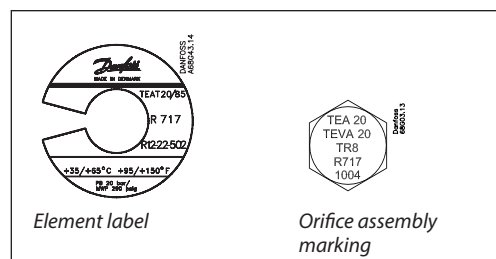

The thermostatic element

has a label giving valve type, temperature range and max. test pressure.

The orifice assembly

is common to TEAT, TEA and TEVA. The rated capacity, e.g. 8 TR (= 28 kW) for the refrigerant ammonia is given on the orifice assembly.

The orifice assembly can be used for both ammonia and fluorinated refrigerants.

Ordering TEAT

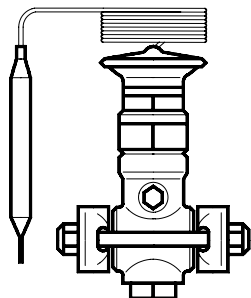

Type and rated capacity (TR)	Regulating range °C	Flange connection	Code no.		
			Assembled valve	Separate orifice assembly	Separate thermostatic element
TEAT 20-1	35 - 65	1/2 x 1/2	1)	068G2050	068G3262
	55 - 95	1/2 x 1/2	1)	068G2050	068G3260
	90 - 130	1/2 x 1/2	1)	068G2050	068G3261
TEAT 20-2	35 - 65	1/2 x 1/2	068G6125	068G2051	068G3262
	55 - 95	1/2 x 1/2	068G6062	068G2051	068G3260
	90 - 130	1/2 x 1/2	068G6065	068G2051	068G3261
TEAT 20-3	35 - 65	1/2 x 1/2	1)	068G2052	068G3262
	55 - 95	1/2 x 1/2	1)	068G2052	068G3260
	90 - 130	1/2 x 1/2	1)	068G2052	068G3261
TEAT 20-5	35 - 65	1/2 x 1/2	068G6126	068G2053	068G3262
	55 - 95	1/2 x 1/2	068G6061	068G2053	068G3260
	90 - 130	1/2 x 1/2	068G6127	068G2053	068G3261
TEAT 20-8	35 - 65	1/2 x 1/2	068G6128	068G2054	068G3262
	55 - 95	1/2 x 1/2	068G6063	068G2054	068G3260
	90 - 130	1/2 x 1/2	068G6066	068G2054	068G3261
TEAT 20-12	35 - 65	1/2 x 1/2	1)	068G2055	068G3262
	55 - 95	1/2 x 1/2	1)	068G2055	068G3260
	90 - 130	1/2 x 1/2	1)	068G2055	068G3261
TEAT 20-20	35 - 65	1/2 x 1/2	068G6068	068G2056	068G3262
	55 - 95	1/2 x 1/2	068G6064	068G2056	068G3260
	90 - 130	1/2 x 1/2	068G6067	068G2056	068G3261
TEAT 85-33	35 - 65	3/4 x 3/4	068G6129	068G2057	068G3262
	55 - 95	3/4 x 3/4	068G6070	068G2057	068G3260
	90 - 130	3/4 x 3/4	068G6072	068G2057	068G3261
TEAT 85-55	35 - 65	3/4 x 3/4	068G6130	068G2058	068G3262
	55 - 95	3/4 x 3/4	068G6073	068G2058	068G3260
	90 - 130	3/4 x 3/4	068G6131	068G2058	068G3261
TEAT 85-85	35 - 65	3/4 x 3/4	068G6069	068G2059	068G3262
	55 - 95	3/4 x 3/4	068G6071	068G2059	068G3260
	90 - 130	3/4 x 3/4	068G6132	068G2059	068G3261

1) This valve size must be ordered as a complete valve + a separate orifice assemble in the required size.
 Example: TEAT 20-3 must be ordered as **068G6125 + 068G2052**.
 The orifice in the complete TEAT 20-2 valve must then be changed with the separate orifice assemble.

Separate filter with gaskets, staybolts and nuts for TEAT 20, code no. **006-0042** for TEAT 85, code no. **006-0048**.

Stainless steel bulb pocket, gasket, and union nut, code no. **993N3615**, for screwing into G 1/2 socket welded to tube or tank.

Rated capacity in kW

Type and rated capacity (TR)	Rated capacity in kW ¹⁾ at Δp = 8 bar					
	R717 (NH ₃)	R22	R134a	R404A	R12	R502
TEAT 20-1	3.3	0.8	0.7	0.6	0.5	0.6
TEAT 20-2	6.4	1.5	1.2	1.1	0.9	1.1
TEAT 20-3	9.7	2.3	1.7	1.6	1.3	1.6
TEAT 20-5	16.0	3.6	3.0	2.9	2.3	2.7
TEAT 20-8	25.6	6.2	4.6	4.4	3.5	4.4
TEAT 20-12	38.4	9.2	6.9	6.7	5.3	6.5
TEAT 20-20	64.0	15.4	13.1	12.6	10.0	10.8
TEAT 85-33	106	26	19.5	18.8	14.9	18.0
TEAT 85-55	173	42.4	31.8	30.6	24.3	27.4
TEAT 85-85	274	66.3	50.3	48.4	38.4	46.5

1) Rated capacity is valve capacity at +5°C evaporating temperature, and 4K subcooling of the liquid in front of the valve.

2) Note: Subcooling of the liquid in front of the valve is essential for the function of the valve. Lack of subcooling will lead to malfunction of the valve and increased wear on orifice.

Extended capacities in kW

R717 ¹⁾

R22 ¹⁾

Valve size	Pressure drop across valve Δp bar				
	4	6	8	11	15
20 - 1	2.3	2.8	3.3	3.6	4.7
20 - 2	4.8	5.7	6.4	7.2	7.9
20 - 3	7.2	8.5	9.7	10.8	11.7
20 - 5	12.1	14.2	16.0	18.0	19.8
20 - 8	18.6	22.1	25.6	28.5	31.4
20 - 12	29.1	33.7	38.4	43.0	47.1
20 - 20	47.7	57.0	64.0	72.1	79.1
85 - 33	80.2	94.2	106.4	118.6	130.3
85 - 55	136.1	157.0	176.8	197.7	215.2
85 - 85	203.5	239.6	274.5	302.4	334.9

Valve size	Pressure drop across valve Δp bar				
	4	6	8	11	15
20 - 1	0.6	0.7	0.8	0.9	1.0
20 - 2	1.2	1.4	1.5	1.7	1.9
20 - 3	1.7	2.0	2.3	2.6	2.9
20 - 5	2.7	3.1	3.6	4.0	4.8
70 - 8	4.4	5.2	6.2	6.9	7.6
20 - 12	7.0	8.1	9.2	10.4	11.3
20 - 20	11.5	13.7	15.4	17.2	18.8
85 - 33	19.3	22.4	25.6	28.5	31.4
85 - 55	32.6	37.8	42.4	47.7	52.3
85 - 85	48.8	58.2	66.3	72.1	81.4

¹⁾ The rated capacity is valve capacity at +5°C evaporating temperature, +32°C condensing temperature and 4K subcooling of the liquid in front of the valve.

Design/
Function

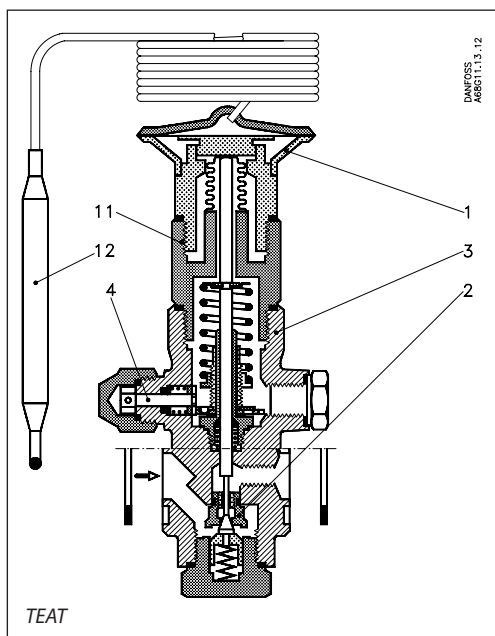

- 1. Thermostatic element (diaphragm)
- 2. Orifice assembly
- 3. Valve body
- 4. Setting spindle
- 11. Intermediate section
- 12. Bulb

Temperature variations in the discharge pipe where the bulb is placed act on the thermal charge in the bulb (12). This changes the pressure in the thermostatic element (1) and thus gives modulating liquid injection.

If leakage in the thermostatic element does occur, it will not result in refrigerant loss.

The thermostatic element is screwed to the intermediate section (11) of the valve. A bellow on the intermediate section means that the suction pressure cannot influence the valve setting.

The movement of the setting spindle (4) is transferred through a gearwheel mechanism.

The orifice assembly (2) is identical to that of TEA thermostatic expansion valves.

Note: The TEAT is not able to close completely tight, so a solenoid valve is needed to shut off liquid supply, when the system stops.

Dimensions and weights

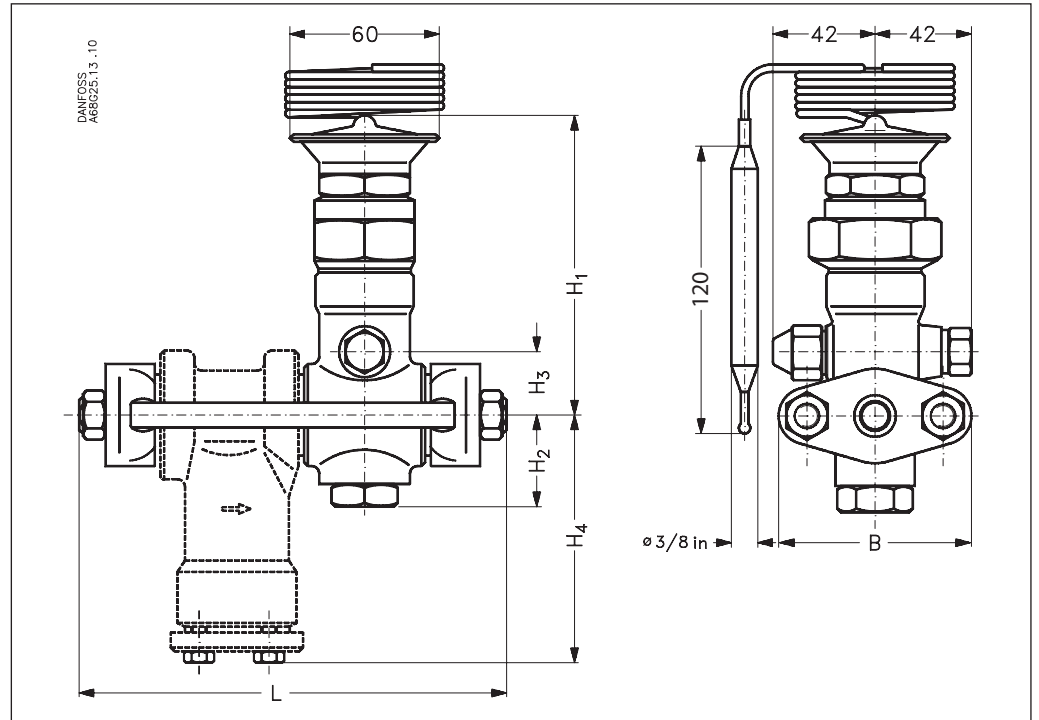

Type	H ₁ mm	H ₂ mm	H ₃ mm	H ₄ mm	L		B mm	Weight	
					Excl. strainer mm	Incl. strainer mm		Excl. strainer kg	Incl. strainer kg
TEAT 20	121.5	37	25	96	110	164	80	2.1	3.0
TEAT 85	131.5	37	35	106	125	199	95	3.0	4.5

Danfoss can accept no responsibility for possible errors in catalogues, brochures and other printed material. Danfoss reserves the right to alter its products without notice. This also applies to products already on order provided that such alterations can be made without consequential changes being necessary in specifications already agreed. All trademarks in this material are property of the respective companies. Danfoss and the Danfoss logo are trademarks of Danfoss A/S. All rights reserved.