

Single Point Level Switch: SPS

Specifications, Applications,
Service Instructions & Parts

Single Point
Level Sensors & Switches
for refrigerants

for Refrigerant Vessels,
Compressor Packages,
Pump Packages, and
Flooded Evaporators

ISO 9002

INTRODUCTION

These compact single point level sensors and switches are economical solutions for reliable and accurate level detection. They are designed to detect the presence of liquid (but not oil) at a specific location in vessels containing refrigerant. The computer-compatible, low-voltage signal output of the level sensor can be used directly with plant computers, PLCs, solid-state relays or other controllers. The relay output from the level switch is suitable for direct connection to solenoids, alarms, and computers.

KEY FEATURES

- No moving parts in the probe
- Low refrigerant temperatures possible
- Plug-in electronics
- Suitable for ammonia, R22, R134a, R404A, R507, and other Hansen approved refrigerants
- Unaffected by normal splashing or oil coating
- Reliable, non-optic
- Stainless steel probe body

ADVANTAGES

More compact than mechanical float devices, these level devices are very reliable, even in low-temperature systems. Unlike optic devices, they are not affected by film buildup or oil scum. Also, there is no lens to be fooled by frost buildup. They come factory precalibrated and tested; ready to use. There are no moving parts in the probe to break, jam, or fail. Electronics can be easily replaced without pumping out (opening) the system.

APPLICATIONS

These level sensors and switches are designed specifically for use in refrigeration systems. They provide single point refrigerant liquid level detection for receiver/vessels, intercoolers, control pressure receivers, packaged chillers, compressor packages, pump packages, and flooded evaporators. In many cases, Hansen single point level sensors and switches can be used in place of float switches, such as for high or low level alarms in conjunction with plant computers, PLCs, or shut-off solenoid valves.

TYPICAL APPLICATIONS

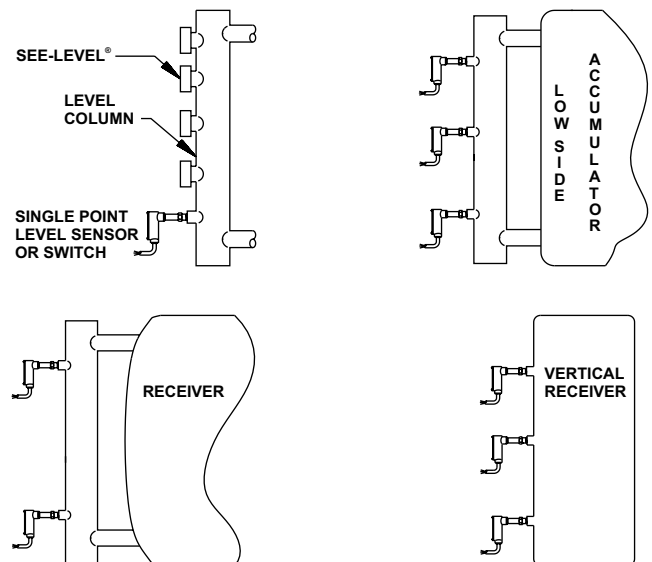

These illustrations are representations only and should not be used for actual construction purposes.

MATERIAL SPECIFICATIONS

ELECTRICAL—SINGLE POINT LEVEL SENSOR

Signal Output: NPN (Current Sinking),
Normally Closed

Supply Voltage: 10 to 30 volt DC

Power Consumption: 4 VA

Maximum Load: 300 ohms (80 mA @ 24V)

Housing: Raintight NEMA 3R, Aluminum

Ambient Temperature: -20°F to +125°F (-30°C to +50°C)

Sensing Principle: Capacitance

ELECTRICAL—SINGLE POINT LEVEL SWITCH

Signal Output: Single Pole, Double Throw (SPDT)

Supply Voltage: 115V or 230V, 50/60 Hz

Relay Rating: 10 amps @ 115 VAC, 5.0 amps @ 230 VAC,
10 amps @ 30 VDC

Housing: Raintight NEMA 3R, Aluminum

Ambient Temperature: -20°F to +125°F (-30°C to +50°C)

Sensing Principle: Capacitance

MECHANICAL

Connection: 1/2" NPT

Probe: Stainless steel, ASTM A582

Safe Working Pressure: 400 psig (27 bar)

Refrigerant Temperature: -60°F to +150°F (-50°C to +65°C)

OPTIONAL ADAPTER KIT

An optional adapter kit is available to retrofit existing sight glasses with the SPL or SPS. This allows direct connection to Hansen SEE-LEVEL®, Phillips Level Eye®, and Henry liquid indicators. The adapter with gaskets and adapter ring is installed in place of the sight glass lens and retainer ring. The SPL or SPS is then screwed into the adapter. This option allows easy retrofitting without the need to add on additional fittings to the level column or vessel. Order Adapter Kit number 77-1009 for use with Hansen SEE-LEVEL® and Phillips Level Eye® or Adapter Kit number 77-1010 for use with Henry Liquid Indicators.

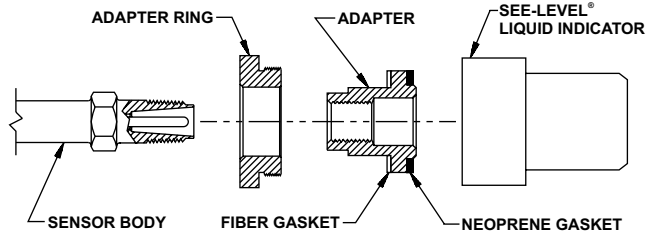

SELECTION

TYPE	FOR USE WITH	INPUT POWER	OUTPUT
SPL (SENSOR)	Computers Solid-State Relays PLC	10 to 30 VDC	NPN (80 mA @ 24V)
SPS (SWITCH)	Solenoid Valves Motor Relays Alarms Computers	115 VAC or 230 VAC	SPDT Relay (10 Amp @ 115V or 5 Amp @ 230 V)

Note:

SPDT is Single Pole, Double Throw.

NPN is a current sinking transistor switched output.

INSTALLATION

These devices must be installed with the probe horizontal. Handle with care; dropping can damage the probe. Vessel should be free of refrigerant and the system must be evacuated to zero pressure before installation begins. Level columns should be at least 3" diameter for low-temperature accumulators.

Use proper thread sealant and screw the threaded end of the probe body into the half coupling located on the vessel or column. Loosen sealing locknut to rotate the housing to suit the application, and then retighten the locknut. Make sure that locknut is tight to prevent moisture from entering the device. After wiring, use a sealant (e.g. silicone) in the conduit connection to prevent migration and condensation of water vapor inside housing.

INSTALLATION DIMENSIONS

SPL: Single Point Level Sensor

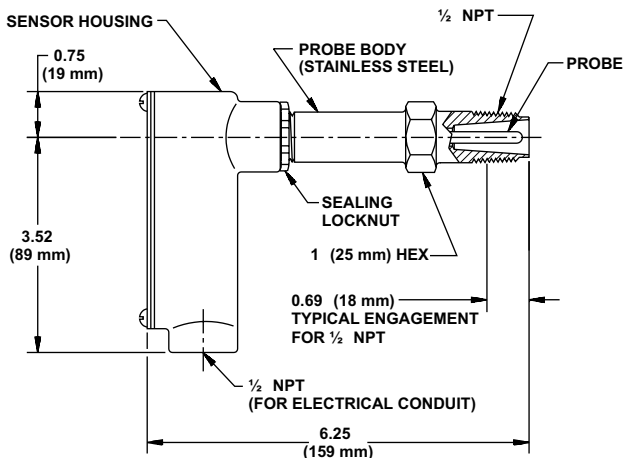

SPS: Single Point Level Switch

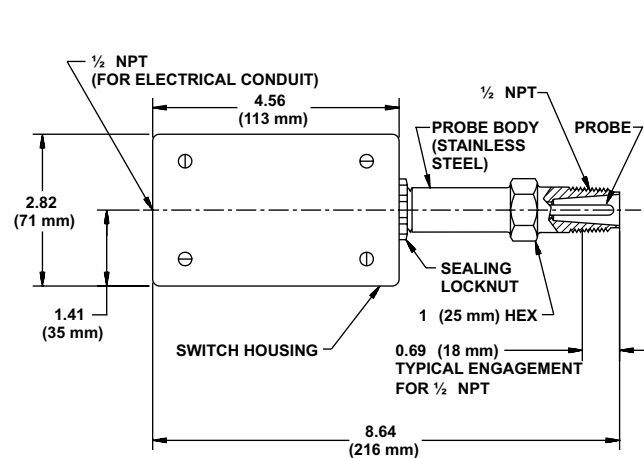

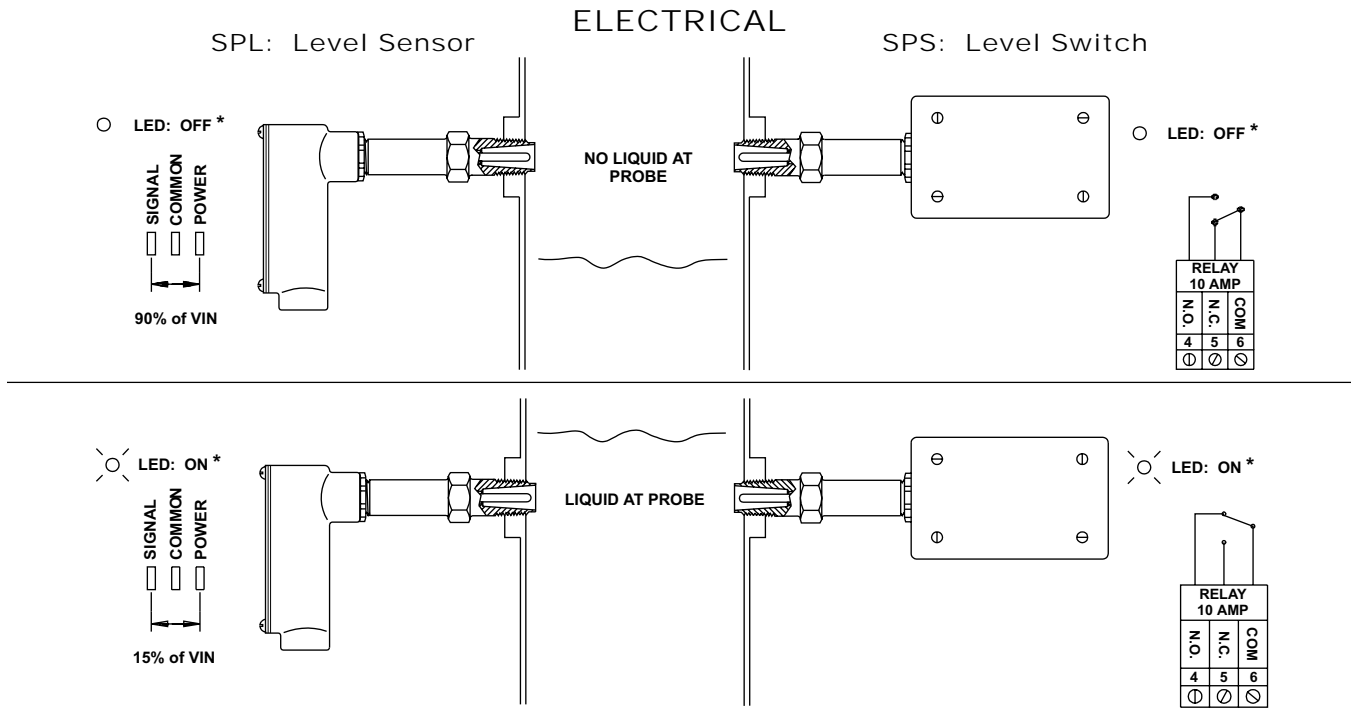

VIN = Supply Voltage Input

*Box cover must be removed to view the calibration LED.

The above diagram illustrates the level sensor (SPL) voltage output and the position of the level switch relay (SPS) with and without liquid at the probe. There is a built-in anti-splash time delay (3 seconds) which should prevent most short cycling. However, if a greater differential is desired, it can be simulated by utilizing an auxiliary time delay relay or a delay circuit.

SINGLE POINT LEVEL SENSOR—SPL

The NPN level sensors are low-voltage, three-wire devices which have NPN (current sinking) output; see the Typical Wiring below. The control loop wire size should be at least 20 AWG (0.5 mm²) and limited to 100 ft. (30 m). For best electrical noise protection, use shielded cable, and do not run control loop wiring with or near power wiring.

A small, bright LED inside sensor housing illuminates to indicate the presence of liquid. With liquid at probe, the output signal will be 15% of the voltage supply (LED on). In the absence of liquid at probe, the output signal will be 90% of the voltage supply (LED off).

TYPICAL WIRING—SPL

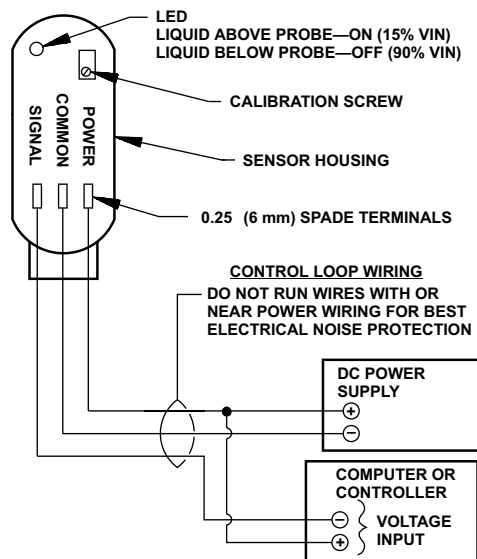

SINGLE POINT LEVEL SWITCH—SPS

The single point level switches are an SPDT relay device that can be wired either normally closed or normally open. When there is no liquid at the probe (or the power is off), the N.C. and COM terminals are closed (terminals 5 and 6) and the LED is off. When there is liquid at the probe, the N.O. and COM terminals are closed (terminals 4 and 6) and the LED is on. A maximum wire size of 12 AWG can be used with the wire terminals.

TYPICAL WIRING—SPS

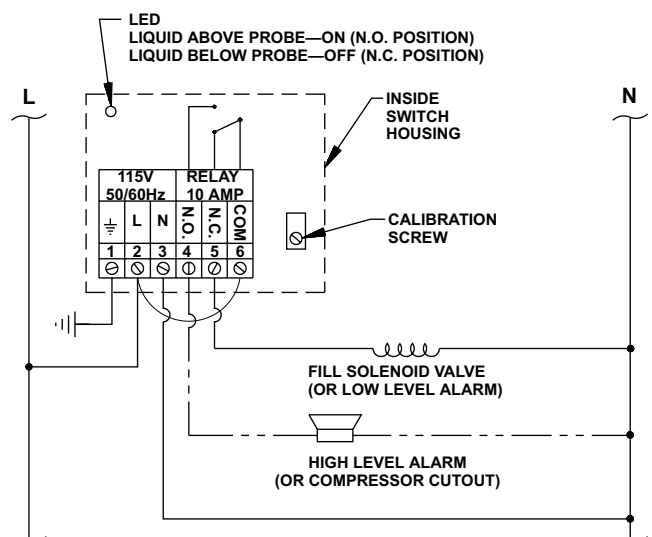

TROUBLESHOOTING

DOES NOT INDICATE LEVEL CHANGES	
CAUSE	ACTION
A. Moisture in the housing or housing-to-probe body joint. B. Fault in the wiring. C. No power to the housing or wrong voltage. D. Calibration not correct. E. Oil level is above the probe.	A. See Note 1 below. B. See Note 2 below. C. Check voltage at the terminals in the housing. D. See recalibration instructions below. E. Remove excess oil or use "oil-sensor."
OCCASIONAL ERRATIC OUTPUT	
CAUSE	ACTION
A. Moisture in the housing or housing-to-probe body joint. B. Rapid suction pressure pull down results in bubbling and surging liquid. C. High-voltage power wires near control loop wiring. D. Non-isolated devices (sensors or others) on the same power supply as sensor. (SPL only)	A. See Note 1 below. B. Alter compressor loading sequence, defrost sequence, or liquid make-up feed time to "reduce" pressure fluctuations in the vessel. C. Relocate the control loop wiring away from the power wiring. D. Place the sensor on separate power supply or replace non-isolated devices with isolated ones.

Note 1:
MOISTURE IN HOUSING. Dry out the housing. If appearance is dry, look for signs of moisture damage, such as white residue. Check cover gaskets, watertight cable connectors, and other water sealing joints. Replace if worn. If a conduit connection is used, carefully seal the inside to prevent moisture migration and condensation into the housing. Conduit should enter housing from below.

Note 2:
FAULT IN THE WIRING. Check the wires in the housing for proper connection. See page 3 for wiring diagrams. Wires should be securely fastened and not frayed. Also check for continuity in the wires.

RECALIBRATION INSTRUCTIONS

These level sensors and switches are accurately factory precalibrated for vessels of any diameter containing refrigerant. They are ready-to-use and should not require any field adjustment in calibration settings whatsoever. However, in the event that a level sensor or switch should need recalibration, follow the instructions below.

Before recalibration begins, the liquid in vessel or column must be clearly below the level point of the probe. Remove the housing cover. Turn calibration screw clockwise until the small LED illuminates. Then, slowly turn calibration screw counterclockwise just until the LED turns off. Then continue to turn calibration screw 2 additional full turns counterclockwise (to compensate for tolerances). It should now be recalibrated. If the SPL or SPS cannot be satisfactorily calibrated, contact factory.

CAUTION

These level sensors and switches are designed for refrigeration systems. Read these instructions and related safety precautions before selecting, using, or servicing these devices. Only knowledgeable, trained refrigeration mechanics should install, operate, or service these devices. Stated temperature and pressure limits should not be exceeded. Do not remove these devices from vessels unless the system has been evacuated to zero pressure. Escaping refrigerant may cause injury, particularly to the eyes and lungs.

WARNING: As with all electronic and mechanical components, there is a limited life expectancy. An expected life of seven to ten years is typical. This should be understood as only a suggested replacement time period. Actual ambient conditions, contaminants, quality of electric current, voltage, etc., may necessitate a different replacement schedule. Regardless, level sensor and switches should be inspected at least annually to ensure their safe and continuous service. See also Safety Precautions in the current List Price Bulletin and the Safety Precautions Sheet supplied with the product.

WARRANTY

Hansen electronics are guaranteed against defective materials or workmanship for 90 days F.O.B. factory. All other components are guaranteed for one year F.O.B. factory. No consequential damages or field labor is included.

ORDERING INFORMATION

Cat. No.		Description
ammonia	halocarbons	
SPLN	SPLF	Single Point Level Sensor, Current Sinking NPN Output
SPSN	SPSF	Single Point Level Switch, SPDT Relay

TO ORDER: Specify catalog number, refrigerant, and voltage (115V or 230V, SPS only).

Other Liquids: The SPLN and SPSN are also suitable for water up to +125°F (+50°C), Contact Factory. Consult Hansen for sensors and switches to detect the level of refrigeration oil.

HANSEN TECHNOLOGIES CORPORATION

6827 High Grove Boulevard
 Burr Ridge, Illinois 60521 USA
 Telephone: 630-325-1565
 Toll-free: 800-426-7368
 Fax: 630-325-1572
 E-mail: info@hantech.com
 Web site: www.hantech.com