



1 1/4" RT125H Globe Hand Expansion Valve

Specifications, Applications, Service Instructions & Parts

HAND EXPANSION VALVES (REGULATORS)

Threaded 3/8" through 1-1/4"
(10mm through 32mm)
Welding 1/2" through 4"
(13mm through 100mm)
Globe or Angle for refrigerants



INTRODUCTION

These precision-calibrated, adjustable, slotted plug flow regulating valves (hand expansion valves) are ideal for metering or flashing expansion of liquid refrigerants. Their slotted plugs are more tolerant of dirt particles than are common metal-seated tapered-plug expansion valves, and are less susceptible to wire drawing. Valves 2 1/2" (65 mm) and larger have a characterized plug. All valves have near linear flow characteristics per turn open and are tight closing with Teflon seats. These valves have stainless steel stems with back seating for seal replacement. The patented non-leak seal plus packing design permits low torque operation for valve adjustments since the packing nut requires little tightening. Bar handle or yellow seal caps distinguish them from shut-off valves. Suitable for ammonia or halocarbons.

APPLICATIONS

- Liquid feed or circulating liquid overfeed evaporators
- High pressure or intermediate pressure liquid feed to accumulators, intercoolers, or recirculators
- Defrost condensate relief
- Hot gas feed to evaporators
- Equalize evaporator to suction pressure after defrost

KEY FEATURES

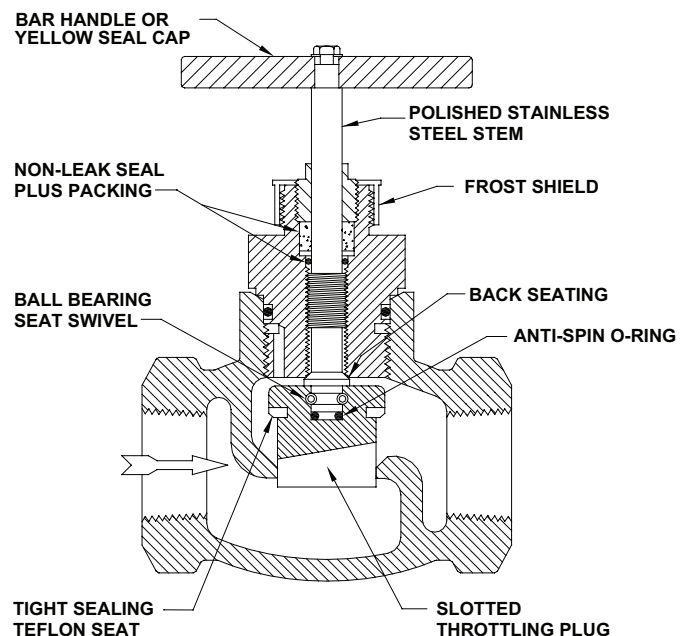

CAPACITIES, TONS (kW)

REFRIGERANT & APPLICATION		NOMINAL SIZE inch (mm)																			
		3/8 (10)		1/2 (13)		3/4 (20)		1 (25)		1-1/4 (32)		1-1/2 (40)		2 (50)		2-1/2 (65)		3 (80)		4 (100)	
		min	max	min	max	min	max	min	max	min	max	min	max	min	max	min	max	min	max	min	max
R717	Circulating 4:1	1.5 (6.3)	12 (42)	1.5 (6.3)	17 (63)	1.5 (6.3)	37 (130)	1.5 (6.3)	62 (220)	1.5 (6.3)	110 (390)	9.2 (31)	150 (530)	18 (63)	290 (1000)	66 (230)	410 (1400)	99 (350)	630 (2200)	150 (540)	1100 (3900)
	Liquid Makeup	7.4 (30)	36 (130)	7.4 (30)	60 (210)	7.4 (30)	110 (390)	7.4 (30)	180 (630)	7.4 (30)	330 (1200)	45 (150)	450 (1600)	89 (300)	860 (3000)	320 (1100)	1200 (4200)	480 (1700)	1900 (6700)	740 (2600)	3300 (12000)
R22	Circulating 2:1	0.7 (2.8)	5.6 (19)	0.7 (2.8)	7.7 (28)	0.7 (2.8)	18 (63)	0.7 (2.8)	29 (100)	0.7 (2.8)	52 (180)	4.2 (14)	72 (250)	8.4 (28)	140 (490)	30 (100)	200 (700)	46 (150)	300 (1100)	70 (240)	520 (1800)
	Liquid Makeup	1.6 (6.7)	7.4 (26)	1.6 (6.7)	12 (42)	1.6 (6.7)	23 (81)	1.6 (6.7)	38 (130)	1.6 (6.7)	68 (240)	9.8 (33)	93 (330)	20 (67)	180 (630)	71 (250)	250 (880)	110 (370)	390 (1400)	160 (580)	670 (2400)

Circulating capacities assume a 10 psi (0.7 bar) drop. See page 2 for more detailed information on conditions and sizing.

MATERIAL SPECIFICATIONS

Body:

Screwed Bonnet, 3/8"-1-1/4" (10mm-32mm): Cast ductile iron, ASTM A536

Bolted Bonnet, 1/2"-1-1/4" (13mm-32mm): Forged steel, ASTM A105; 1-1/2"-4" (40mm-100mm): Cast steel, ASTM A352 Grade LCB

Bonnet:

Screwed, 3/8"-1-1/4" (10mm-32mm): Zinc plated steel, ASTM A311 Grade 1018

Bolted, 1/2"-4" (13mm-100mm): Cast ductile iron, ASTM A536

Bonnet Seal:

Screwed, 3/8"-1-1/4" (10mm-32mm): Neoprene O-ring plus steel knife edge

Bolted, 1/2"-4" (13mm-100mm): Non-asbestos graphite composite

Stem: Polished stainless steel

Stem Packing: Graphite Composite plus neoprene O-ring in series

Packing Nut: Zinc plated steel

Throttling Plug, 3/8"-1-1/4" (10mm-32mm): Stainless steel; 1-1/2"-4" (40mm-100mm): Zinc plated steel

Seat Disc: Retained PTFE Teflon

Ball Bearings: Stainless steel

Bar Handle: Zinc plated steel

Seal Cap: Yellow, 3/8"-1-1/4" (10mm-32mm): Glass-filled polymer, Neoprene O-ring seal, safety vented; 1-1/2"-4" (40mm-100mm): Zinc plated steel, painted

Operating Temperature:

Standard, -60°F to 240°F (-51°C to 115°C), temperatures below -60°F (-51°C) to -76°F (-60°C) at coincident pressures (Bolted bonnet only)

Optional, -20°F to 300°F (-29°C to 149°C), contact factory (Bolted bonnet only)

Safe Working Pressure: 400 psig (28 bar g) standard, 600 psig (41 bar g) upon request (Bolted bonnet only)

Connection Dimensions: Threaded: 3/8"-1-1/4" match US NPT female tapered pipe thread; Welded 1/2"-1-1/2" Match Schedule 80 pipe; 2"-4" Match Schedule 40 pipe

VALVE SIZING AND SETTING

To properly size and set hand expansion valves, determine the refrigerant, estimated pressure drop through the valve (not the system), evaporator load in tons (kW) and the circulating rate, or desired capacity of liquid makeup in tons (kW). In general, the valve size selection should be based on the valve adjusted to 1/2 open. Select liquid line sizes so that velocity is limited to 7 ft/s (2.1 m/s) for ammonia, and 5 ft/s (1.5 m/s) for R22, to reduce the potential for liquid velocity shock (water hammer).

For Circulating Liquid Overfeed: The steps below determine the required flow coefficient, Cv (Kv), and required turns open. For sizing assistance, contact Hansen. The circulating capacities assume 0°F (-18°C) evaporator temperature liquid. For other evaporator temperatures these values will change only slightly due to density and latent heat variations.

1. Evaporator load, tons(kW) times the circulating rate = **equivalent load, tons (kW)** = _____.

2. **Tons/Cv (kW/Kv)** from table below = _____.

3. **Equivalent load, tons (kW)** divided by **tons/Cv (kW/Kv)** = **required flow coefficient Cv (Kv)** = _____.

4. Refer to Cv (Kv) Per Turns Open table.
Valve size and turns open = _____.

TONS/Cv (kW/kv) CIRCULATING LIQUID OVERFEED

REFRIG	TEMP	PRESSURE DROP (ΔP)*				
		5 psi (0.3 bar)	10 psi (0.7 bar)	15 psi (1.0 bar)	20 psi (1.4 bar)	30 psi (2.0 bar)
R717	0°F (-18°C)	43 (165)	61 (250)	75 (301)	86 (350)	106 (426)
R22	0°F (-18°C)	10 (39)	14 (55)	18 (70)	20 (80)	25 (100)

*Pressure drop across the hand expansion valve.

For Liquid Makeup: Maximum capacities are possible with appropriate line sizing. The valve should be sized for intermittent, float-switch-operated flow. For example, a valve open 50% of the time feeding a 100 ton (350 kW) accumulator should be sized for 200 tons (700 kW). When the required valve size is greater than 1 1/2" (40mm), two expansion valves and solenoid valves staged in parallel should be used to help reduce the potential of liquid velocity shock (water hammer).

To determine required flow coefficient, Cv (Kv), estimate the approximate capacity in tons (kW) of liquid makeup desired and divide by 74.2 tons per Cv (302 kW per Kv) for ammonia, 16.4 tons per Cv (66.7 kW per Kv) for R22. These ratings are based on 86°F (30°C) saturated liquid and 0°F (-18°C) evaporating temperature. Refer to the table Cv (Kv) Per Turns Open for the appropriate valve size and turns open. For other evaporator temperatures, the values will change only slightly.

Cv (Kv) PER TURNS OPEN

NOMINAL SIZE inch (mm)	TURNS OPEN								
	1	2	3	4	5	6	7	7.5	
SCREWED BONNET	3/8 (10)	0.1 (0.1)	0.2 (0.2)	0.4 (0.3)	0.6 (0.5)	0.8 (0.7)	-	-	-
	1/2 (13)	0.1 (0.1)	0.3 (0.3)	0.6 (0.5)	0.9 (0.8)	1.1 (1.0)	-	-	-
	3/4 (20)	0.1 (0.1)	0.8 (0.7)	1.5 (1.3)	2.2 (1.9)	2.9 (2.5)	-	-	-
	1 (25)	0.1 (0.1)	0.3 (0.3)	0.6 (0.5)	1.2 (1.0)	2.2 (1.9)	3.3 (2.9)	4.2 (3.6)	4.5 (3.9)
	1-1/4 (32)	0.1 (0.1)	0.3 (0.3)	0.9 (0.8)	2.0 (1.7)	4.0 (3.5)	5.8 (5.0)	7.0 (6.1)	7.4 (6.4)
BOLTED BONNET	1/2 (13)	0.1 (0.1)	0.2 (0.2)	0.3 (0.3)	0.4 (0.3)	0.6 (0.5)	0.8 (0.7)	0.9 (0.8)	1.1 (1.0)
	3/4 (20)	0.1 (0.1)	0.2 (0.2)	0.5 (0.4)	0.9 (0.8)	1.4 (1.2)	2.0 (1.7)	2.6 (2.2)	2.9 (2.5)
	1 (25)	0.1 (0.1)	0.3 (0.3)	0.6 (0.5)	1.2 (1.0)	2.2 (1.9)	3.3 (2.9)	4.2 (3.6)	4.5 (3.9)
	1-1/4 (32)	0.1 (0.1)	0.3 (0.3)	0.9 (0.8)	2.0 (1.7)	4.0 (3.5)	5.8 (5.0)	7.0 (6.1)	7.4 (6.4)
	1-1/2 (40)	0.6 (0.5)	1.5 (1.3)	4.5 (3.9)	7.0 (6.1)	10 (8.7)	14 (12)	15 (13)	-
	2 (50)	1.2 (1.0)	4.0 (3.5)	7.5 (6.5)	11 (9.5)	15 (13)	18 (16)	22 (19)	-
	2-1/2 (65)	4.3 (3.7)	8.7 (7.5)	15 (13)	22 (19)	28 (24)	35 (30)	43 (37)	-
	3 (80)	6.5 (5.6)	13 (11)	23 (20)	33 (29)	42 (36)	52 (45)	65 (56)	-
	4 (100)	10 (8.7)	20 (17)	35 (30)	50 (43)	65 (56)	80 (69)	100 (87)	-

INSTALLATION

Valves should be installed with the stem horizontal or upright. For liquid makeup, valves should be located within 2 ft (0.6 m) of the upstream solenoid valve. The available pressure drop should occur across the hand expansion valve, not through the solenoid valve. Proper pipe sizing is essential for optimal control.

SCREWED BONNET
3/8" to 1-1/4" (10 mm to 32 mm)

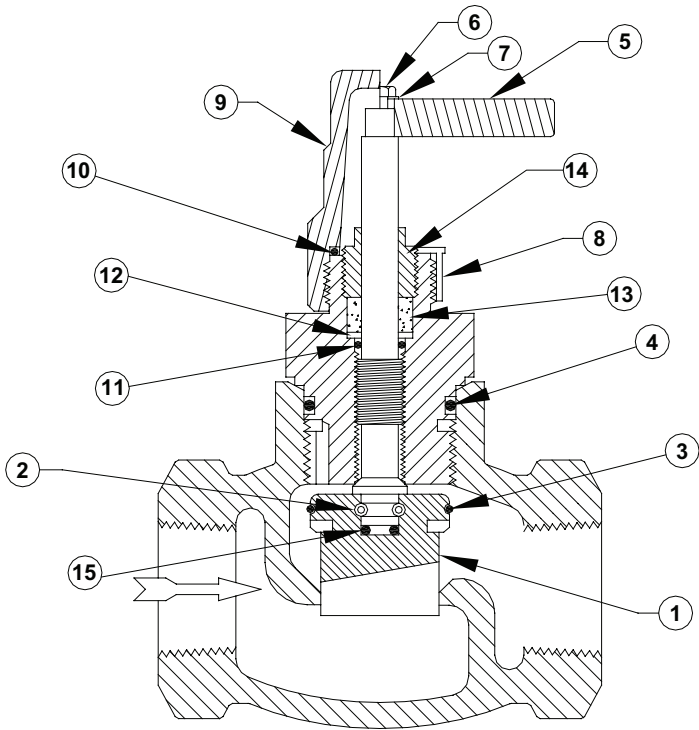

BOLTED BONNET
1/2" to 4" (13 mm to 100 mm)

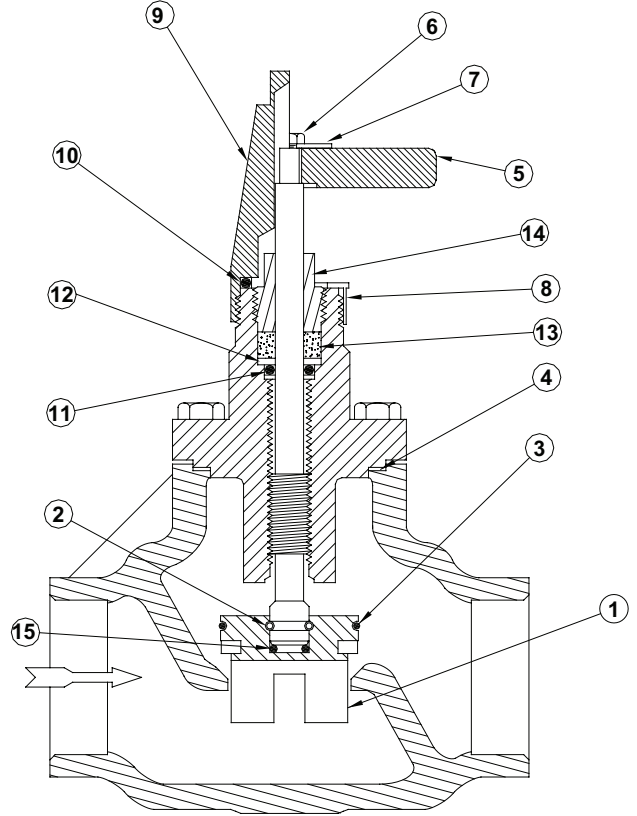

SCREWED BONNET 3/8"-1-1/4" (10mm-32mm)

DESCRIPTION	NOMINAL SIZE inch (mm)				
	3/8 (10)	1/2 (13)	3/4 (20)	1 (25)	1-1/4 (32)
Throttling Plug Kit	50-1060	50-1061	50-1062	50-1015	50-1016
Bar Handle Kit	50-1012	50-1012	50-1012	50-1012	50-1012
Seal Cap Kit	50-1049	50-1049	50-1049	50-1049	50-1049
Gasket Kit	50-1040	50-1040	50-1040	50-1040	50-1040

BOLTED BONNET 1/2"-1-1/2" (13mm-40mm)

DESCRIPTION	NOMINAL SIZE inch (mm)				
	1/2 (13)	3/4 (20)	1 (25)	1-1/4 (32)	1-1/2 (40)
Throttling Plug Kit	50-1053	50-1054	50-1015	50-1016	50-1046
Bar Handle Kit	50-1012	50-1012	50-1012	50-1012	50-1039
Seal Cap Kit	50-1049	50-1049	50-1049	50-1049	50-1048
Gasket Kit	50-1040	50-1040	50-1040	50-1040	50-1023

BOLTED BONNET 2"-4" (50mm-100mm)

DESCRIPTION	NOMINAL SIZE inch (mm)			
	2 (50)	2-1/2 (65)	3 (80)	4 (100)
Throttling Plug Kit	50-1047	50-1059	50-1058	50-1063
Bar Handle Kit	50-1039	50-1051	50-1051	50-1051
Seal Cap Kit	50-1048	50-1050	50-1050	50-1050
Gasket Kit	50-1023	50-1043	50-1043	50-1065

PARTS LIST

ITEM	DESCRIPTION
1	Throttling Plug Kit: Throttling Plug
2	Ball Bearings
3	Ball Retainer
4a	Bonnet O-Ring
4b	Bonnet Gasket
5	Bar Handle Kit: Bar Handle
6	Screw
7	Washer
8	Bonnet Thread Cap
9	Seal Cap Kit: Seal Cap (yellow)
10a	Seal Cap O-Ring
10b	Seal Cap Gasket
4a	Gasket Kit: Bonnet O-Ring
4b	Bonnet Gasket
10a	Seal Cap O-Ring
10b	Seal Cap Gasket
11	Stem O-Ring
12	Stem Washer
13	Graphite Packing
14	Packing Nut
15	Anti-Spin O-Ring

SERVICE AND MAINTENANCE

Hansen hand expansion valves require practically no service or maintenance due to the combination of polished stainless steel stems and reliable o-ring stem seals plus graphite composite packing. This almost entirely eliminates stem leakage.

VALVE SEAT

To inspect or replace the valve throttling plug, isolate the valve from the system and safely pump out all refrigerant to zero pressure. With the stem open several turns, carefully remove the bonnet assembly. If the conical seat surface in the body is marred, remove the marks with emery paper. If the valve throttling plug is damaged, replace the entire throttling plug by first removing the ball retainer ring and ball bearings. Install a new throttling plug assembly including new bearings and retainer ring. Install new stem packing, stem o-ring, and bonnet o-ring/gasket, if necessary. Reassemble the bonnet into the valve body with the stem open several turns. Hansen assemblies 3/8" to 1-1/4" (10mm to 32mm) valves with screwed bonnets factory tightened to 75 ft-lb (102 Nm). Hansen assemblies valves with bonnet cap screws factory tightened as follows: 1/2" to 1-1/4" (13mm to 32mm)–30 ft-lb (41 Nm); 1-1/2" (40mm) and 2" (50mm)–40 ft-lb (54 Nm); 2-1/2" (65mm) and 3" (80mm)–60 ft-lb (81Nm); 4" (100mm)–180 ft-lb (244 Nm). Test for leaks and reset the valve to the correct number of turns open before returning it to service. Refer also to the current edition of Hansen shut-off valve bulletins:

- G109 – Threaded Shut-off Valves
- G209 – Socket Weld Shut-off Valves
- G359 – Butt Weld Shut-off Valves.

CAUTION

Hansen valves are for refrigeration systems only. These instructions must be completely read and understood before selecting, using or servicing Hansen valves and electronics. Only knowledgeable, trained refrigeration mechanics should install, operate, or service. Stated temperature and pressure limits should not be exceeded. Bonnets should not be removed from valves unless system has been evacuated to zero pressure. See also Safety Precautions in the current List Price Schedule and the Safety Precautions Sheet supplied with the product.

WARRANTY

All Hansen products, except electronics, are guaranteed against defective materials or workmanship for one year F.O.B. factory. Electronics are guaranteed against defective materials or workmanship for 90 days F.O.B. factory. No consequential damages or field labor is included.

TYPICAL SPECIFICATIONS

"Refrigerant hand expansion (flow regulating) valves shall have slotted or characterized throttling plugs, tight-closing Teflon seats, stainless steel stems, back-seating design for packing replacement, exterior bonnet threads for installation of stem seal caps on any valve, and be suitable for a safe working pressure of 400 psig (28 bar g), or 600 psig (41 bar g), are available as manufactured by Hansen Technologies Corporation or approved equal."

ORDERING INFORMATION

NOMINAL SIZE inch (mm)	DESCRIPTION	CAT NO	
		SEAL CAP	BAR HANDLE
3/8 (10)	Globe, Threaded, Screwed Bonnet	RT038C	RT038H
	Angle, Threaded, Screwed Bonnet	VT038C	VT038H
1/2 (13)	Globe, Threaded, Screwed Bonnet	RT051C	RT051H
	Globe, Threaded, Bolted Bonnet	RTB051C	RTB051H
	Globe, Socket Weld, Bolted Bonnet	RSB051C	RSB051H
	Globe, Butt Weld, Bolted Bonnet	RWB051C	RWB051H
	Angle, Threaded, Screwed Bonnet	VT051C	VT051H
	Angle, Threaded, Bolted Bonnet	VTB050C	VTB050H
	Angle, Socket Weld, Bolted Bonnet	VSB050C	VSB050H
	Angle, Butt Weld, Bolted Bonnet	VWB050C	VWB050H
3/4 (20)	Globe, Threaded, Screwed Bonnet	RT076C	RT076H
	Globe, Threaded, Bolted Bonnet	RTB076C	RTB076H
	Globe, Socket Weld, Bolted Bonnet	RSB076C	RSB076H
	Globe, Butt Weld, Bolted Bonnet	RWB076C	RWB076H
	Angle, Threaded, Screwed Bonnet	VT076C	VT076H
	Angle, Threaded, Bolted Bonnet	VTB075C	VTB075H
	Angle, Socket Weld, Bolted Bonnet	VSB075C	VSB075H
	Angle, Butt Weld, Bolted Bonnet	VWB075C	VWB075H
1 (25)	Globe, Threaded, Screwed Bonnet	RT100C	RT100H
	Globe, Threaded, Bolted Bonnet	RTB101C	RTB101H
	Globe, Socket Weld, Bolted Bonnet	RSB101C	RSB101H
	Globe, Butt Weld, Bolted Bonnet	RWB101C	RWB101H
	Angle, Threaded, Screwed Bonnet	VT100C	VT100H
	Angle, Threaded, Bolted Bonnet	VTB100C	VTB100H
	Angle, Socket Weld, Bolted Bonnet	VSB100C	VSB100H
	Angle, Butt Weld, Bolted Bonnet	VWB100C	VWB100H
1-1/4 (32)	Globe, Threaded, Screwed Bonnet	RT125C	RT125H
	Globe, Threaded, Bolted Bonnet	RTB126C	RTB126H
	Globe, Socket Weld, Bolted Bonnet	RSB126C	RSB126H
	Globe, Butt Weld, Bolted Bonnet	RWB126C	RWB126H
	Angle, Threaded, Screwed Bonnet	VT125C	VT125H
	Angle, Threaded, Bolted Bonnet	VTB125C	VTB125H
	Angle, Socket Weld, Bolted Bonnet	VSB125C	VSB125H
	Angle, Butt Weld, Bolted Bonnet	VWB125C	VWB125H
1-1/2 (40)	Globe, Socket Weld	RS150C	RS150H
	Globe, Butt Weld	RW150C	RW150H
	Angle, Socket Weld	VS150C	VS150H
	Angle, Butt Weld	VW150C	VW150H
2 (50)	Globe, Socket Weld	RS200C	RS200H
	Globe, Butt Weld	RW201C	RW201H
	Angle, Socket Weld	VS200C	VS200H
	Angle, Butt Weld	VW201C	VW201H
2-1/2 (65)	Globe, Butt Weld	RW251C	RW251H
	Angle, Butt Weld	VW251C	VW251H
3 (80)	Globe, Butt Weld	RW301C	RW301H
	Angle, Butt Weld	VW301C	VW301H
4 (100)	Globe, Butt Weld (Y-Style Body)	RW402C	RW402H
	Angle, Butt Weld	VW402C	VW402H

Note for Bolted Bonnet Valves only: To order valves with extended neck, add "E" to catalog number (Example: RSE076H or VWE251C). The extended neck RWE400 (C or H) is a T-style body. To order valves for 600 psig (41 bar g) SWP, add the letter "C" prefix to catalog number (Example: CRSB076H or CVW201C). CE marked valves are available, add the letter "E" suffix to catalog number of bolted bonnet valves 1-1/4" (32mm) and larger (Example: RS150CE).

H HANSEN

Hansen Technologies Corporation

400 Quadrangle Drive, Suite F

Bolingbrook, Illinois 60440 USA

Tel: 630.325.1565 Fax: 630.325.1572 Toll: 866.4HANSEN

Email: sales@hantech.com Web: www.hantech.com

USA • Asia • Europe • India • Latin America • Middle East

© 2013 Hansen Technologies Corporation