

# NON-ELECTRICAL AUTO-PURGER® (NEAP)

ISO 9002



Model NEAP  
(Shown with optional valve package VPM)

Automatic Noncondensable Gas (Air) Refrigerant Purger  
for Ammonia

## OPERATOR INSTALLATION & INSTRUCTION MANUAL

## OPERATING SPECIFICATIONS

Safe Working Pressure: 400 psig (27 bar)

Operating Temperature: -60°F to +240°F  
(-51°C to +115°C)

## INTRODUCTION

The Non-Electrical AUTO-PURGER® (NEAP) is a simplified version of the popular Hansen AUTO-PURGER®s. It is designed to remove non-condensable gases, mostly air, from an ammonia refrigeration system, resulting in lower energy costs for the system. The NEAP features welded-pipe, all steel construction and comes preassembled and tested, unlike the Armstrong purger which is shipped as unassembled components and pipes. The simple, heavy-duty design makes the NEAP especially suited for industrial refrigeration systems and does not require sophisticated training for the operators.

An optional valve package is available that is easily installed and includes the necessary shut-off valves and gauge valves for the foul gas, suction, and liquid lines. See page 8 for details.

## ADVANTAGES

The Non-Electrical AUTO-PURGER (NEAP) is lower in cost compared to other purgers. It also has a greater air removal capacity than the Armstrong and other purgers. The NEAP is more versatile than the small Grasso purger and has nearly ten times the air removal capacity rate. The Grasso purger must be located directly above the purge point. The NEAP can be located at any convenient location. In addition, the Grasso purger must be protected against rain and other elements. Since the NEAP is non-electrical and has no external moving parts, it can be located anywhere, regardless of the elements.

Unlike other competitive non-electrical purgers, the NEAP features fully-automatic start-up. By opening the shut-off valves, the purger then primes itself with refrigerant, cools down, processes foul gas, and releases any noncondensable gases present into a water reservoir.

This purger is capable of handling package units or small plants having a capacity of up to about 100 tons (350 kW), depending on the quantity of noncondensable gases present in the system. The non-electrical design makes the NEAP ideal for explosion proof installations. Its compact design allows easy mounting on skidded refrigeration packages. For larger-capacity purgers, see page 8.

## INSTALLATION AND START-UP

1. The NEAP is normally installed in the compressor room where it can be monitored, but can also be installed outdoors. Mount the purger straight and level, using at least four bolts to secure it on a wall or steel beam capable of supporting 150 lbs (66 Kg). See Installation Dimensions to the right.
2. Connect the suction, foul gas, and liquid lines to the purger. The suction line from the purger *must* be connected to a protected suction vessel. For best noncondensable gas

separation efficiency, connect to the lowest-temperature suction in the plant. The liquid line *must* be connected to a high-pressure receiver at a point free from oil. The foul gas line should be a minimum of 1/2" pipe size and should pitch down toward the purger. This line to the purger should not have any traps and should not pass through cold areas where condensing of the saturated gas can occur. Connect the pressure relief valve to appropriate piping, per accepted codes.

3. Run the 3/8" diameter nylon purge gas tubing to an ammonia-absorbing water reservoir.
4. Open the foul gas line valve to pressurize the purger. Check all piping for leaks. Note: The NEAP is leak-tested at the factory.
5. Then, fully open the liquid line and suction line valves in any order. Next, open the purge point isolation valve, if used. The purger is now in operation.

Note: To start-up the purger after it has been installed, the foul gas, liquid, and suction lines can be opened in any order. To shut-down the purger, close the liquid and foul gas lines in any order. Then, when the purger is defrosted, close the suction line valve. Refer to the PURGER SHUT-DOWN and PURGER PUMP-OUT PROCEDURE FOR SERVICE sections on page 5 for detailed instructions.

## INSTALLATION DIMENSIONS (MM)

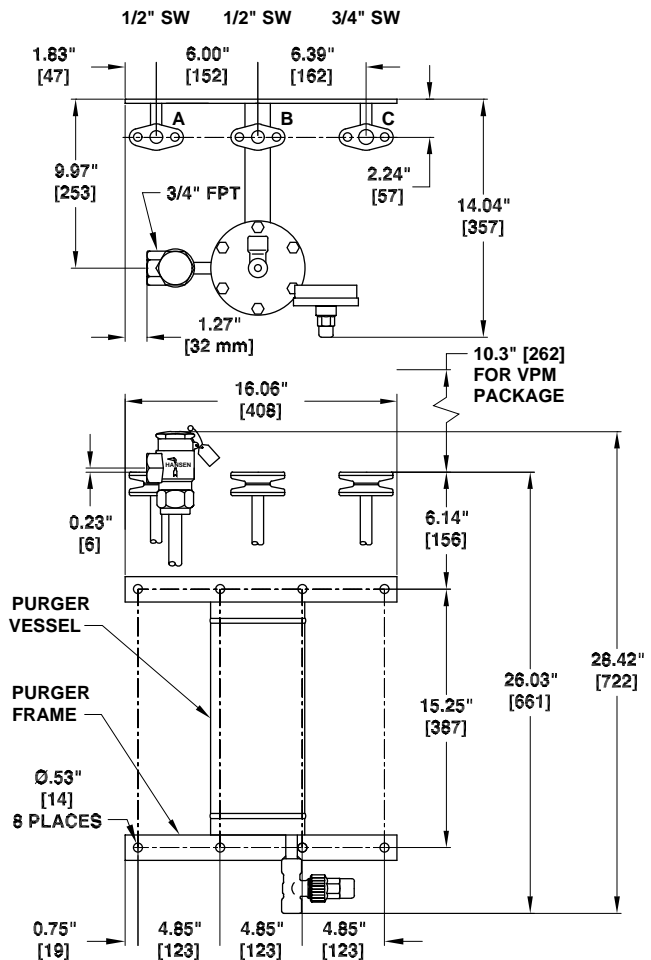

NOTE: MOST COMPONENTS REMOVED FOR CLARITY. FOR DETAILED DRAWINGS, SEE PAGES 6 AND 7.

## PURGE POINT LOCATION

Purge points should be located where non-condensable gases tend to collect on the high-pressure side of the refrigeration system. If more than one purge point is piped to the NEAP, *only one purge point shut-off valve should be open at a time*. A Hansen H8021 3-way shut-off valve can be connected at the purger to purge from two alternating purge points.

Typically, ammonia evaporative condenser outlet liquid drain lines must drop a minimum of 4 feet (1.2 m) to the P-trap leading to the receiver. A properly-sized equalizer line used in conjunction with a P-trap will help drain liquid from the condenser into the receiver. The P-trap also concentrates air prior to the receiver. Refer to ASHRAE guidelines, IAR papers, and the condenser manufacturer's installation instructions for additional piping and

sizing information. Most air from the system will normally collect between the condenser and the P-trap. **Avoid using one purge point shut-off valve to control purging for two circuits.** The foul gas line should pitch down toward the purger. No traps are allowed in the foul gas line.

Shell and tube heat exchangers and condensers should be purged at the top, usually at the point farthest from the compressor discharge main inlet to the vessel. When a high-pressure float regulator is used, the top of the float valve chamber should have a purge point. Flat plate condensing heat exchangers should be purged at the outlet during operation. It is not necessary to purge control pressure receivers, high-pressure thermosyphon vessels, or vessels located on the low-pressure side of the system.

## TYPICAL APPLICATIONS

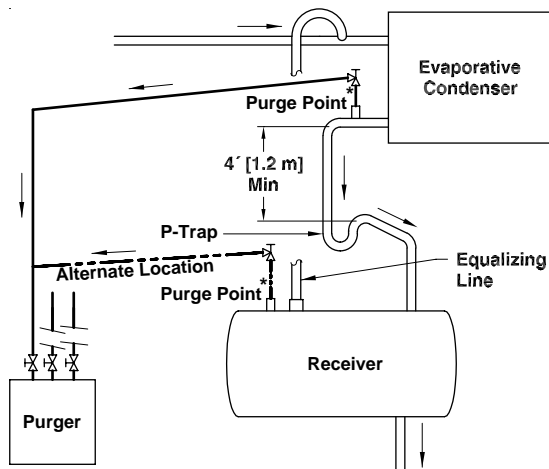

**Evaporative Condenser**

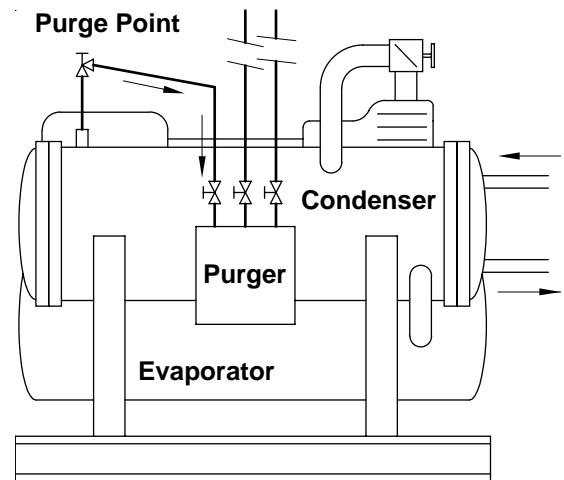

**Skidded Refrigeration Package**

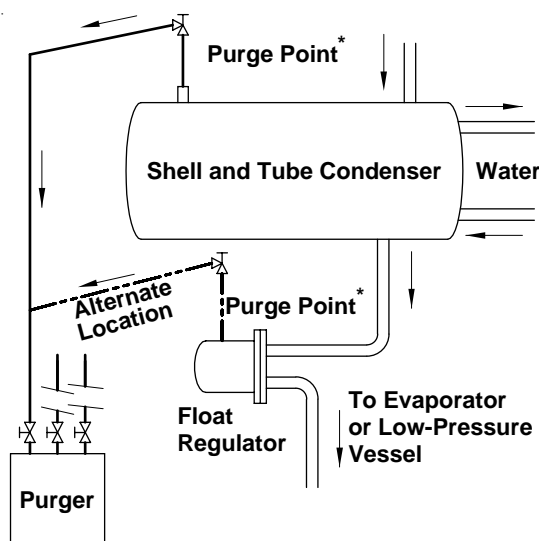

**Shell and Tube Condenser**

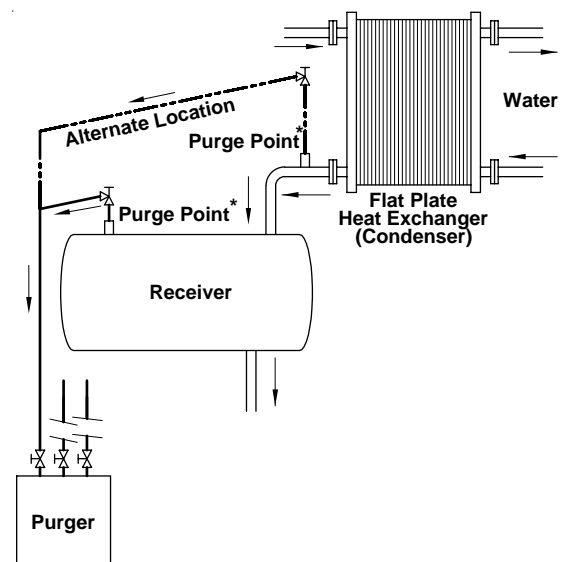

**Flat Plate Heat Exchanger**

Note: The above drawings are for illustrations purposes only. They are not intended for engineering or design purposes.  
\*Only one purge point shut-off valve should be open at a time.

## PURGER OPERATION

Start the purger by opening the foul gas line (A), liquid line (B), and suction line (C) valves in any order. Make sure that the purge gas shut-off valve (E) is open. Also, open the purge point isolation valve if used.

Foul gas passes through the strainer (4) and enters the liquid drainer (6) where any liquid refrigerant that may be present is separated from the vapor and bled to the inlet of the low-pressure evaporator coil via the strainer/orifice (5a). Liquid at or below the 50% line of the sight glass (7) is normal. The liquid-free foul gas exits the top of the liquid drainer through the ball check valve (3) and enters the bottom of the purger vessel.

At the same time, high-pressure liquid refrigerant passes through the thermostatic expansion valve (1), is changed to a low-pressure liquid, and enters the evaporator coil inside the purger vessel. The thermostatic expansion valve senses the superheat of the gas exiting the coil and makes up liquid as needed during start-up. The coil cools the foul gas inside the purger vessel, thereby condensing refrigerant from the vapor. This fills the vessel with liquid. During normal operation, the foul gas bubbles up through a bath of cold liquid refrigerant. The refrigerant condenses and the noncondensable gases collect at the top of the vessel. As noncondensable gases collect at the top of the purger, the level of liquid refrigerant in the purger vessel drops, causing the float ball (12) to drop.

Noncondensable gases are released from the top of the purger vessel via the float ball plunger/seat assembly (11 and 13). In order for noncondensable gases to be released to the water reservoir, the pressure inside the purger must be above 80 psig (5.4 bar) and the temperature of the purger must be at or below +40°F (+4.4°C). When these conditions are met, the noncondensable gases then pass through the temperature valve/check valve combination (9) and 1 psid inline check valve (2) to the water reservoir via the purge gas tubing.

As noncondensable gases are released from the purger, the level of liquid refrigerant in the purger vessel rises. When noncondensable gases are removed from the system, the float ball (12) rises forcing the plunger assembly (11) onto the seat (13), stopping flow to the water reservoir. This prevents the release of refrigerant.

The refrigerant condensed from the foul gas is bled back to the low-pressure inlet of the purger's evaporator coil via the strainer/orifice (5b) and is used to cool the incoming foul gas.

If there is an over pressure of noncondensable gases inside the purger vessel above 225 psid (15.3 bar), the check valve (10) bleeds pressure to the suction line until the pressure difference drops below 225 psid (15.3 bar). In addition, the purger is protected by a 300 psig (20.4 bar) setting pressure relief valve (8). Relief valve piping should be in compliance with appropriate codes.

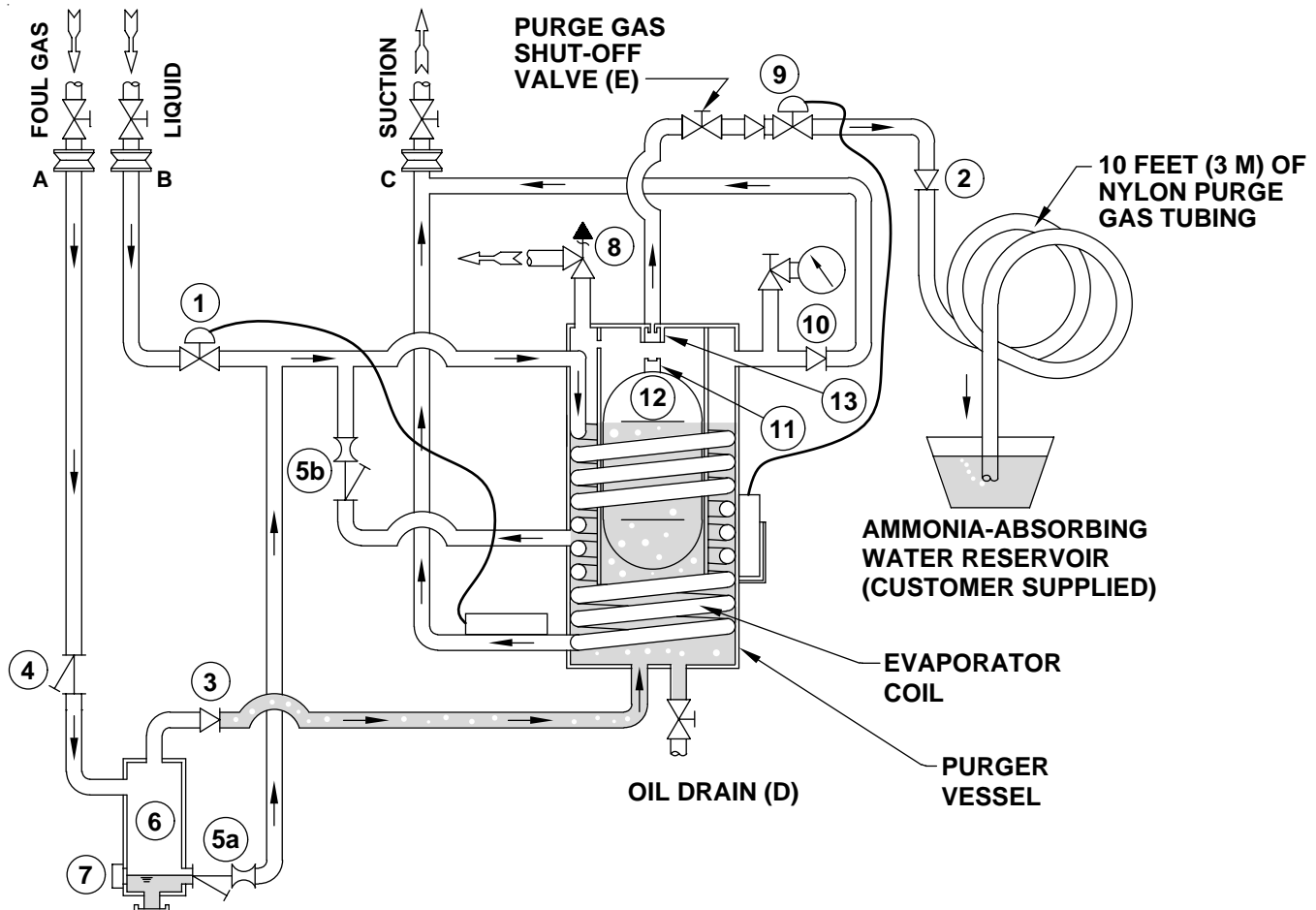

## PURGER SHUT-DOWN

To shut down the NEAP purger when purging is not needed, simply close the foul gas line valve (A) and liquid line valve (B). Leave the suction line valve (C) open to pump-out liquid from the purger and to prevent pressure from building inside the purger while it is not in operation.

It is not necessary to shut-down the purger during normal compressor off-cycles. The temperature/check valve closes to prevent refrigerant from escaping during warm up between cycles.

## PURGER PUMP-OUT PROCEDURE FOR SERVICE

**Important:** Observe all standard refrigeration safety practices. Safety eye goggles should be worn whenever installing or servicing refrigeration system components. See also the Caution section on page 8.

1. Close the liquid line valve (B) and foul gas line valve (A).
2. Leave the suction line valve (C) open to allow the purger to pump-out any remaining liquid.
3. The purger will slowly defrost as liquid evaporates. Continue pumping out until the purger is no longer frosted, indicating that all liquid has exited the purger.
4. Close the suction line valve (C) and the purge gas shut-off valve (E). The purger is now isolated. Remove the purge gas tubing from the water reservoir to prevent the possibility of reverse flow of water into the purger.
5. Safely bleed any remaining pressure from the purger using accepted procedures.
6. With all refrigerant removed (pumped out to zero pressure), slowly open the oil drain (D) on the bottom of the purger vessel to verify zero pressure. Once zero pressure is verified, the purger can be disconnected from the system or opened as needed for service.
7. If the purger is removed from the system, cap the suction, foul gas, and liquid lines to the system using blanking flanges.

## OIL DRAIN

The NEAP has a valve and connection (D) on the bottom of the purger vessel for draining oil. Excess oil in the purger can reduce its capacity by lowering the evaporating or condensing rate. Typically, oil is not a problem unless the liquid line is connected to a vessel or line where oil can drain into the purger.

Before draining any oil, safely pump-out the purger as indicated in the Purger Pump-Out Procedure section and allow the purger to warm to ambient temperature. Use accepted oil draining precautions to prevent injury or property damage. Once all oil has been drained from the purger, close the oil drain valve (D) and return it to normal operation, as indicated in the Installation and Start-Up section.

## TROUBLESHOOTING

### NO NONCONDENSIBLE GAS BEING RELEASED FROM THE PURGER

Reason 1: **The purge gas shut-off valve (E) is closed.**  
Check: **Verify that the valve is open.**

Reason 2: **There are no noncondensibles gases present in the system.**

Check: **Measure the temperature of the liquid leaving the condenser and measure the condensing pressure. Compare the condensing pressure to the saturation pressure for the measured temperature. If the pressures are the same, there are very little, if any, noncondensibles gases in the system.**

Reason 3: **The purger evaporator temperature is not at +40°F (+4.4°C) or below. The temperature/check valve (9) will be closed.**

Check: **Verify that suction pressure at the purger is below 58.6 psig (4 bar).**

Reason 4: **Inadequate liquid supply.**

Check: **Make sure all liquid line shut-off valves leading to the purger are open and the strainer in the thermostatic expansion valve (1) is not clogged.**

Reason 5: **The strainer/orifice (5b) is clogged.**

Check: **No frost on the strainer/orifice indicates a clogged strainer.**

Reason 6: **No foul gas pressure at the purger.**

Check: **The pressure gauge on the purger should read condensing pressure. If more than approximately 10 psi (.68 bar) below condensing pressure, there is a restriction in the foul gas line or the foul gas line shut-off valve (A) is closed. Check to make sure the strainer (4) is not clogged.**

Reason 7 : **The temperature/check valve (9) is clogged.**

Check: **Look for an obstruction inside the temperature/check valve and remove it. Clean and inspect the check valve assembly (19), and replace if needed.**

Reason 8: **Liquid, not vapor, in the foul gas line.**

Check: **Look for frost after the strainer/orifice (5a) or liquid above the 50% level in the sight glass (7). Verify that the purge point is located at the top of a pipe or vessel where no liquid is present. Relocate if needed.**

Reason 9: **The 225 psid check valve (10) is leaking.**

Check: **If the pressure difference is below 225 psid and the outlet of the check valve is frosted, replace the seat/poppet assembly and spring if necessary.**

### AMMONIA GAS BEING RELEASED FROM THE PURGER IN NOTICEABLE QUANTITIES

Reason 1: **The float ball plunger or seat is leaking.**  
Check: **Verify the condition of the plunger seating surface. It should be clean and without scratches. Replace if needed. Verify the condition of the seat (13) and replace if needed.**

Reason 2: **The temperature/check valve is inoperative.**

Check: **The power element may have lost its charge. Look for cracks or holes in the power element and related tubing. Replace the element if needed. Also, check for dirt in the check valve assembly or on the temperature valve seat.**

PARTS

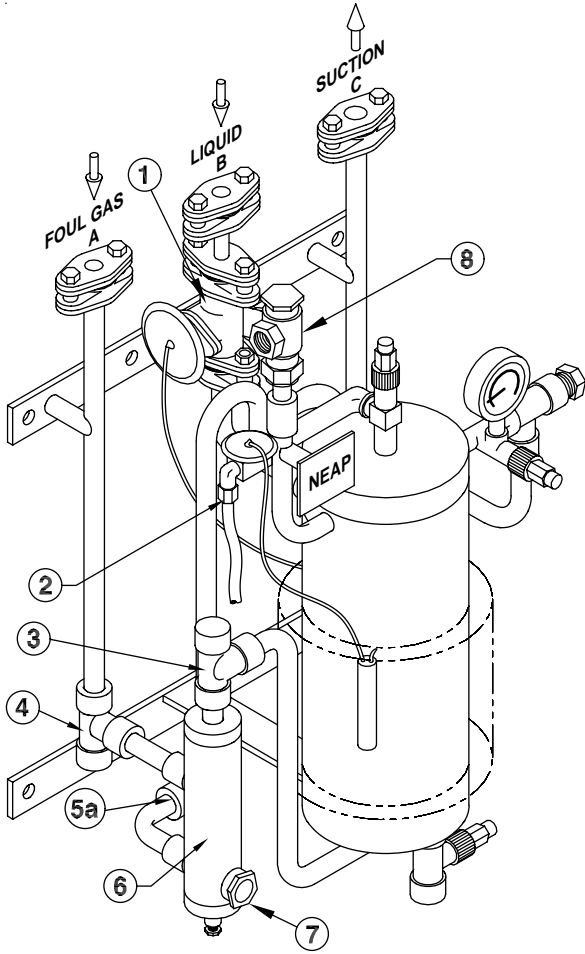

Left-Hand Side

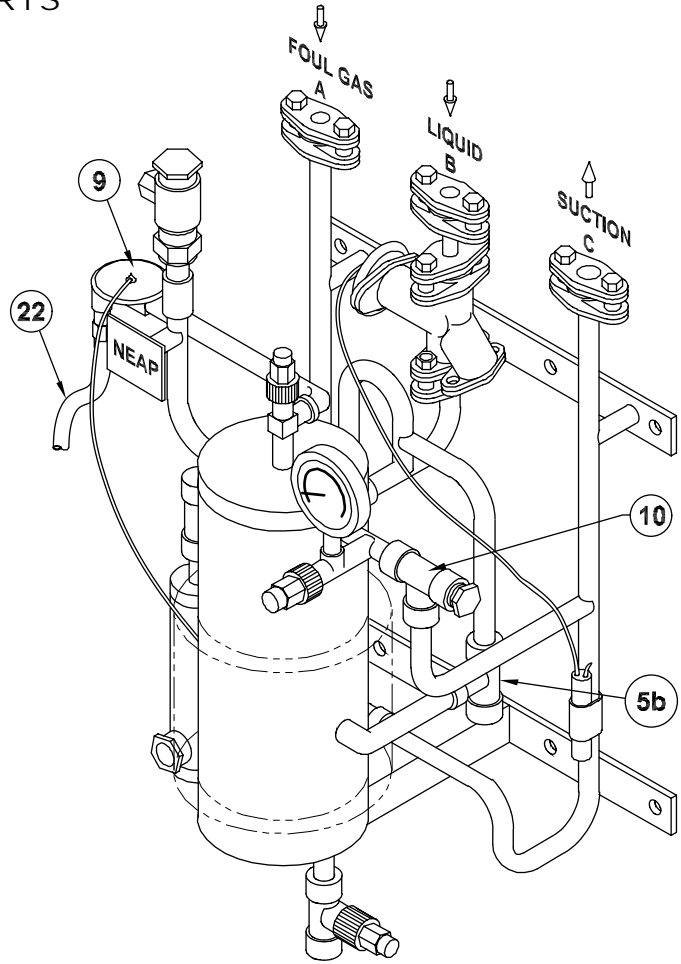

Right-Hand Side

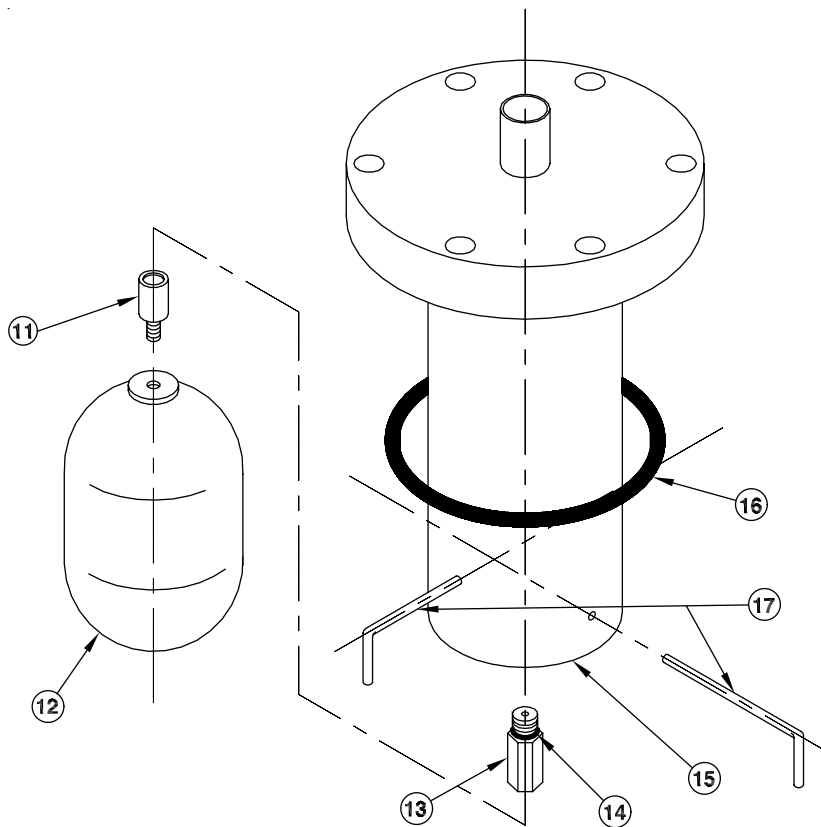

Purifier Vessel Cover and Float Ball Assemblies

PARTS LIST

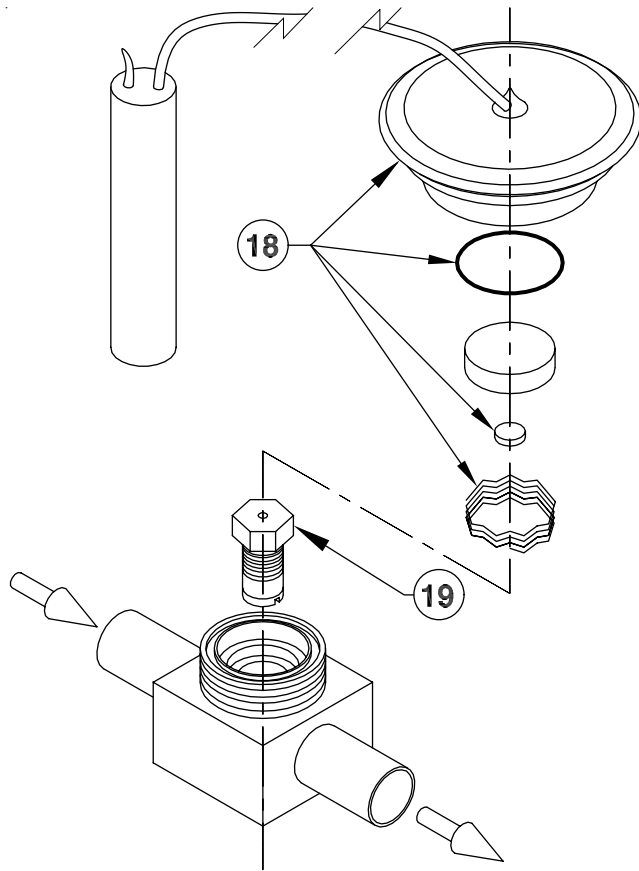

**Combination Temperature/Check Valve (9)**

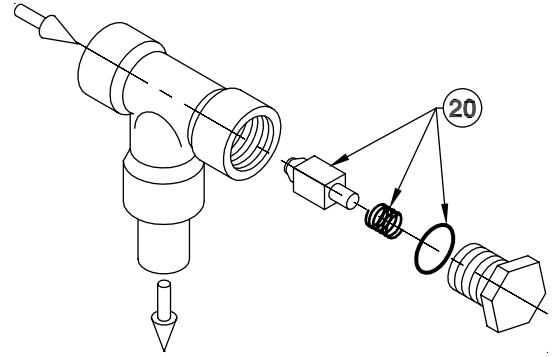

**225 psid Check Valve (10)**

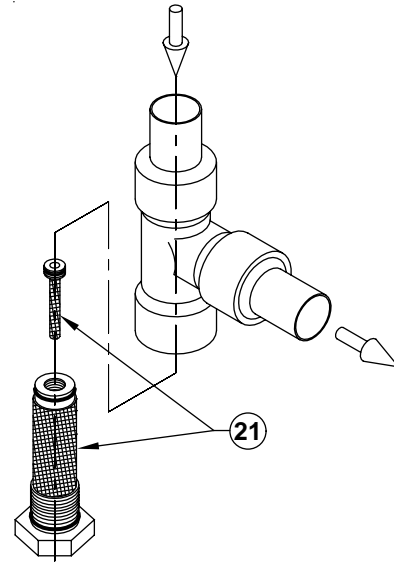

**Strainer/Orifice (5a, 5b)**

Item	Description	Part Number
1	Thermostatic Expansion Valve	20-2163
2	Inline Check Valve, 1psid	20-1183
3	Ball Check Valve: Ball	20-1187
4	Strainer Kit: Strainer screen and O-ring	78-1010
5a, 5b	Strainer/Orifice	N/A
6	Liquid Drainer	N/A
7	Sight Glass	N/A
8	Pressure Relief Valve, 300 psi	H5600/300
9	Combination Temperature/Check Valve	N/A
10	Check Valve, 225 psid	N/A
11	Float Ball Plunger	20-2201
12	Float Ball	77-0036
13	Float Ball Seat	20-2202
14	O-ring, Float Ball Seat	20-2166
15	Vessel Cover Assembly	N/A
16	Vessel Cover O-ring	20-2167
17	Float Ball Retaining Wires (2 per kit)	20-2173
18	Temperature Valve Assembly Kit	20-2200
19	80 psi Check Valve Assembly, Temperature Valve	20-2199
20	225 psi Check Valve Kit	20-2204
21	Screen Assembly	20-2203
22	10 feet (3 m) of Nylon Purge Gas Tubing	20-1242

## VALVE PACKAGE (VPM)

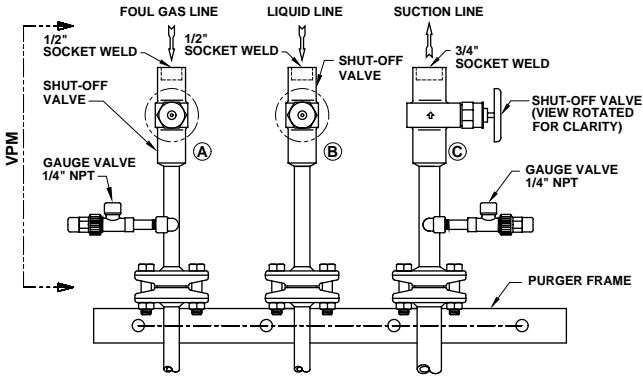

The valve package (VPM) provides an easy means of connecting the Non-Electrical AUTO-PURGER® (NEAP) to the refrigeration system. It consists of three welded assemblies that contain the necessary valves and flanges to ensure proper connections without the need to purchase separate valves. This bolt-on valve package provides the three shut-off valves required for purger operation and also facilitates purger isolation for shut-down, routine maintenance, or troubleshooting purger operation. When ordering the NEAP, specify the VPM option for the Hansen shut-off valve package.

### CAUTION

Hansen purgers are for refrigeration systems only. These instructions and related safety precautions must be read completely and understood before selecting, using, or servicing these purgers. Only knowledgeable, trained refrigeration technicians should install, operate, or service these purgers. Stated temperature and pressure limits should not be exceeded. Purger components should not be removed from the purger unless the system has been evacuated to zero pressure. See also the Safety Precautions in the current List Price schedule and the Safety Precautions Sheet supplied with the product. Escaping refrigerant can cause injury, especially to the eyes and lungs.

### WARRANTY

All mechanical components are guaranteed against defective materials or workmanship for one year FOB our plant. No consequential damages or field labor is included.

### DEFINITIONS

**Noncondensable gases:** These gases, primarily air, cannot be condensed by normal system operating temperature and pressure. They cause higher-than-necessary head pressure. Noncondensable gases can enter a refrigeration system through vacuum leaks, break down of oil and refrigerant, and during service repairs and system charging.

**Foul gas:** A vapor mixture of noncondensable gases and refrigerant gas.

**High-pressure liquid:** Refrigerant liquid source from a condenser or receiver.

**P-trap:** A piping arrangement, typically in condenser drain lines, to prevent passage of gas while enabling liquid to proceed.

**Purge point:** A location on the refrigeration system where foul gas is taken from and piped to the purger.

**Purge gas:** The noncondensable result of the separation of refrigerant gas from the foul gas by the purger. Normally passed into a water bubbler or water reservoir.

## SELECTING AN AUTO-PURGER®

In addition to the Non-Electrical AUTO-PURGER® (NEAP), Hansen Technologies offers two other versions—the original AUTO-PURGER® AP and the compact AUTO-PURGER® APM. Use the following descriptions to help select the best AUTO-PURGER for your needs. For additional assistance, contact the factory.

### AUTO-PURGER AP

This is the original AUTO-PURGER. It has solid-state control and is ideal for larger systems, up to 1500 tons (5275 kW). This is two to three times the air removal capacity of the Armstrong purger. With models available to purge up to 24 points, the AP features automatic start-up with electronic control. The purge cycles can be individually adjusted to meet system requirements. The AP includes an automatic water bubbler. An optional NEMA 4 rated enclosure is available. A European option is available that features all-welded construction and conformance to European electrical standards. For ammonia and halocarbon refrigeration system. Assembled, tested, and ready to run.



### AUTO-PURGER APM

A more compact version of the original AP, the AUTO-PURGER APM is ideal for medium-size systems, up to 200 tons (703 kW). Like the AP, the APM features automatic start-up with electronic control. Designed for up to four purge points, an electronic “brain” searches for noncondensable gases in the system and purges at those points where air is present. The APM includes an automatic water bubbler and comes standard with a NEMA 12,13 control cabinet. For use with ammonia refrigeration systems. Assembled, tested, and ready to run.



### NON-ELECTRICAL AUTO-PURGER (NEAP)

The Non-Electrical AUTO-PURGER (NEAP) is ideal for small systems. The non-electrical design also makes the NEAP ideal for explosion proof applications. The simple design of the NEAP features fully automatic start-up, like the other AUTO-PURGERS, and is generally used to purge a single point. Three shut-off valves or the Hansen VPM valve package are required to operate this purger. For use with ammonia refrigeration systems. Assembled, tested, and ready to run.

## HANSEN TECHNOLOGIES CORPORATION

6827 High Grove Boulevard  
Burr Ridge, Illinois 60521 U.S.A.  
Telephone: (630) 325-1565  
Toll-free: 1-800-426-7368  
FAX: (630) 325-1572