



Model MCV

INTRODUCTION

The Hansen Motorized Control Valve is a truly unique motor operated valve which eliminates the most common concern of other motor operated valves—valve stem seal leakage. The Motorized Control Valve has no valve stem seal because the non-electric rotor is enclosed in a stainless steel cartridge which contains the fluid pressure. The electric stator is outside the stainless steel can, and is isolated from the fluid in the valve.

APPLICATIONS

Liquid Make-up to Accumulator
Liquid Injection to Compressors
DX Evaporators
Temperature or Pressure Control
Low or High Side Level Control
Slow Opening and Closing: Suction Stop Valve
No Pressure Drop: Gravity Drain
Modulating or Slow Open/Close Solenoid Operation

ADDITIONAL FEATURES

- Relay, current, or voltage input for direct connection to plant PLC or computer.
- All moving parts are sealed so that frost will not affect operation.
- Tight closing Teflon seat.
- Canned rotor eliminates valve stem seal leakage.
- Controlled opening and closing minimizes liquid velocity shock, “water hammer.”
- Valve is more compact and light weight than other motor operated valves.
- Same flanges and spacing as Hansen HA4A/HS4A pressure regulators and solenoid valves.
- Suitable for use with ammonia, R22, R134a, CO2 (up to 800 psi welded) glycol, water, brines, and other approved refrigerants.
- Available with optional Power-Backup feature.
- Valve position indicator display included.
- Available with weld-in connections.

Specifications, Applications, Service Instructions & Parts

MOTORIZED CONTROL VALVE & CONTROLLERS

3/4" - 2"
20mm thru 50mm
Motor Operated Valve



KEY FEATURES

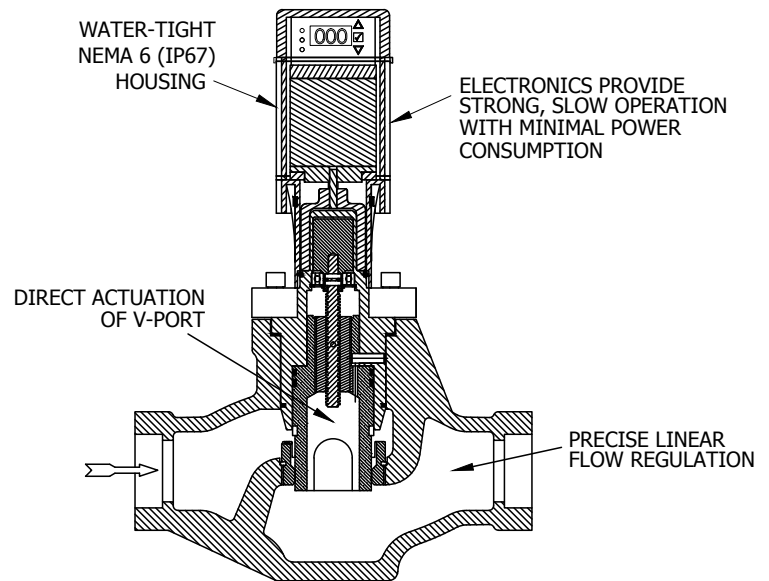

TABLE OF CONTENTS

Introduction/Specifications.....	1-2
Applications.....	3-5
Capacity Tables.....	6-14
Operation & Electrical.....	15
Wiring Diagrams.....	16-20
Installation Dimensions.....	21-24
Service & Maintenance.....	25
Parts.....	26
Piping Recommendations.....	27-28
Valve Controllers.....	29-36
Troubleshooting.....	37
Order Information.....	38

MATERIAL SPECIFICATIONS

Mechanical

Maximum Safe Working Pressure:
400 psig (28 bar) flanged, 800 psig (55 bar) welded
Maximum Opening Pressure Differential:
400 psig (28 bar) flanged, 800 psi (55bar) all sizes
Ambient Operating Temperature:
-40°F to 122°F (-40°C to 50°C)
Refrigerant Operating Temperature:
-75°F to 240°F (-60°C to 115°C)
IP67 Rating (NEMA 6)

Electrical:

Supply Voltage: 24VAC or 24VDC via NEC Class 2 Source
Power Draw: 20W per valve
Input Control Signal Types: 4-20mA, 0-20mA, 0-5VDC, 0-10VDC, 1-6VDC, relay closed contact
Output Feedback Signal Types: 0-20mA, 4-20mA

Material Specifications

Body: Ductile iron, ASTM V536
Bonnet Plate: Steel, zinc plated with yellow chromate
V-port Seal: Teflon
Cartridge Assembly: Stainless Steel
Cartridge O-ring: Neoprene
Powerhead Housing: Aluminum
Corrosion Protection: Zinc plating is standard on bodies up to 1-1/4"

APPLICATIONS

The Hansen Motorized Control Valve is ideal for applications where external leakage is intolerable. The valve is suitable for use with a variety of fluids, including those that are incompatible with copper, such as ammonia, because the copper windings of the motor stator are isolated from the fluid in the valve. Typical uses include slow opening solenoid valve, temperature controlled evaporator regulator, liquid injection to screw compressors, pressure control, liquid level control of pump accumulators, high side receivers or low side flooded chillers, or as a gravity drain valve.

The full ported **MCV** valve series is best suited for computer controlled operations using 4-20 mA signals. The MCV is ideal for precise temperature and pressure control, hot gas defrost, and other applications where accurate process control is required.

The full ported **MCV** valve series is best suited for applications requiring open/close operation only. (Floating Point Control)

The **MCR** valve with expansion plug is for high pressure drop applications such as liquid makeup and liquid injection. The MCR valve series is also suitable for suction line, liquid line and hot gas line where reduced capacities more closely match the expected operating conditions.

Refer to pages 3-5 for typical applications.

ADVANTAGES

No pressure drop is required to operate, unlike most pressure regulators and solenoid valves which require a minimum 2 psi pressure drop to keep the valve fully open. The Motorized Control Valve can be used for applications which require a very low pressure drop (e.g. suction lines), or no pressure drop (e.g. equalizing or drain lines).

Valves are drop-in replacement for Hansen and other select solenoid and pressure regulating valves.

The Motorized Control Valve does not require stem shaft heaters like other open motorized valves.

The Motorized Control Valve is slow opening and closing (about 15 to 27) seconds depending on valve size and speed settings which minimizes the potential for liquid velocity shock or "water hammer" often experienced with quick opening and closing solenoid valves.

POWER BACKUP FEATURE

The Motorized Control Valve is available with an optional power backup system that will control the valve to a user defined location upon a loss of the incoming voltage. This system can be used in place of an upstream solenoid to the valve.

VALVE SIZING

Proper valve sizing is important for smooth operation and long, trouble-free life of the valve. Therefore, capacity at both the maximum and minimum flow and Pressure Drop should be analyzed. Pressure drop across the valve dramatically increases the capacity of the valve. A valve with 8 psi pressure drop has twice the capacity of a valve with a 2 psi pressure drop. Ideally, valves should operate between 15% and 85% open for optimum trouble-free control. Refer to the capacity tables on pages 6-14 or the Hansen sizing program found at www.hantech.com.

LIQUID MAKE-UP APPLICATIONS

For applications with a large pressure drop across the Motorized Control Valve, attention must be paid to proper outlet line sizing to accommodate flash gas. It is recommended that dual Motorized Control Valves in parallel be used when the low load (weekend load) is less than 15% of the properly sized full load capacity for the application. Also, for applications requiring a valve size over 2" port size, it is strongly recommended that two liquid make-up valves in parallel be used. This valve arrangement could be two Motorized Control Valves or one solenoid valve with hand expansion valve and one Motorized Control Valve to be used as a "trim" valve under low load conditions.

LIQUID LINE SIZING

Liquid lines should be adequately sized for the capacity of the valve. Listed below are the IIAR recommended capacities for liquid lines. R22 capacities based on 3 ft/s liquid velocity. For R134a, use 94% of R22 capacity; R404 80%; R507 60%.

TABLE 1

LINE SIZE	MAXIMUM CAPACITY AMMONIA		MAXIMUM CAPACITY R22	
	Tons	kW	Tons	kW
1/2"	32 Tons	112 kW	8 Tons	27 kW
3/4"	58 Tons	208 kW	14 Tons	49 kW
1"	97 Tons	340 kW	24 Tons	82 kW
1-1/4"	179 Tons	625 kW	42 Tons	147 kW
1-1/2"	254 Tons	890 kW	58 Tons	202 kW
2"	496 Tons	1740 kW	110 Tons	384 kW
2-1/2"	729 Tons	2550 kW	155 Tons	543 kW
3"	1160 Tons	4060 kW	241 Tons	845 kW
4"	2040 Tons	7140 kW	416 Tons	1457 kW
5"	3300 Tons	11606 kW	654 Tons	2289 kW
6"	4890 Tons	17198 kW	946 Tons	3309 kW

NH3 capacities are based on IIAR Refrigeration Piping Handbook tables.

TYPICAL APPLICATIONS: MCV MOTORIZED CONTROL VALVE

LIQUID MAKE-UP TO ACCUMULATOR

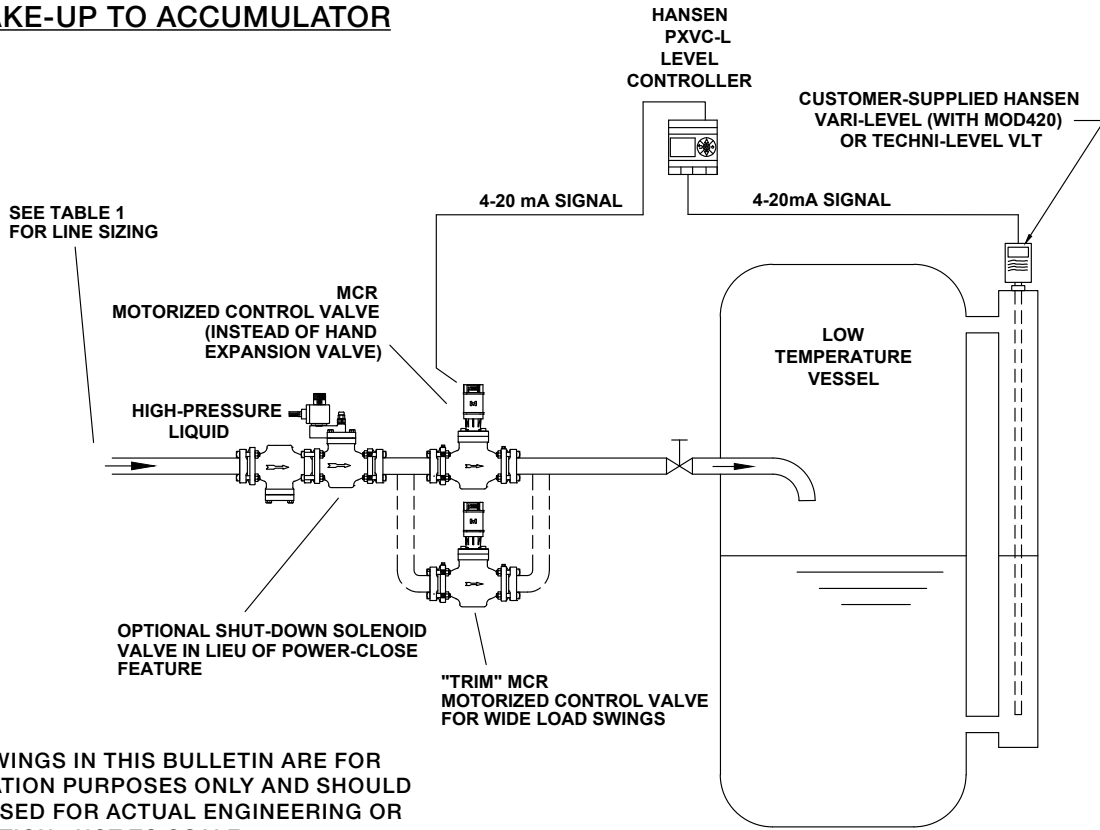

ROOM TEMPERATURE OR EVAPORATOR PRESSURE CONTROL

(Shown with Pressure Transducer)

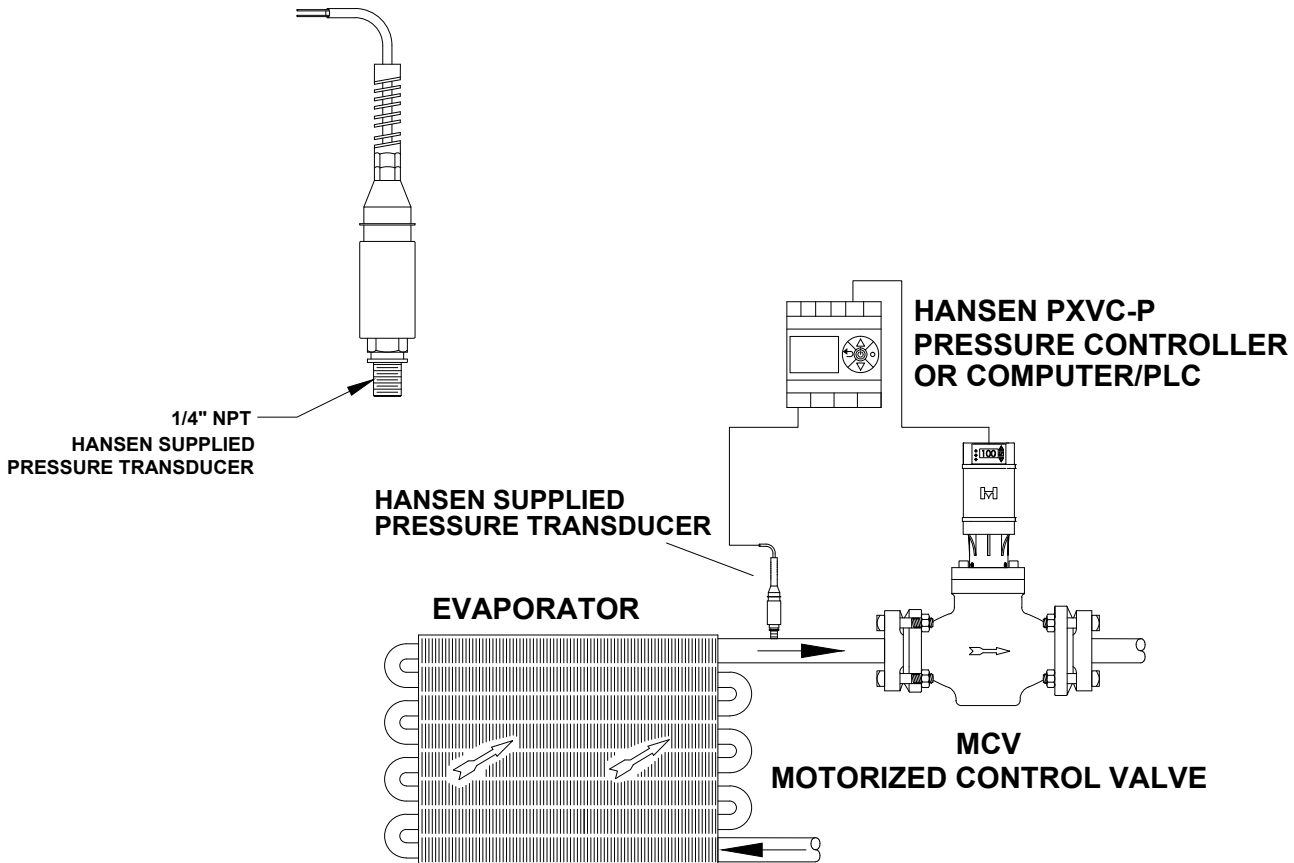

TYPICAL APPLICATIONS: MCV MOTORIZED CONTROL VALVE

TYPICAL CHILLER APPLICATIONS

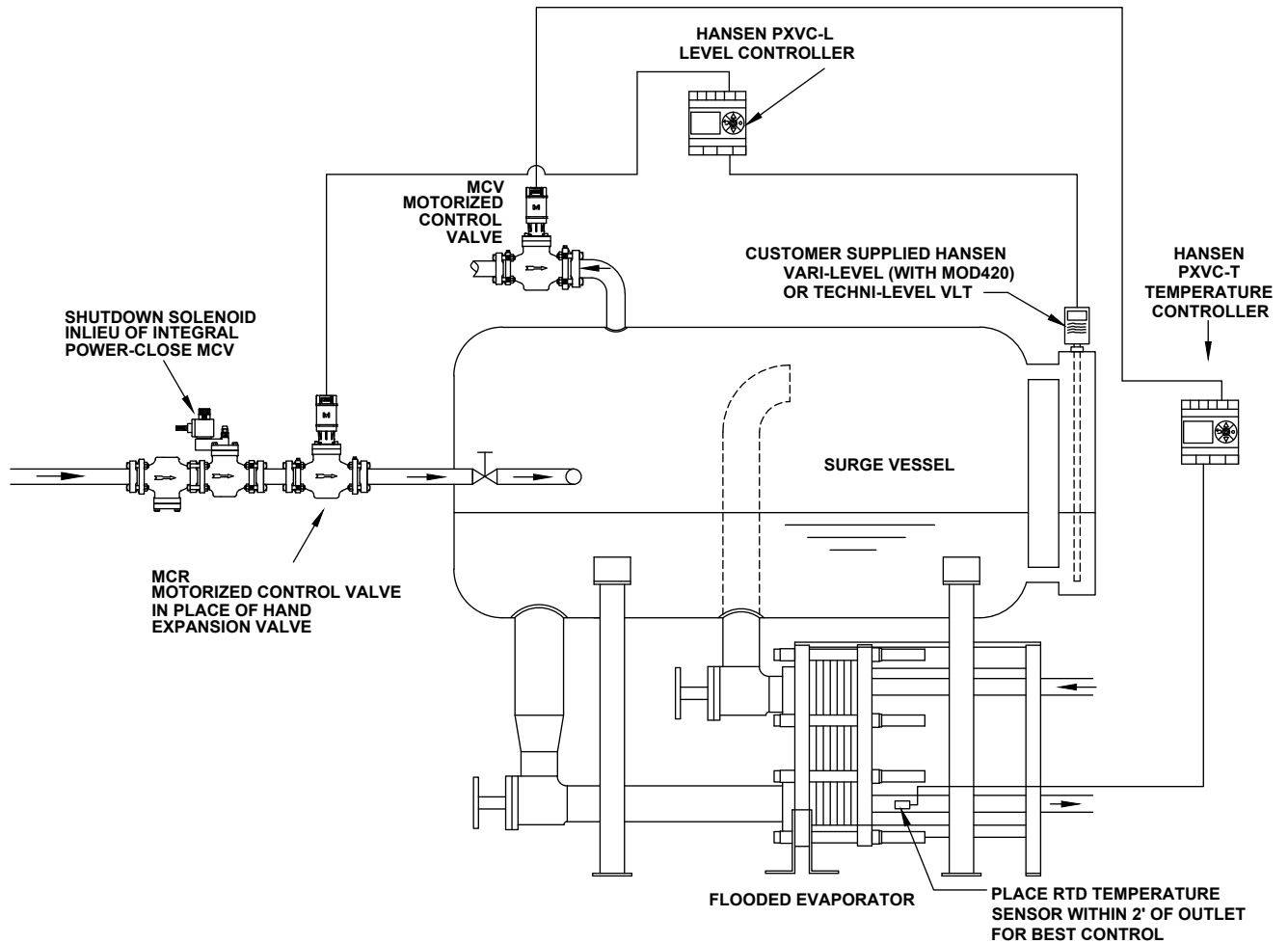

TYPICAL APPLICATIONS: MCV MOTORIZED CONTROL VALVE-SLOW OPENING AND CLOSING

SLOW OPENING AND CLOSING: SUCTION STOP VALVE

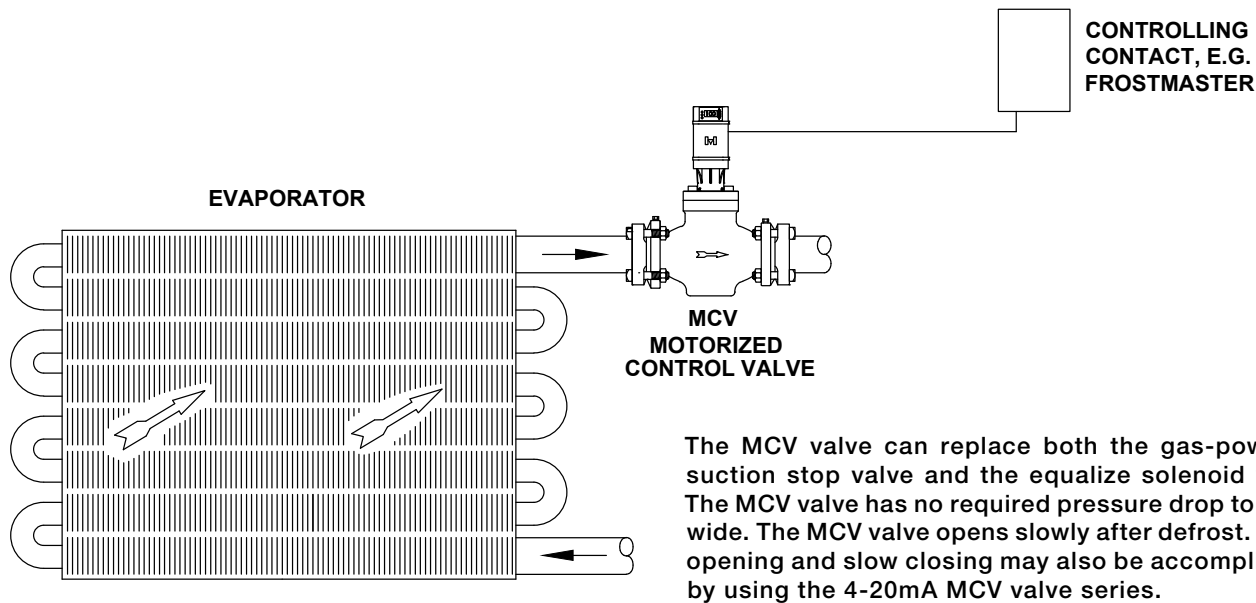

NO PRESSURE DROP REQUIRED: GRAVITY DRAIN

NO PRESSURE DROP: GRAVITY DRAIN

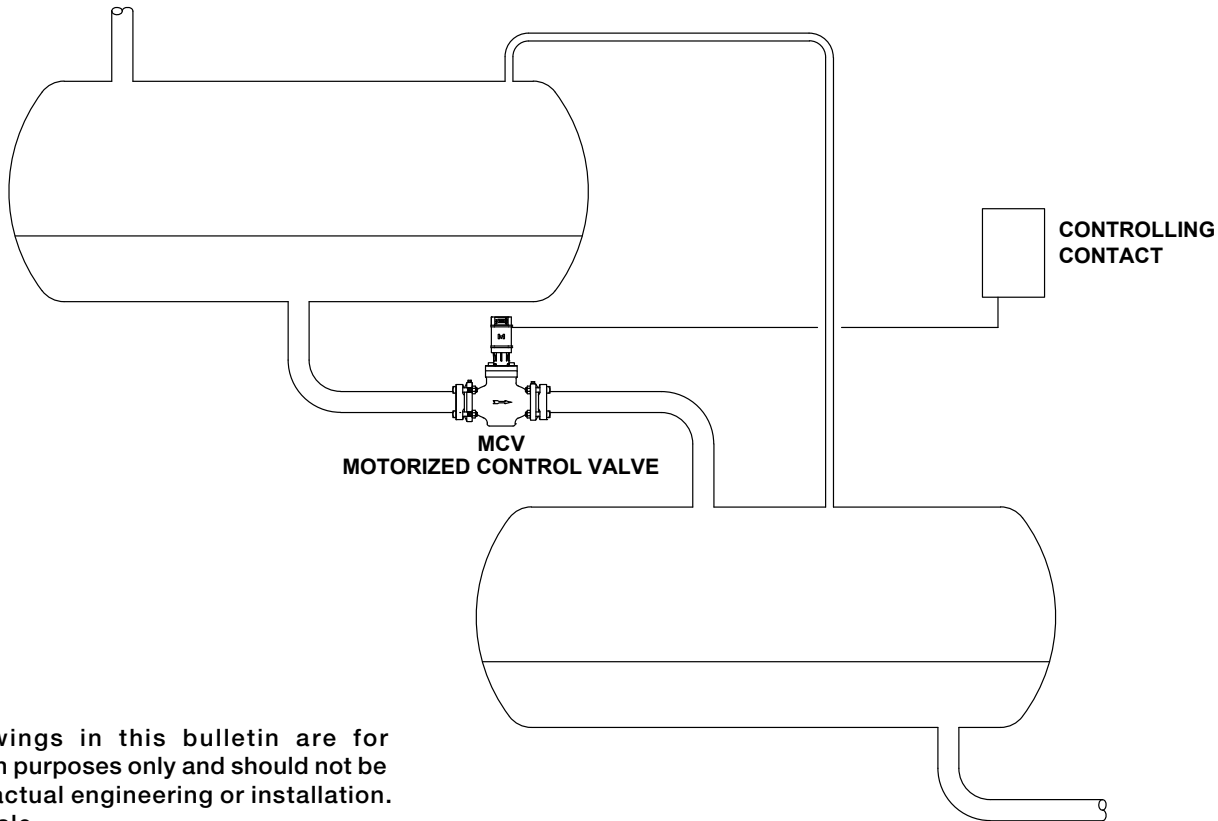

The drawings in this bulletin are for illustration purposes only and should not be used for actual engineering or installation. Not to scale.

Applications shown use Hansen supplied controllers, however, the Hansen MCV valve series can be integrated into most customer control systems.

MCR AND MCV SUCTION VAPOR CAPACITIES

AMMONIA SUCTION VAPOR CAPACITIES, TONS

Evap. Temp.	Pressure Drop	3/4"		1"		1-1/4"		1-1/2"		2"	
		MCR	MCV	MCR	MCV	MCR	MCV	MCR	MCV	MCR	MCV
°F	(psi)										
40	.25	1.5	4.2	2.7	8.0	3.7	11	8.2	24	11	32
	.50	2.1	6.0	3.7	11	5.4	16	12	34	15	45
	1.0	2.9	8.5	5.3	16	7.4	22	16	48	22	64
	2.0	4.1	12.0	7.3	22	10	31	23	67	31	90
	5	6.5	19	12	35	16	49	36	106	48	142
	10	9.2	27	16	49	23	69	51	150	69	201
	15	11.3	33	20	60	28	85	63	183	84	246
	20	13.0	38	23	70	33	98	73	212	97	285
0	.25	1.0	2.8	1.7	5.1	2.4	7.1	5.1	15	6.8	20
	.50	1.3	3.9	2.4	7.1	3.4	10	7.2	21	9.9	29
	1.0	1.9	5.5	3.3	10	4.7	14	10	30	14	40
	2.0	2.6	7.6	4.7	14	6.7	20	14	42	19	56
	5	4.1	12	7.4	22	11	32	23	66	30	89
	10	5.8	17	10	31	15	45	32	94	43	125
-40	.25	0.7	1.9	1.1	3.4	1.6	4.7	3.4	10	4.8	14
	.50	0.9	2.6	1.6	4.7	2.2	6.6	4.8	14	6.5	19
	1.0	1.2	3.6	2.2	6.5	3.1	9.2	6.9	20	8.9	26
	2.0	1.7	4.8	2.9	8.8	4.0	12	8.9	26	12	36
Cv		2.2	6.4	3.9	11.7	5.5	16.4	12	35	16	47

AMMONIA SUCTION VAPOR CAPACITIES, KILOWATTS

Evap. Temp.	Pressure Drop	20 MM		25 MM		32 MM		40 MM		50 MM	
		MCR	MCV	MCR	MCV	MCR	MCV	MCR	MCV	MCR	MCV
°C	(bar)										
5	.02	5.4	16	10	30	14	42	30	90	41	123
	.04	7.6	23	14	42	20	59	43	128	58	175
	.08	11	33	20	60	28	84	60	180	82	247
	.15	15	45	27	82	39	115	82	247	112	338
	.4	24	73	44	134	63	188	134	403	184	552
	.6	29	90	54	164	77	230	165	494	225	676
	1.0	38	116	70	212	100	297	213	638	290	873
	1.4	45	137	83	251	118	351	252	755	343	1,033
-20	.02	3.1	9.5	5.8	18	8.2	24	18	53	23	70
	.04	4.4	13	8.2	25	12	35	25	74	33	99
	.08	6.2	19	12	35	16	49	35	105	47	140
	.15	8.5	26	16	48	22	67	48	144	64	192
	.4	13.9	42	26	78	37	109	78	235	104	314
	.6	17.0	52	32	96	45	134	96	288	128	384
-40	.02	2.2	7	3.9	12	5.5	16	11	34	16	47
	.04	3.0	9	5.5	17	8	23	16	49	22	67
	.08	4.3	13	8	23	11	33	23	69	32	95
	.15	5.9	18	11	32	15	45	31	94	43	130
Kv		1.8	5.5	3.3	10	4.7	14	10	30	13.3	40

Reduced Capacity V-Ports shown in gray.

For best control and modulation, size the MCV valve for both the full load capacity and the minimum load capacity (weekend load). The minimum load capacity should be at least 15% of the full load capacity. The capacity tables are conservative, so it is not necessary to add a safety factor for capacity.

Ammonia, R-22 and R-134a capacities assume 86°F (30°C) condensing, except -40°F (-40°C) assumes +20°F (-7°C) liquid (e.g. two stage). R-404 and R-507 assume 95°F (35°C) condensing. For overfeed evaporator suction, add 20% to the evaporator load or use next larger size valve to accommodate liquid volume.

MCR AND MCV SUCTION VAPOR CAPACITIES

R-22 SUCTION VAPOR CAPACITIES, TONS

Evap. Temp.	Pressure Drop	3/4"		1"		1-1/4"		1-1/2"		2"	
		MCR	MCV	MCR	MCV	MCR	MCV	MCR	MCV	MCR	MCV
°F	(psi)										
40	.25	0.5	1.6	1.0	2.9	1.4	4.2	3.0	8.8	4.0	12
	.50	0.8	2.3	1.4	4.1	2.0	6.0	4.3	13	5.6	17
	1.0	1.1	3.2	1.9	5.8	2.8	8.5	6.1	18	7.9	23
	2.0	1.5	4.5	2.7	8.2	4.0	12	8.6	25	11	33
	5	2.4	7.1	4.3	13	6.4	19	14	40	18	52
	10	3.5	10	6.1	18	9.0	27	19	56	25	74
	15	4.2	12	7.5	22	11	33	23	68	31	90
20	4.9	14	8.6	26	13	38	27	79	36	104	
0	.25	0.3	1.0	0.6	1.8	0.9	2.6	1.8	5.3	2.5	7.4
	.50	0.5	1.4	0.9	2.6	1.2	3.7	2.6	7.5	3.6	11
	1.0	0.7	2.0	1.2	3.7	1.7	5.2	3.6	11	5.1	15
	2.0	1.0	2.8	1.7	5.2	2.4	7.3	5.1	15	7.1	21
	5	1.5	4.4	2.7	8.2	3.9	12	8.1	24	11	33
	10	2.2	6.3	3.9	12	5.5	16	11	34	16	47
-40	.25	0.3	0.8	0.5	1.4	0.7	2.0	1.5	4.2	1.9	5.7
	.50	0.4	1.1	0.7	2.0	0.9	2.8	2.1	6.0	2.7	8.0
	1.0	0.5	1.6	0.9	2.8	1.3	4.0	2.9	8.5	3.9	11
	2.0	0.8	2.2	1.3	4.0	1.9	5.6	4.1	12	5.4	16
Cv		2.2	6.4	3.9	11.7	5.5	16.4	12	35	16	47

US

R-22 SUCTION VAPOR CAPACITIES, KILOWATTS

Evap. Temp.	Pressure Drop	20 MM		25 MM		32 MM		40 MM		50 MM	
		MCR	MCV	MCR	MCV	MCR	MCV	MCR	MCV	MCR	MCV
°C	(bar)										
5	.02	2.2	7	4	12	6	17	11	34	16	49
	.04	3.0	9	6	17	8	24	16	48	23	69
	.08	4	13	8	24	11	34	22	67	33	98
	.15	6	18	11	33	15	46	31	92	45	134
	.4	10	29	18	54	25	75	50	150	73	219
	.6	12	36	22	66	31	92	61	184	89	268
	1.0	15	46	28	85	40	119	79	238	115	346
1.4	18	55	33	101	47	141	94	281	136	409	
-20	.02	1.3	4.0	2.3	7	3.3	10	7	21	10	29
	.04	1.9	6	3.2	10	5	14	10	30	14	41
	.08	2.6	8	5	14	7	20	14	42	19	58
	.15	3.6	11	6	19	9	27	19	58	27	80
	.4	5.9	18	10	31	15	44	32	95	43	131
	.6	7.2	22	13	38	18	54	39	116	53	160
-40	.02	1.0	3	1.8	5	2.6	8	5	16	7.0	22
	.04	1.4	4	2.6	8	4	11	8	23	10	32
	.08	1.9	6	4	11	5	15	11	32	15	45
	.15	2.6	8	5	15	7	21	15	44	20	61
Kv		1.8	5.5	3.3	10	4.7	14	10	30	13.3	40

METRIC

Reduced Capacity V-Ports shown in gray.

For best control and modulation, size the MCV valve for both the full load capacity and the minimum load capacity (weekend load). The minimum load capacity should be at least 15% of the full load capacity. The capacity tables are conservative, so it is not necessary to add a safety factor for capacity.

Ammonia, R-22 and R-134a capacities assume 86°F (30°C) condensing, except -40°F (-40°C) assumes +20°F (-7°C) liquid (e.g. two stage). R-404 and R-507 assume 95°F (35°C) condensing. For overfeed evaporator suction, add 20% to the evaporator load or use next larger size valve to accommodate liquid volume.

MCR AND MCV SUCTION VAPOR CAPACITIES

R-134a SUCTION VAPOR CAPACITIES, TONS

Evap. Temp.	Pressure Drop	3/4"		1"		1-1/4"		1-1/2"		2"	
		MCR	MCV	MCR	MCV	MCR	MCV	MCR	MCV	MCR	MCV
40	.25	0.4	1.3	0.8	2.3	1.1	3.2	2.3	6.7	3.1	9.2
	.50	0.6	1.8	1.1	3.3	1.5	4.6	3.3	10	4.4	13
	1.0	0.9	2.5	1.5	4.6	2.2	6.4	4.6	13	6.3	18
	2.0	1.2	3.6	2.2	6.5	3.1	9.1	6.5	19	8.9	26
	5	2.0	5.7	3.4	10	4.8	14	10	30	14	41
	10	2.8	8.0	4.8	15	6.8	20	15	42	20	58
	15	3.4	10	5.9	18	8.4	25	18	52	24	71
20	3.9	11	6.9	21	10	29	21	60	28	82	
0	.25	0.3	0.7	0.4	1.3	0.6	1.9	1.3	3.9	1.8	5.3
	.50	0.4	1.1	0.6	1.9	0.9	2.7	1.9	5.5	2.6	7.5
	1.0	0.5	1.5	0.9	2.7	1.3	3.7	2.7	7.8	3.6	11
	2.0	0.7	2.1	1.3	3.8	1.8	5.3	3.8	11	5.1	15
	5	1.1	3.3	2.0	6.0	2.8	8.4	6.0	17	8.1	24
	10	1.6	4.7	2.8	8.5	4.0	12	8.4	25	11	34
-40	.25	0.1	0.4	0.2	0.7	0.3	0.9	0.7	2.0	0.9	2.7
	.50	0.2	0.5	0.3	1.0	0.4	1.3	1.0	2.9	1.3	3.8
	1.0	0.2	0.7	0.4	1.3	0.6	1.8	1.4	4.0	1.8	5.4
	2.0	0.3	1.0	0.6	1.9	0.9	2.6	2.0	5.7	2.6	7.6
Cv		2.2	6.4	3.9	11.7	5.5	16.4	12	35	16	47

R-134a SUCTION VAPOR CAPACITIES, KILOWATTS

Evap. Temp.	Pressure Drop	20 MM		25 MM		32 MM		40 MM		50 MM	
		MCR	MCV	MCR	MCV	MCR	MCV	MCR	MCV	MCR	MCV
5	.02	1.7	5	3	9	4	13	9	27	13	38
	.04	2.4	7	4	13	6	18	13	39	18	53
	.08	3	10	6	18	9	26	18	55	25	75
	.15	5	14	8	25	12	35	25	75	34	103
	.4	7	23	13	41	19	57	41	122	56	168
	.6	9	28	17	50	24	70	50	150	68	206
	1.0	12	36	21	65	30	90	65	194	88	266
1.4	14	43	25	76	36	107	76	229	105	315	
-20	.02	0.9	2.7	1.7	5	2.3	7	5	15	7	20
	.04	1.3	4	2.4	7	3	10	7	21	10	29
	.08	1.8	5	3	10	5	14	10	30	14	41
	.15	2.5	7.5	5	14	6	19	14	41	19	56
	.4	4.0	12	8	23	10	31	22	67	30	91
	.6	4.9	15	9	28	13	38	27	82	37	112
-40	.02	0.5	1	0.8	3	1.2	4	3	8	4	11
	.04	0.7	2	1.2	4	2	5	4	11	5	15
	.08	1.0	3	2	5	2	7	5	16	7	22
	.15	1.3	4	2	7	3	10	7	22	10	30
Kv		1.8	5.5	3.3	10	4.7	14	10	30	13.3	40

Reduced Capacity V-Ports shown in gray.

For best control and modulation, size the MCV valve for both the full load capacity and the minimum load capacity (weekend load). The minimum load capacity should be at least 15% of the full load capacity. The capacity tables are conservative, so it is not necessary to add a safety factor for capacity.

Ammonia, R-22 and R-134a capacities assume 86°F (30°C) condensing, except -40°F (-40°C) assumes +20°F (-7°C) liquid (e.g. two stage). R-404 and R-507 assume 95°F (35°C) condensing. For overfeed evaporator suction, add 20% to the evaporator load or use next larger size valve to accommodate liquid volume.

MCR AND MCV SUCTION VAPOR CAPACITIES

R-404 SUCTION VAPOR CAPACITIES, TONS

Evap. Temp.	Pressure Drop	3/4"		1"		1-1/4"		1-1/2"		2"	
		MCR	MCV	MCR	MCV	MCR	MCV	MCR	MCV	MCR	MCV
40	.25	0.5	1.4	0.8	2.5	1.2	3.5	2.5	7.4	3.4	9.9
	.50	0.7	2.0	1.2	3.6	1.7	5.0	3.6	11	4.8	14
	1.0	0.9	2.8	1.7	5.0	2.4	7.1	5.1	15	6.7	20
	2.0	1.3	3.9	2.4	7.1	3.4	10	7.2	21	9.5	28
	5	2.1	6.2	3.7	11	5.3	16	11	33	15	44
	10	3.0	8.7	5.3	16	7.5	22	16	47	21	63
	15	3.7	11	6.5	19	9.2	27	20	58	26	77
20	4.2	12	7.5	22	11	32	23	66	30	89	
0	.25	0.3	0.8	0.5	1.4	0.7	2.1	1.5	4.2	2.0	6.0
	.50	0.4	1.2	0.7	2.1	1.0	2.9	2.1	6.0	2.9	8.5
	1.0	0.6	1.6	1.0	2.9	1.4	4.1	2.9	8.5	4.1	12
	2.0	0.8	2.3	1.4	4.1	1.9	5.8	4.1	12	5.8	17
	5	1.3	3.6	2.2	6.5	3.1	9.2	6.5	19	9.2	27
	10	1.8	5.1	3.1	9.2	4.3	13	9.2	27	13	38
-40	.25	0.1	0.4	0.3	0.8	0.4	1.1	0.8	2.3	1.1	3.1
	.50	0.2	0.6	0.4	1.1	0.5	1.6	1.1	3.3	1.5	4.5
	1.0	0.3	0.8	0.5	1.6	0.7	2.2	1.6	4.7	2.1	6.3
	2.0	0.4	1.2	0.7	2.2	1.0	3.1	2.3	6.6	3.0	8.9
Cv		2.2	6.4	3.9	11.7	5.5	16.4	12	35	16	47

R-404 SUCTION VAPOR CAPACITIES, KILOWATTS

Evap. Temp.	Pressure Drop	20 MM		25 MM		32 MM		40 MM		50 MM	
		MCR	MCV	MCR	MCV	MCR	MCV	MCR	MCV	MCR	MCV
5	.02	1.8	5.5	3.4	10	4.8	14	10	31	14	42
	.04	2.5	7.7	4.8	14	6.8	20	14	43	20	59
	.08	3.6	11	6.7	20	9.6	28	20	61	28	83
	.15	4.9	15	9.2	28	13	39	28	84	38	114
	.4	8.0	24	15	46	21	64	46	137	62	186
	.6	9.8	30	18	56	26	78	56	168	76	228
	1.0	13	39	24	72	34	101	72	217	98	294
	1.4	15	46	28	86	40	119	86	257	116	348
-20	.02	1.0	3.1	1.8	5.5	2.6	7.7	5.6	17	7.6	23
	.04	1.4	4.3	2.6	7.7	3.6	11	7.9	24	11	33
	.08	2.0	6.1	3.6	11	5.1	15	11	34	15	46
	.15	2.7	8.4	5.0	15	7.1	21	15	46	21	63
	.4	4.5	14	8.1	24	12	34	25	75	34	103
	.6	5.5	17	10	30	14	42	31	92	42	126
-40	.02	0.6	1.8	1.0	3.2	1.5	4.4	3.2	9.5	4.4	13
	.04	0.8	2.5	1.5	4.5	2.1	6.2	4.5	13	6.2	19
	.08	1.1	3.5	2	6.4	2.9	8.8	6.3	19	8.7	26
	.15	1.6	4.8	3	8.7	4.0	12	8.7	26	12	36
Kv		1.8	5.5	3.3	10	4.7	14	10	30	13.3	40

Reduced Capacity V-Ports shown in gray.

For best control and modulation, size the MCV valve for both the full load capacity and the minimum load capacity (weekend load). The minimum load capacity should be at least 15% of the full load capacity. The capacity tables are conservative, so it is not necessary to add a safety factor for capacity.

Ammonia, R-22 and R-134a capacities assume 86°F (30°C) condensing, except -40°F (-40°C) assumes +20°F (-7°C) liquid (e.g. two stage). R-404 and R-507 assume 95°F (35°C) condensing. For overfeed evaporator suction, add 20% to the evaporator load or use next larger size valve to accommodate liquid volume.

US

METRIC

MCR AND MCV SUCTION VAPOR CAPACITIES

R-507 SUCTION VAPOR CAPACITIES, TONS

Evap. Temp.	Pressure Drop	3/4"		1"		1-1/4"		1-1/2"		2"	
		MCR	MCV	MCR	MCV	MCR	MCV	MCR	MCV	MCR	MCV
°F	(psi)										
40	.25	0.5	1.4	0.9	2.6	1.2	3.5	2.7	7.8	3.5	10
	.50	0.7	2.0	1.2	3.7	1.7	5.0	3.8	11	4.9	15
	1.0	1.0	2.8	1.7	5.2	2.4	7.1	5.3	16	7.0	21
	2.0	1.4	4.0	2.4	7.3	3.4	10	7.5	22	9.9	29
	5	2.2	6.3	3.8	12	5.3	16	12	35	16	46
	10	3.1	8.9	5.4	16	7.5	22	17	49	22	65
	15	3.8	11	6.7	20	9.2	27	21	60	27	79
20	4.3	13	7.7	23	11	32	24	70	31	92	
0	.25	0.3	0.8	0.5	1.6	0.7	2.2	1.6	4.6	2.2	6.4
	.50	0.4	1.2	0.7	2.2	1.0	3.1	2.2	6.5	3.1	9.0
	1.0	0.6	1.7	1.0	3.1	1.4	4.3	3.2	9.2	4.3	13
	2.0	0.8	2.4	1.5	4.4	2.0	6.1	4.5	13	6.1	18
	5	1.3	3.8	2.3	7.0	3.2	9.6	7.0	21	9.7	28
	10	1.8	5.4	3.3	9.8	4.6	14	10	29	14	40
-40	.25	0.2	0.5	0.3	0.8	0.4	1.2	0.9	2.5	1.1	3.4
	.50	0.2	0.7	0.4	1.2	0.6	1.7	1.2	3.6	1.6	4.8
	1.0	0.3	0.9	0.6	1.7	0.8	2.3	1.7	5.0	2.3	6.7
	2.0	0.4	1.3	0.8	2.4	1.1	3.3	2.4	7.1	3.2	9.5
Cv		2.2	6.4	3.9	11.7	5.5	16.4	12	35	16	47

R-507 SUCTION VAPOR CAPACITIES, KILOWATTS

Evap. Temp.	Pressure Drop	20 MM		25 MM		32 MM		40 MM		50 MM	
		MCR	MCV	MCR	MCV	MCR	MCV	MCR	MCV	MCR	MCV
°C	(bar)										
5	.02	1.9	5.8	3.5	11	4.9	15	11	32	14	43
	.04	2.7	8.3	4.9	15	6.9	21	15	45	20	61
	.08	3.8	12	7.0	21	9.8	29	21	64	29	87
	.15	5.2	16	9.6	29	13	40	29	87	40	119
	.4	8.6	26	16	47	22	65	47	142	65	194
	.6	10	32	19	58	27	80	58	174	79	238
	1.0	14	41	25	75	35	103	75	225	102	307
1.4	16	49	29	89	41	122	89	266	121	364	
-20	.02	1.1	3.2	1.9	5.8	2.8	8.4	6.0	18	8.0	24
	.04	1.5	4.6	2.7	8.3	4.0	12	8.4	25	11	34
	.08	2.1	6.5	3.9	12	5.6	17	12	36	16	48
	.15	2.9	8.9	5.3	16	7.7	23	16	49	22	66
	.4	4.8	15	8.6	26	13	38	27	80	36	108
	.6	5.8	18	11	32	15	46	33	98	44	132
-40	.02	0.6	1.9	1.1	3.4	1.6	4.7	3.4	10	4.6	14
	.04	0.9	2.6	1.6	4.8	2.3	6.7	4.8	14	6.5	20
	.08	1.2	3.7	2.2	6.8	3.2	9.5	6.8	20	9.2	28
	.15	1.7	5.1	3.1	9.3	4.4	13	9.3	28	13	38
Kv		1.8	5.5	3.3	10	4.7	14	10	30	13.3	40

Reduced Capacity V-Ports shown in gray.

For best control and modulation, size the MCV valve for both the full load capacity and the minimum load capacity (weekend load). The minimum load capacity should be at least 15% of the full load capacity. The capacity tables are conservative, so it is not necessary to add a safety factor for capacity.

Ammonia, R-22 and R-134a capacities assume 86°F (30°C) condensing, except -40°F (-40°C) assumes +20°F (-7°C) liquid (e.g. two stage). R-404 and R-507 assume 95°F (35°C) condensing. For overfeed evaporator suction, add 20% to the evaporator load or use next larger size valve to accommodate liquid volume.

MCR AND MCV LIQUID MAKE-UP AND DIRECT EXPANSION CAPACITIES

US TONS

Port Size (IN)	Model No.	Recommended Minimum Line Size (inches)		Cv	Capacity Range, Tons									
					Ammonia		R-22		R-134a		R-404		R-507	
		Ammonia	Halocarbon		High to Intermediate	Intermediate to Low	High to Intermediate	Intermediate to Low	High to Intermediate	Intermediate to Low	High to Intermediate	Intermediate to Low	High to Intermediate	Intermediate to Low
3/4"	MCR	1-1/2"	1-1/2"	2.2	266	155	54	37	41	28	39	31	38	30
1"	MCR	2"	2"	3.9	472	274	97	65	73	49	68	55	67	53
1-1/4"	MCR	2-1/2"	2-1/2"	5.5	666	387	136	92	104	69	97	77	95	74
1-1/2"	MCRB	2-1/2"	3"	6.0	726	422	149	100	113	76	105	84	104	81
1-1/2"	MCR	4"	4"	12	1,453	844	297	200	226	151	211	168	207	163
2"	MCR	4"	4"	16	1,937	1,125	396	267	301	202	281	224	277	217

US

METRIC KILOWATTS

Port Size (mm)	Model No.	Recommended Minimum Line Size (mm)		Kv	Capacity Range, kW									
					Ammonia		R-22		R-134a		R-404		R-507	
		Ammonia	Halocarbon		High to Intermediate	Intermediate to Low	High to Intermediate	Intermediate to Low	High to Intermediate	Intermediate to Low	High to Intermediate	Intermediate to Low	High to Intermediate	Intermediate to Low
20	MCR	40	40	1.8	936	545	190	130	144	98	137	109	134	106
25	MCR	50	50	3.3	1660	964	341	229	257	172	239	193	236	186
32	MCR	65	65	4.7	2342	1361	478	324	366	243	341	271	334	260
40	MCRB	65	75	5.0	2553	1484	524	352	397	267	369	295	366	285
40	MCR	100	100	10.0	5110	2968	1045	703	795	531	742	591	728	573
50	MCR	100	100	13.3	6812	3957	1393	939	1059	710	988	788	974	763

METRIC

Ammonia line size capacities are based on IIAR Refrigeration Piping Handbook tables. Halocarbon line size capacities are based on a nominal 3 ft/sec liquid velocity.

For applications with a large pressure drop across the Motorized Control Valve, attention must be paid to proper outlet line sizing to accommodate flash gas.

Ammonia, R-22 and R134a capacities are based on +86°F (+30°C) saturated liquid and +20°F(-10°C) evaporating temperature, and intermediate to low capacity based on +20°F (-10°C) saturation temperature and -20°F (-30°C) evaporating temperature. Capacities are with ±20% from -40°F (-40°C) to -0°F (-18°C). R404 and R507 capacities based on +95° F (+35°C) condensing temperature.

MCR AND MCV HIGH PRESSURE LIQUID LINE CAPACITIES

AMMONIA HIGH PRESSURE LIQUID LINE CAPACITIES, TONS

Pressure Drop psi	Nominal Size (INCHES)									
	3/4"		1"		1-1/4"		1-1/2"		2"	
	MCR	MCV	MCR	MCV	MCR	MCV	MCR	MCV	HCM	MCV
1.0	34	98	60	180	85	254	185	539	246	723
2.0	48	139	85	255	120	359	261	762	348	1,023
Cv	2.2	6.4	3.9	11.7	5.5	16.4	12	35	16	47

AMMONIA HIGH PRESSURE LIQUID LINE CAPACITIES, KILOWATTS

Pressure Drop bar	Nominal Size (MM)									
	20		25		32		40		50	
	MCR	MCV	MCR	MCV	MCR	MCV	MCR	MCV	HCM	MCV
0.10	139	425	255	773	363	1,082	773	2,318	1,053	3,168
0.20	197	601	361	1,093	514	1,530	1,093	3,278	1,490	4,480
kv	1.8	5.5	3.3	10	4.7	14	10	30	13.3	40

R-22 HIGH PRESSURE LIQUID LINE CAPACITIES, TONS

Pressure Drop psi	Nominal Size (INCHES)									
	3/4"		1"		1-1/4"		1-1/2"		2"	
	MCR	MCV	MCR	MCV	MCR	MCV	MCR	MCV	HCM	MCV
1.0	7.0	21	12	37	18	53	39	113	52	151
2.0	10	29	18	53	25	75	55	160	73	214
Cv	2.2	6.4	3.9	11.7	5.5	16.4	12	35	16	47

R-22 HIGH PRESSURE LIQUID LINE CAPACITIES, KILOWATTS

Pressure Drop bar	Nominal Size (MM)									
	20		25		32		40		50	
	MCR	MCV	MCR	MCV	MCR	MCV	MCR	MCV	HCM	MCV
0.10	30	91	54	164	77	230	164	493	218	657
0.20	42	128	77	232	109	325	232	697	309	929
kv	1.8	5.5	3.3	10	4.7	14	10	30	13.3	40

Ammonia, R-22, and R-134a capacities based on +86°F(30°C) saturated liquid, and +20°F (-10°C) evaporator, and no flashing through the valve. R-404 and R-507 based on 95°F(35°C) saturated liquid temperatures.

Refer to page 2 for Liquid Line Sizing. Liquid line based on IAR Piping Handbook Line Size Capacities.

MCR AND MCV HIGH PRESSURE LIQUID LINE CAPACITIES

R-134a HIGH PRESSURE LIQUID LINE CAPACITIES, TONS

Pressure Drop psi	Nominal Size (INCHES)									
	3/4"		1"		1-1/4"		1-1/2"		2"	
	MCR	MCV	MCR	MCV	MCR	MCV	MCR	MCV	HCM	MCV
1.0	7.0	19	12	35	16	49	36	104	47	139
2.0	9.0	27	16	49	23	69	50	147	67	197
Cv	2.2	6.4	3.9	11.7	5.5	16.4	12	35	16	47

R-134a HIGH PRESSURE LIQUID LINE CAPACITIES, KILOWATTS

Pressure Drop bar	Nominal Size (MM)									
	20		25		32		40		50	
	MCR	MCV	MCR	MCV	MCR	MCV	MCR	MCV	HCM	MCV
0.10	27	83	50	152	71	213	152	456	202	607
0.20	39	118	71	215	101	301	215	645	286	859
kv	1.8	5.5	3.3	10	4.7	14	10	30	13.3	40

R-404 HIGH PRESSURE LIQUID LINE CAPACITIES, TONS

Pressure Drop psi	Nominal Size (INCHES)									
	3/4"		1"		1-1/4"		1-1/2"		2"	
	MCR	MCV	MCR	MCV	MCR	MCV	MCR	MCV	HCM	MCV
1.0	4.0	13	8.0	23	11	33	24	69	32	93
2.0	6.0	18	11	33	15	46	33	97	45	131
Cv	2.2	6.4	3.9	11.7	5.5	16.4	12	35	16	47

R-404 HIGH PRESSURE LIQUID LINE CAPACITIES, KILOWATTS

Pressure Drop bar	Nominal Size (MM)									
	20		25		32		40		50	
	MCR	MCV	MCR	MCV	MCR	MCV	MCR	MCV	HCM	MCV
0.10	19	57	34	103	48	144	103	310	141	423
0.20	26	80	48	146	68	204	146	438	199	598
kv	1.8	5.5	3.3	10	4.7	14	10	30	13.3	40

R-507 HIGH PRESSURE LIQUID LINE CAPACITIES, TONS

Pressure Drop psi	Nominal Size (INCHES)									
	3/4"		1"		1-1/4"		1-1/2"		2"	
	MCR	MCV	MCR	MCV	MCR	MCV	MCR	MCV	HCM	MCV
1.0	4.0	13	8.0	23	11	33	24	69	32	93
2.0	6.0	18	11	33	15	46	33	97	45	131
Cv	2.2	6.4	3.9	11.7	5.5	16.4	12	35	16	47

R-507 HIGH PRESSURE LIQUID LINE CAPACITIES, KILOWATTS

Pressure Drop bar	Nominal Size (MM)									
	20		25		32		40		50	
	MCR	MCV	MCR	MCV	MCR	MCV	MCR	MCV	HCM	MCV
0.10	19	57	34	104	49	145	104	311	142	426
0.20	27	81	49	147	69	205	147	440	200	602
kv	1.8	5.5	3.3	10	4.7	14	10	30	13.3	40

Ammonia, R-22, and R-134a capacities based on +86°F(30°C) saturated liquid, and +20°F (-10°C) evaporator, and no flashing through the valve. R-404 and R-507 based on 95°F(35°C) saturated liquid temperatures.

Refer to page 2 for Liquid Line Sizing. Liquid line based on IIAR Piping Handbook Line Size Capacities.

MCR AND MCV HOT GAS SOLENOID DEFROST CAPACITIES
EVAPORATOR SIZE IN TONS (kW)

Refrigerant	Nominal Size (MM)				
	3/4" (20)	1" (25)	1-1/4" (32)	1-1/2" (40)	2" (50)
Ammonia	9-15 (32-53)	15-28 (53-99)	28-39 (99-137)	39-73 (137-256)	73-106 (256-373)
R-22	6-8 (21-28)	8-15 (28-53)	15-20 (53-70)	20-32 (70-113)	32-47 (113-165)
R-134a	1-4 (4-14)	4-8 (14-28)	8-12 (28-42)	12-20 (42-70)	20-38 (70-134)
R-404	3-6 (11-22)	6-10 (22-35)	10-18 (35-63)	18-30 (63-106)	30-44 (106-155)
R-507	1-4 (4-14)	4-8 (14-28)	8-12 (28-42)	12-20 (42-70)	20-38 (70-134)

Evaporator tons at 10°F temperature differential, valve capacities are conservative.

OPERATION

The valve is driven by a motor and electronics that are placed inside of an IP67 watertight rated housing. Upon receiving an input signal, the motor shaft rotates and transfers the force via a magnetic coupling to a threaded stem. This cartridge stem directly drives the valve V-port to open or closed based on the incoming signal.

The actuator can run on incoming voltage of either 24VAC or 24VDC. This is provided via two wires on the 5 pin connector. Upon power-up the valve will run through a self-calibration process. The actuator can be configured into 1 of 2 operational modes: modulating or slow/open close based on the wiring of the 8 pin connector along with the menu selection. There are 2 additional wires on the 8 pin connector that provide 0/4-20mA feedback of the valve V-port position. The feedback does not have to be connected to operate the valve.

To operate in the modulating mode, a milliamp or voltage input control signal must always be maintained to keep the V-port in position. A loss of signal or a signal out of range will drive the valve closed and display an error code. When the signal is present, the V-port will move and stay at that location until the input signal changes. If loss of input power occurs, the valve remains in its current position, unless the valve is equipped with Power Backup system.

To operate in the slow open/close solenoid mode, a relay contact is required as a means of an input signal to fully open or close the valve. No external voltage is needed to power the relay signal. As a default, when the relay is closed the valve is closed. A loss of signal will drive the valve closed. If loss of input power occurs, the valve remains in its current position, unless the valve is equipped with Power Backup system.

ELECTRICAL INFORMATION & WIRING

The Motorized Control Valve will take either a 24VAC or 24VDC input voltage from an NEC Class 2 source and either a voltage, current, or relay input control signal. It is recommended to use a separate power supply from the main supply for the current and voltage input signal to maintain signal integrity. A dedicated incoming voltage supply must be sized properly to deliver the proper amount of voltage and current to powerhead. A transformer rated at 24VA per valve or a power supply rated at .8A per valve will be sufficient.

The incoming control signal can be wired and configured as any of the following: 4-20mA, 0-20mA, 0-5VDC, 0-10VDC, 1-6VDC, and a relay closed contact. The output feedback signal of the valve position can be configured as 4-20mA or 0-20mA.

ELECTRICAL MAINTENANCE

Check calibration and Power Backup function on a routine basis. Check controller and controller wiring for corrosion and proper connection.

CABLE CONNECTIONS

There are 2 distinct connection points that reside on the MCV powerhead. Both are M12 male connectors. The power input consists of a 5 pin keyed connector and the control signal consists of an 8 pin keyed connector.

The MCV comes standard with 6.5ft (2m) long cables with M12 female heads. The power input cable consists of a 5 pin head and 22AWG wires. The control signal consists of an 8 pin head and 24AWG wires. The standard cables come with flying leads. When an SMV to MCV conversion kit is purchased for a modulating valve, the cable dangle will come equipped a connection that will plug into to existing wiring.

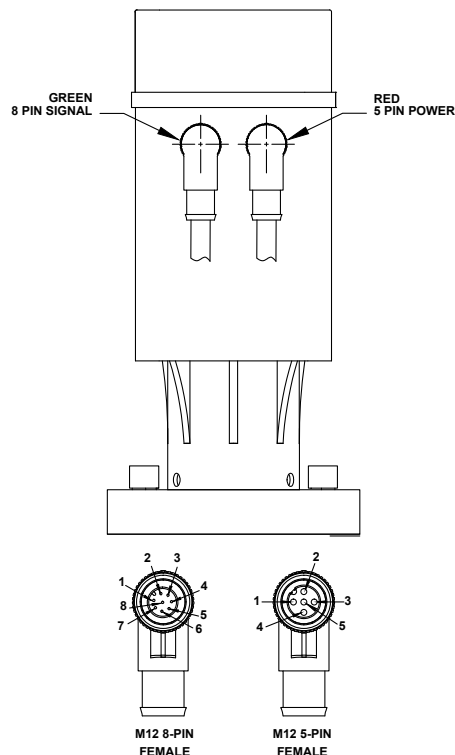

Power Connector - 5 Pin Red Cable

Pin #	Wire Color	Description
1	Brown	Not Used
2	White	Not Used
3	Blue	(+) Backup Power Supply
4	Black	(+) 24VDC/24VAC
5	Gray	(-) 24VDC/24VAC

Signal Connector - 8 Pin Green Cable

Pin #	Wire Color	Description
1	White	Not Used
2	Brown	(-) 4-20mA Feedback Signal
3	Green	(+) 4-20mA Feedback Signal
4	Yellow	(-) Input Signal/Ground
5	Gray	(+) 0/4-20mA Input Signal
6	Pink	(+) 0-5/10VDC & Relay Input Signal
7	Blue	Not Used
8	Red	Not Used

MOTORIZED CONTROL VALVE WIRING DIAGRAM

CUSTOMER SUPPLIED POWER SUPPLY AND CONTROLLER

(Current Input Modulating Control with Position Feedback)

The valve is supplied with 6.5 feet of cable with 22 and 24 gauge wires. For greater distance between valve and controller use wire size as shown in Table 1: 24VAC/DC Power Wiring. Do not run Motorized Control Valve wiring with or near high voltage power wiring or VFD Controls (Variable Frequency Drives). Do not earth or ground 24 VAC wiring.

CURRENT INPUT MODULATING SIGNAL WIRING DIAGRAM

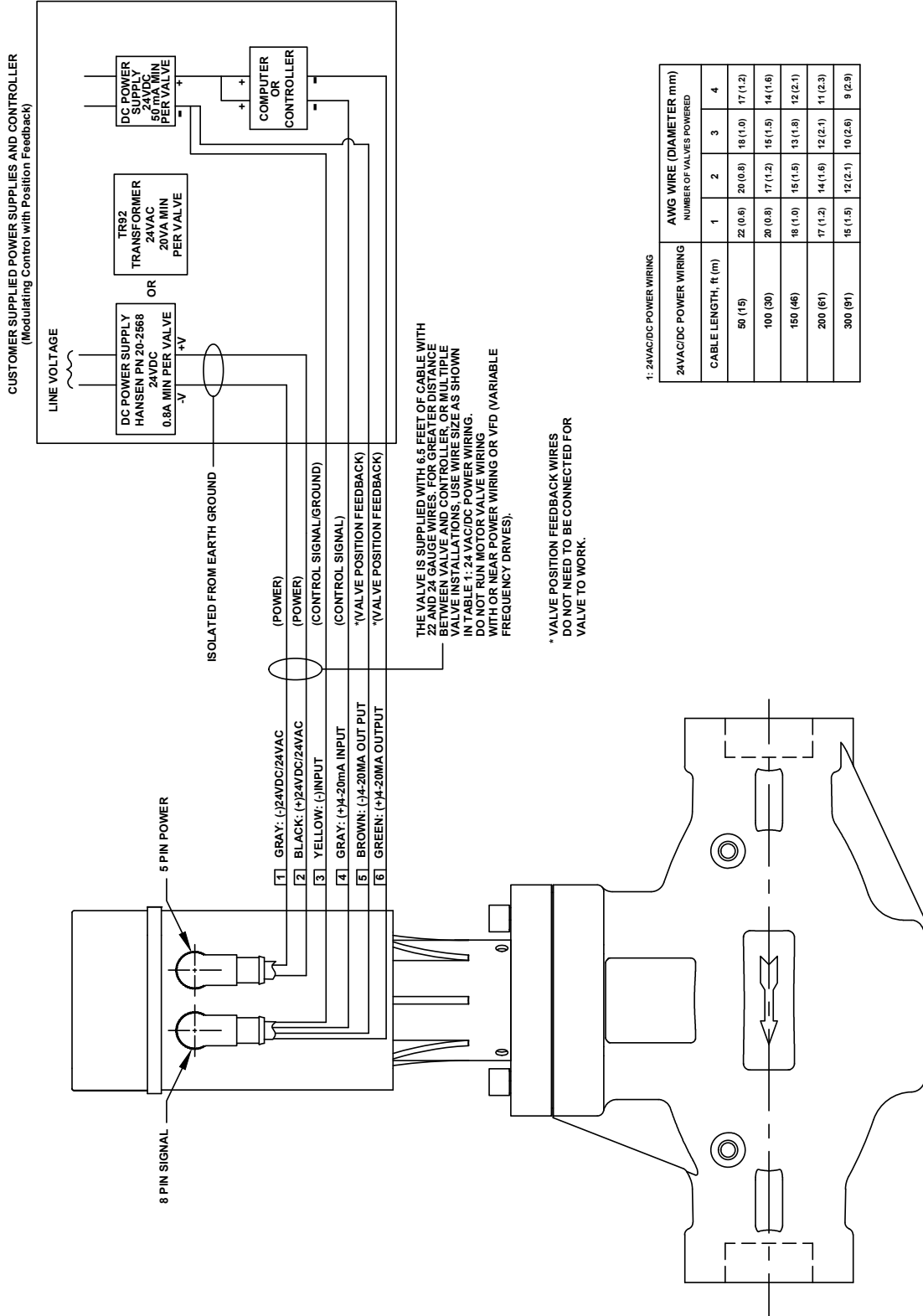

MOTORIZED CONTROL VALVE WIRING DIAGRAM

CUSTOMER SUPPLIED POWER SUPPLY AND CONTROLLER

(Voltage Input Modulating Control with Position Feedback)

The valve is supplied with 6.5 feet of cable with 22 and 24 gauge wires. For greater distance between valve and controller use wire size as shown in Table 1: 24VAC/DC Power Wiring. Do not run Motorized Control Valve wiring with or near high voltage power wiring or VFD Controls (Variable Frequency Drives). Do not earth or ground 24 VAC wiring.

VOLTAGE INPUT MODULATING SIGNAL WIRING DIAGRAM

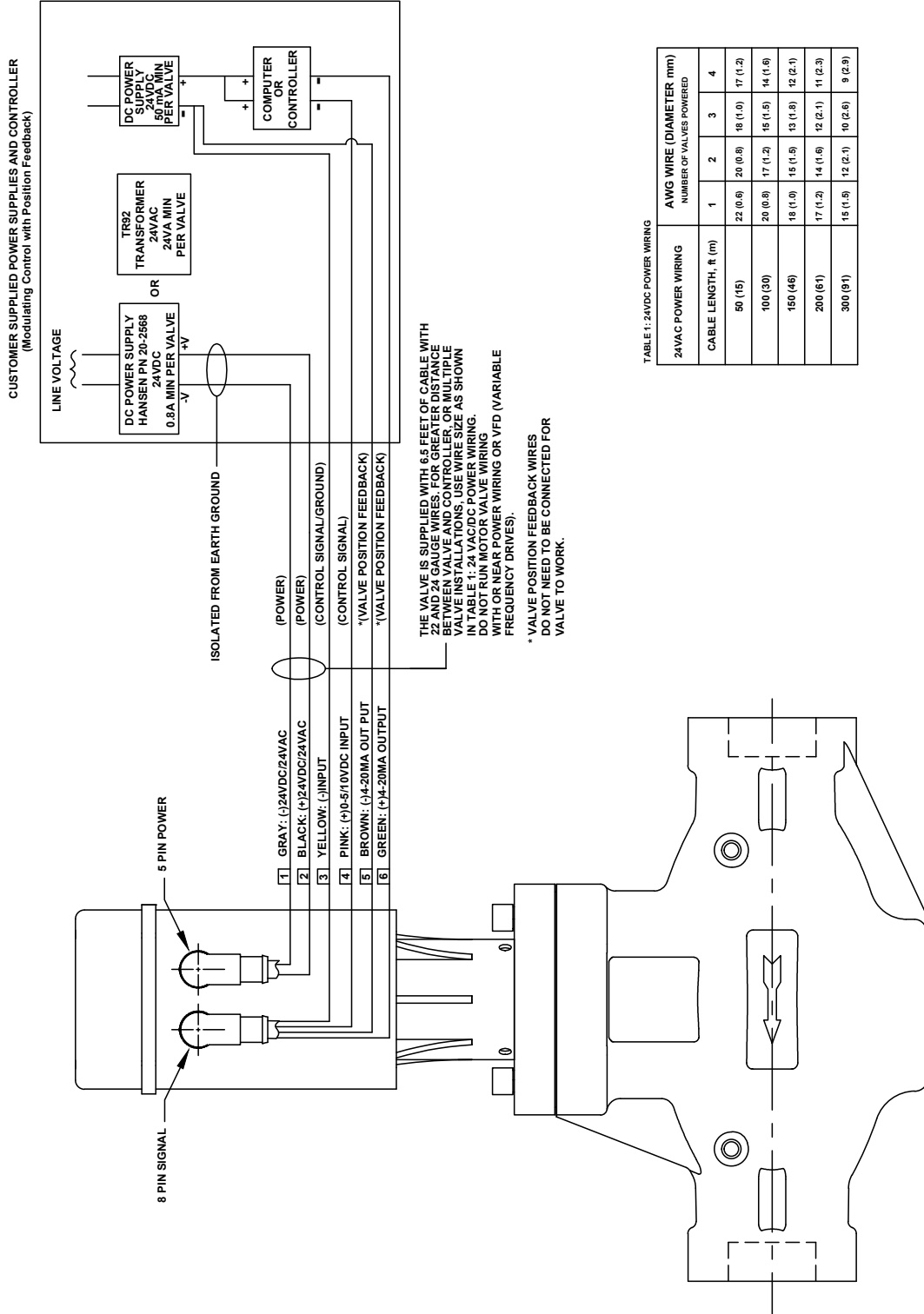

MOTORIZED CONTROL VALVE WIRING DIAGRAM

CUSTOMER SUPPLIED POWER SUPPLY AND CONTROLLER

(Relay Input Slow Open/Close Solenoid Control)

The valve is supplied with 6.5 feet of cable with 22 and 24 gauge wires. For greater distance between valve and controller use wire size as shown in Table 1: 24VAC/DC Power Wiring. Do not run Motorized Control Valve wiring with or near high voltage power wiring or VFD Controls (Variable Frequency Drives). Do not earth or ground 24 VAC wiring.

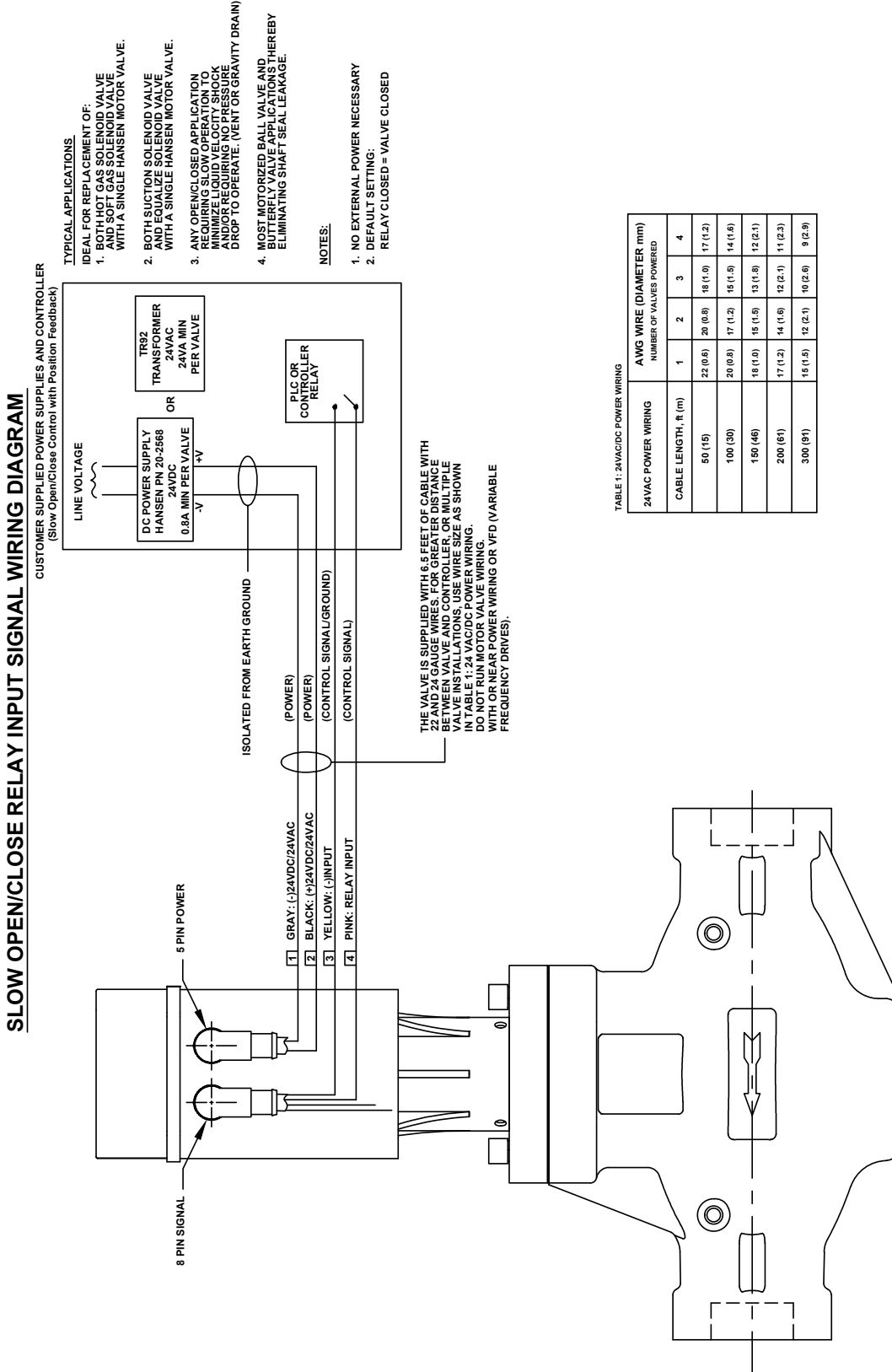

POWER BACKUP SYSTEM

The Motorized Control Valve can be wired to an optional power backup system that will control the valve to a user defined location upon a loss of the incoming voltage. These locations of fully open, fully closed, or another open position can all be programmed through the user interface display. The Uninterruptable Power Supply (UPS) consists of a voltage monitoring system as well as an integrated battery.

The optional UPS when combined with an appropriately sized DC power supply can run up to 3 Motorized Control Valves. If the incoming line voltage drops below 19 volts and the power backup system is active, the system will switch over to use the battery power. This UPS mode is indicated by a slow flashing green LED as seen on the diagram below. The RED will illuminate when there is an issue or the battery needs to be replaced. Once the incoming voltage level is restored, the valve will automatically return to normal control mode.

UPS LED Mode Indicator - Green LED

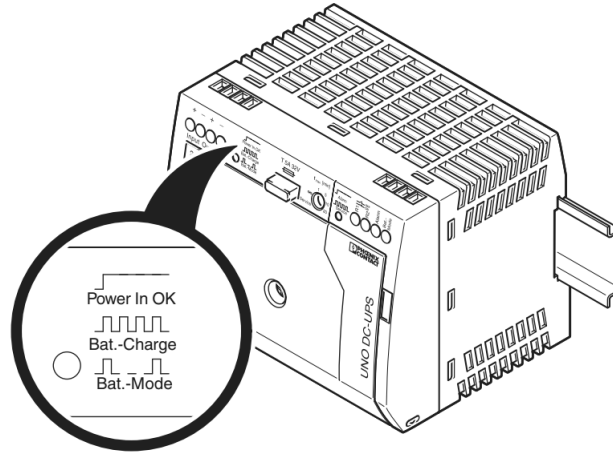

UPS LED Alarm Indicator - Red LED

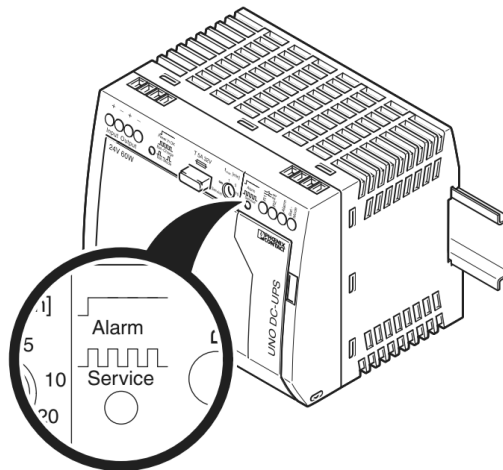

MOTORIZED CONTROL VALVE POWER BACKUP WIRING DIAGRAM

The valve is supplied with 6.5 feet of cable with 22 and 24 gauge wires. For greater distance between valve and controller use wire size as shown in Table 1: 24VAC/DC Power Wiring. Do not run Motorized Control Valve wiring with or near high voltage power wiring or VFD Controls (Variable Frequency Drives). Do not earth or ground 24 VAC wiring.

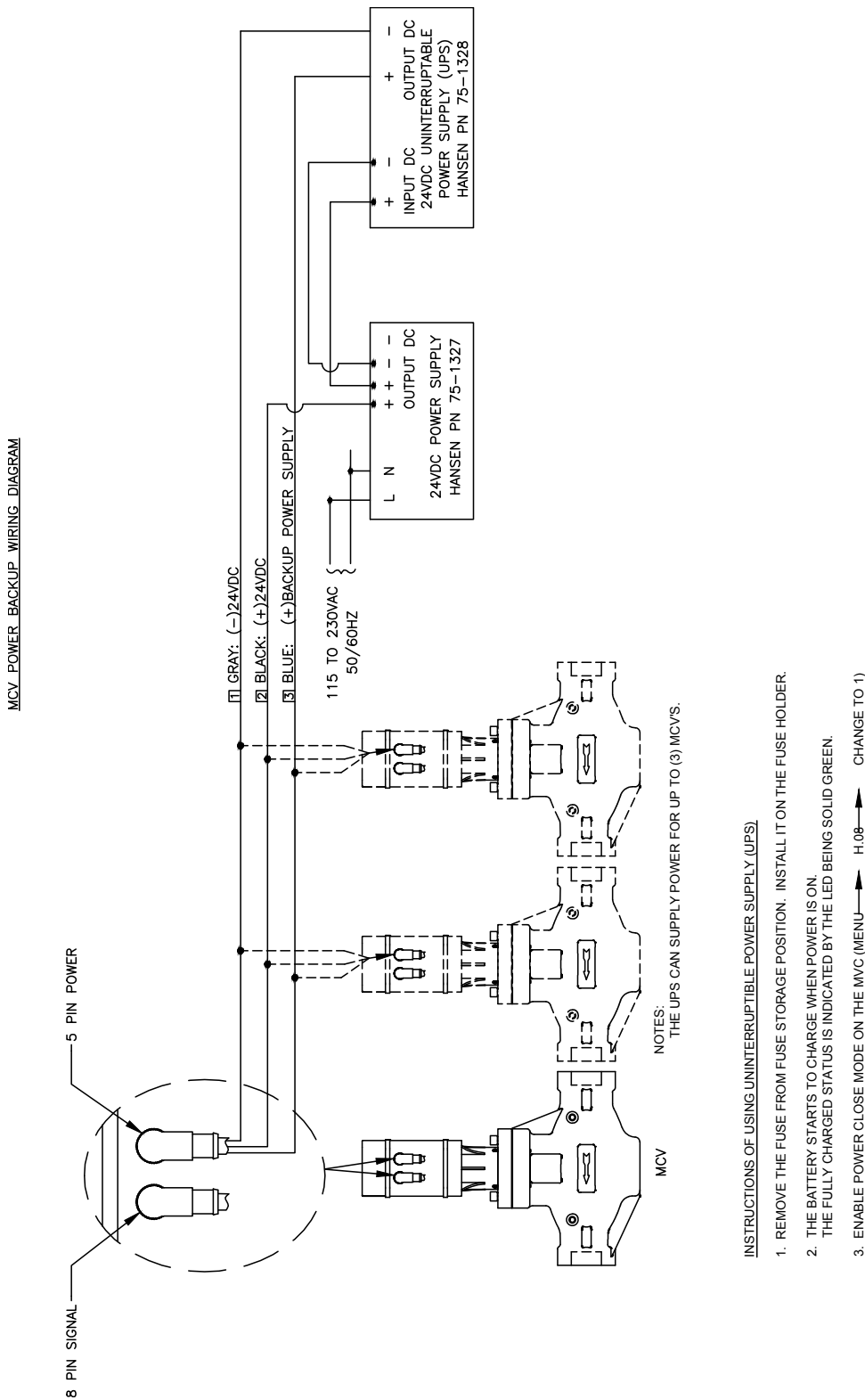

INSTALLATION DIMENSIONS, INCHES (MM)

3/4" THRU 1-1/4" MOTORIZED CONTROL VALVE INSTALLATION DRAWING

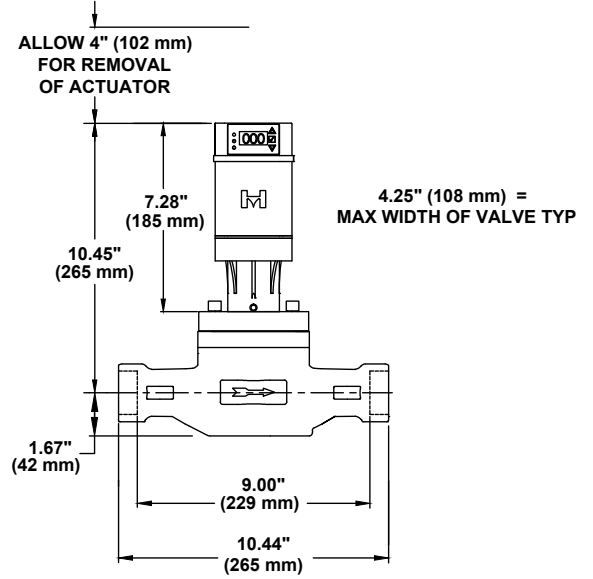
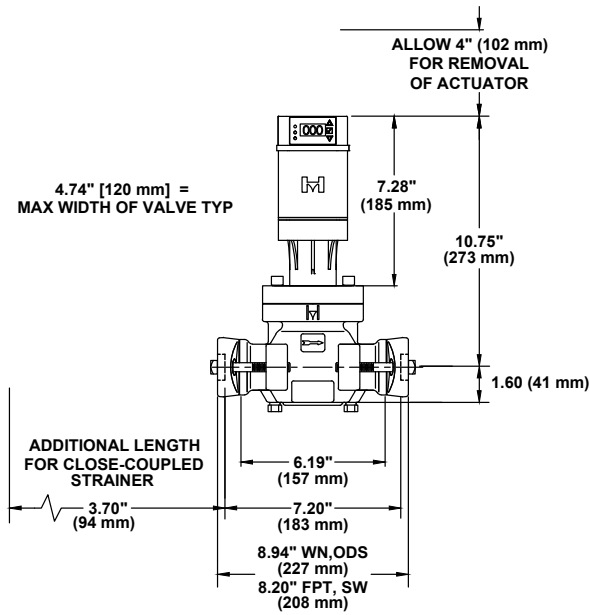

INSTALLATION DIMENSIONS, INCHES (MM)

1-1/2" THRU 2" MOTORIZED CONTROL VALVE INSTALLATION DRAWING

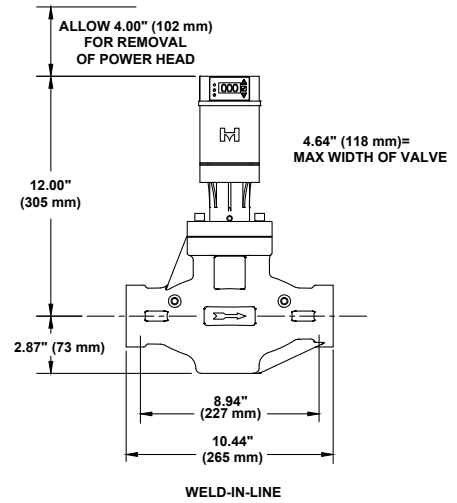
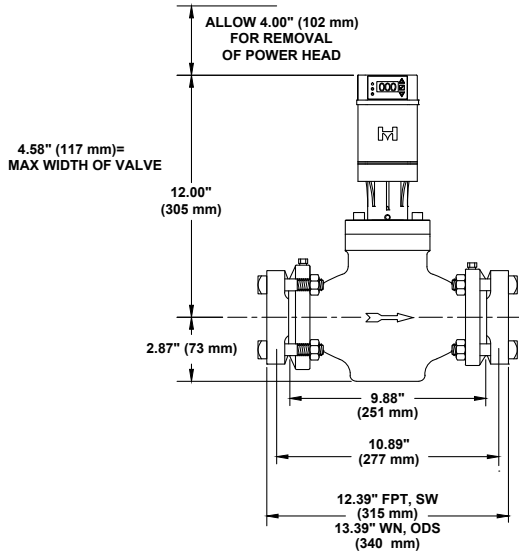

INSTALLATION OVERVIEW

Protect the interior of valve from dirt and moisture during storage and installation. Valve should be installed so that the arrow on the valve body is in direction of normal refrigerant flow.

Please note: Valve will not backflow if in closed position. *Do not install check valves upstream of the Motorized Control Valve without hydrostatic pressure relief.* Do not close the hand valve on inlet or outlet without making sure valve is in the open position. System should be free from dirt, weld slag and rust particles. A 60 mesh, close-coupled strainer is available for installation at inlet of valve for 3/4", 1" and 1-1/4". *Do not close-couple strainers to 1-1/2" through 2" Motorized Control Valves.*

1/4" NPT Gauge/Purge port connections are provided on the inlet and outlet of the 3/4" thru 2" valves standard.

Pipe sizing, valve placement, rating, anchoring, and similar prudent precautions should be taken to ensure "liquid hammer" will not occur when valves open or close.

For proper flange gasket sealing, care must be taken when threading or welding to assure flanges are parallel to each other and perpendicular to pipe. Also, gaskets should be lightly oiled and all bolts should be lubricated with an anti-seize and must be tightened evenly.

Protect cables during installation.

Do **not** mount the valve with the motor in the down position. The valve will **only** operate properly if the motor is mounted in a horizontal or upright position. Refer to diagrams below. Horizontal mounting of motor is satisfactory if oil and dirt are controlled.

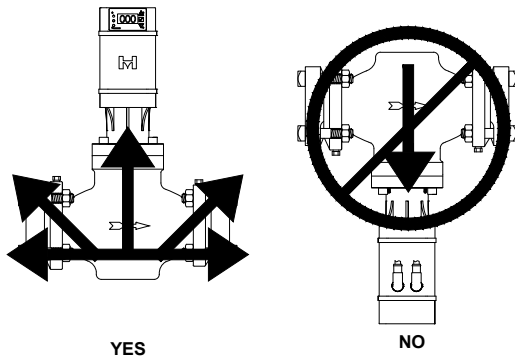

MANUAL CONTROL TOOL (MCT)

Use of the Manual Control Tool (MCT) requires the removal of the powerhead. Remove the cables to the powerhead to prevent the powerhead from spinning. Remove powerhead by loosening the set screws at the base. Do not remove the bonnet. Remove the powerhead and place the MCT over the cartridge. Manually operate the valve open or closed by turning the MCT. Rotate clockwise to open and counterclockwise to close. Refer to Table 2: Number of Turns to Actuate Valve for number of turns to fully actuate valve.

Before re-installing rotate the MCT counterclockwise until the Vport is closed. To re-install the powerhead, follow the installation instructions below.

TABLE 2: NUMBER OF TURNS TO ACTUATE VALVE

NOMINAL SIZE INCH	(MM)	NUMBER OF TURNS
3/4"-1-1/4"	(20-32)	7
1-1/2"-2"	(40-50)	12

INSTALLATION INSTRUCTIONS NEW COMPLETE VALVE

NOTE: Do not power on actuator until it is mounted to the valve and the set screws are properly torqued.

1. Remove valve, actuator, and remaining contents from box.
2. For flanged valves, align valve with arrow pointing in direction of flow and mount per install protocol. For weld in line valves, it is recommended to remove the cartridge/V-port assembly during welding by loosening bolts and removing bonnet. Replace cartridge/V-port assembly with new gasket after completion and torque bolts to 35 ft-lbs.
3. Install O-ring onto cartridge.
4. Place Manual Control Tool (MCT) onto the top of magnetic cartridge assembly. Continue to rotate the tool counterclockwise until the valve is closed and the V-port will no longer move.
5. Grease exterior of cartridge above the O-ring with supplied low temp, high load, low RPM grease such as Mobilith SHC PM 460 or similar.
6. Check the base of the actuator to ensure that the set screws are not protruding past the ID of the threaded ring. If necessary back the set screws out to prevent interference during installation.
7. Install new actuator onto cartridge. Press firmly down on the top of the powerhead to ensure it fully seats. The gap between the base of the actuator and bonnet should be less than 1/16".
8. Rotate actuator to orient in desired position and torque the 3 set screws at base to 4 in-lb using 3/32" hex key.
9. Wire the flying lead ends of the cable to power and the desired input signal and feedback loop per wiring diagram.
10. Connect the red and green cables to the actuator
11. Upon power-up, the valve will automatically calibrate.
12. Change input signal through the keypad display if not 4-20mA.

CONVERSION FROM SMV TO MCV

NOTE: Do not power on actuator until it is mounted to the valve and the set screws are torqued.

1. Isolate and pump down existing valve per PSMs.
2. Disconnect existing powerhead connections.
3. Remove existing can, powerhead from valve by loosening the screws.
4. Remove existing bonnet by loosening the bonnet bolts.
5. Remove existing can, cartridge and rotor cartridge. Ensure old gasket is removed from counter bore on top face of valve.
6. Remove new actuator and remaining contents from box.

7. Install new cartridge gasket to counter bore on top face of valve.
8. Ensure V-port is installed into new rotor cartridge. Install V-port into cartridge while fully supporting the V-port and cartridge and carefully aligning the threaded shaft of cartridge with the low friction nut of V-port. Carefully thread together 6-8 turns and align the anti-rotation slot on the V-port with the anti-rotation pin of the cartridge. Fully thread the V-port into the cartridge, screwing the V-port fully into the cartridge by turning the rotor clockwise.
9. Install new rotor cartridge/V-port assembly into valve.
10. Install new bonnet over cartridge assembly and torque bolts to 35 ft-lbs.
11. Install O-ring onto cartridge.
12. Place Manual Control Tool (MCT) onto the top of magnetic cartridge assembly. Continue to rotate the tool counterclockwise until the valve is closed and the V-port will no longer move.
13. Grease exterior of cartridge above the O-ring with supplied low temp, high load, low RPM grease such as Mobilith SHC PM 460 or similar.
14. Check the base of the actuator to ensure that the set screws are not protruding past the ID of the threaded ring. If necessary back the set screws out to prevent interference during installation.
15. Install new actuator onto cartridge. Press firmly down on the top of the actuator to ensure it fully seats. The gap between the base of the actuator and bonnet should be less than 1/16".
16. Rotate actuator to orient in desired position and torque the 3 set screws at base to 4 in-lb using 3/32" hex key.
17. For HMMR/HMMV replacement, connect the black 7 pin dangle connector to the existing connection already wired in place. The VPIF can be left in place if desired.

For HMSV replacement, cut off black 7 pin dangle connector wire connectors to power and input/output per wiring diagram.

NOTE: For HMSV replacement, it is important to remove the 24VAC to the pink and yellow relay signal wires. Voltage to this line will cause damage as the input should only be a closed contact switched to ground.

18. Connect the red and green cables to the actuator.
19. Upon power-up, the valve will automatically calibrate.
20. Program valve size and input signal through the keypad display.

USER INTERFACE MENU AND INSTRUCTION GUIDE

The user interface is located on the front of the valve and when in normal operation will display the % open of the valve Vport. The setup menu can be entered to automatically calibrate, adjust the control parameters, and view current settings. All displays in this menu start with the letter "H.". The keypad and display are shown below

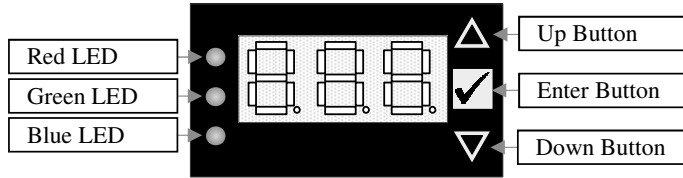

2. Upon entering, H.01 will be shown on the display.
3. Use the UP and DOWN arrow buttons to navigate through the list below.
4. To display and/or modify a value for that description, press the ENTER button.
5. Use the UP and DOWN arrow buttons to change the value.
6. Press the ENTER button to save the value. The display will return to the setup menu
7. Repeat steps 3-6 for all desired changes.
8. Exit the menu at any time by pressing and holding the ENTER button on the keypad for 3 seconds.

NOTE: Exiting the menu will NOT save the value to the valve .

NOTE: Valve can stay in Manual Mode (H.02) for an infinite amount of time.

If E.01 or E.02 become active, the valve will drive to zero and close until the signal issue has been rectified. Once the input signal is within the proper limits, the powerhead will return to normal operation.

To enter and navigate the menu, follow the steps below:

1. Press and hold the UP and DOWN arrow buttons on the keypad for 3 seconds

Setup Parameters

Display (Menu #)	Mode Description	Min Value	Max Value	Factory Setting	Comments
-	Normal Operation	0	100	-	Valve % Open
H.01	Re-Zero Calibration	0	1	0	0 = No Action 1 = Force motor to recalibrate zero Display will show CAL
H.02	Automated/Manual Mode	0	100	0	Mode becomes Manual when entered. Green LED will illuminate. Range: 0 - 100% when Enter is pressed
H.03	Valve Size	0	8	0	00 = 3/4" 02 = 1" 03 = 1-1/4" 04 = 1-1/2" 05 = 2" 07 = Future 08 = Future Valve will automatically calibrate after selection is made by pressing Enter
H.04	Input Signal Type	0	1	0	0 = 4-20mA 1 = 0-20mA 2 = 0-5Vdc 3 = 0-10Vdc 4 = 1-6Vdc 5 = Relay input
H.05	Output Signal Type	0	2	0	0 = 4-20mA 1 = 0-20mA
H.06	Operation Type	0	3	0	0 = Modulating (Direct) (input signal increase → % open increase) 1 = Modulating (Reverse) (input signal increase → % open decrease) 2 = Open/Close (Direct) (Closed relay → fully closed valve) 3 = Open/Close (Reverse) (Closed relay → fully open valve)
H.07	Speed	25	100	100	Motor speed adjustment Increments of 25%
H.08	Power Backup Supply Status	0	1	0	0 = Disabled 1 = Enabled
H.09	Power Backup Fail Safe Position upon power loss	0	3	0	Define motor position on power loss 0 = close 1 = open 2 = user defined position @ H. 10
H.10	Fail Safe Position when H.09 = 2	0	100	0	Number between 0 - 100 Increments of 10
H.11	Alarm Log	0	9	-	A0 = Active alarm A1 → A9 = logged alarm. A9 oldest
H. 12	Max. Open Limit	30	100	100	Max. Open must be greater than Min. Close increments of 10
H. 13	Min. Close Limit	0	40	0	Min. Close Limit must be less than Max. Open Limit in increments of 10
H. 14	Input Dampening	1	5	-	
H. 20	Password protected	0	999	-	
H. 21	Measuring Interval	1	50	-	
H. 34	Factory Reset			-	Input value of 1 will reset all parameters to factory defaults
H. 99	Software Version			-	Displays Software Version

Error Codes

Error #	Description	Notes
E.01	Input signal present on the 4-20mA Control Input greater than expected.	The 4-20mA signal present on the Control Input is greater than 22mA
E.02	Input signal present on the 4-20mA Control Input less than expected.	The 4-20mA signal present on the Control Input is less than 3mA
PF	Power Failure when the incoming voltage is less than expected.	The incoming voltage is less than 19V.

SERVICE AND MAINTENANCE

MCV MOTORIZED CONTROL VALVE

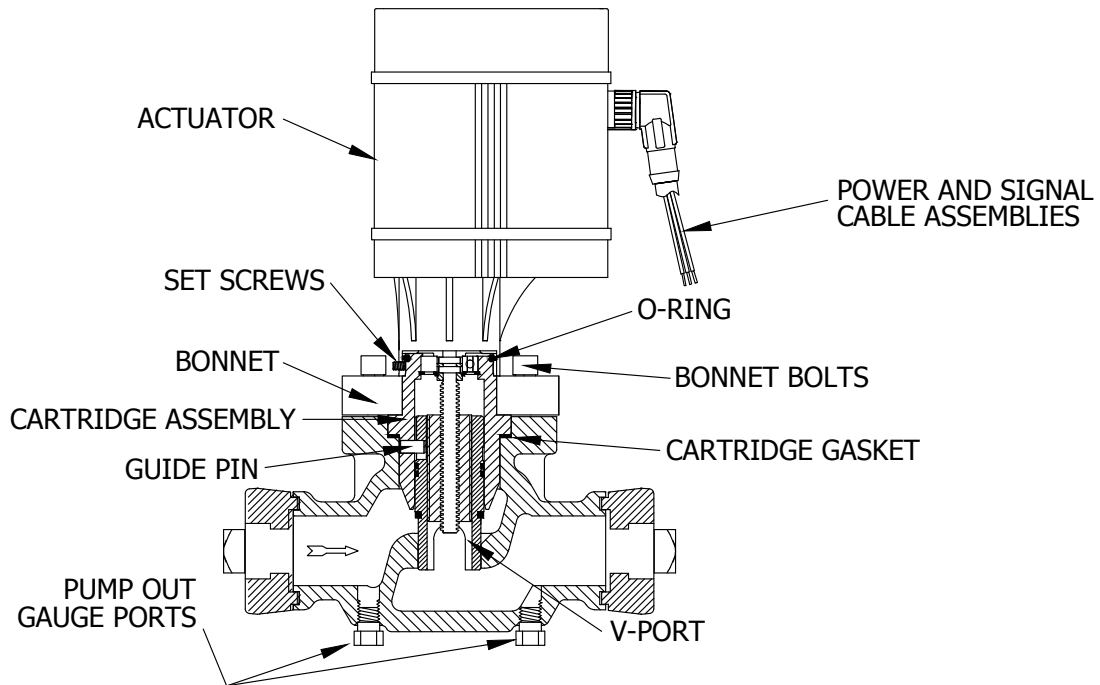

MCV DISASSEMBLY 3/4" THRU 2"

1. Isolate the valve from the refrigerant pressure and evacuate the refrigerant.

NOTE: Always use caution when removing the actuator and entering the valve cavity.

2. Disconnect the red and green cables from the actuator.
3. Remove the actuator by loosening but not removing the set screws.
4. To enter the valve cavity, carefully loosen and remove the larger bonnet bolts and then the bonnet.
5. Grasp the top of the cartridge and while lifting out squarely, remove the cartridge assembly, taking care not to bend the shaft. If cartridge removal is difficult, remove by placing the MCT on the cartridge and rotating counterclockwise and the cartridge will press out. WARNING: Don't bend shaft.
6. Remove the V-port from the cartridge assembly by unscrewing the rotor counterclockwise.

MCV REASSEMBLY 3/4" THRU 2"

1. Install new cartridge gasket to counter bore on top face of valve.
2. Ensure V-port is installed into new rotor cartridge. To install V-port into cartridge fully supporting the V-port and cartridge while carefully aligning the threaded shaft of cartridge with the low friction nut of V-port. Carefully thread together 6-8 turns, and align the anti-rotation slot on the V-port with the anti-rotation pin of the cartridge. Fully thread the

V-port into the cartridge, screwing the V-port fully into the cartridge by turning the rotor clockwise.

3. Install new rotor cartridge/V-port assembly into valve.
4. Install new bonnet over cartridge assembly and torque bolts to 35 ft-lbs.
5. Install O-ring onto cartridge.
6. Place Manual Control Tool (MCT) onto the top of magnetic cartridge assembly. Continue to rotate the tool counterclockwise until the valve is closed and the V-port will no longer move.
7. Grease exterior of cartridge above the O-ring with supplied low temp, high load, low RPM grease such as Mobilith SHC PM 460 or similar.
8. Check the base of the actuator to ensure that the set screws are not protruding past the ID of the threaded ring. If necessary back the set screws out to prevent interference during installation.
9. Install new actuator onto cartridge. Press firmly down on the top of the actuator to ensure it fully seats. The gap between the base of the powerhead and bonnet should be less than 1/16".
10. Rotate actuator to orient in desire position and torque the 3 set screws at base to 4 in-lb using 3/32" hex key.
11. Connect the red and green cables to the actuator.

12. Upon power-up, the valve will automatically calibrate.

MOTORIZED CONTROL VALVE PARTS LIST

3/4"(20mm) - 2"(50mm) MCV & MCR MOTORIZED CONTROL VALVE

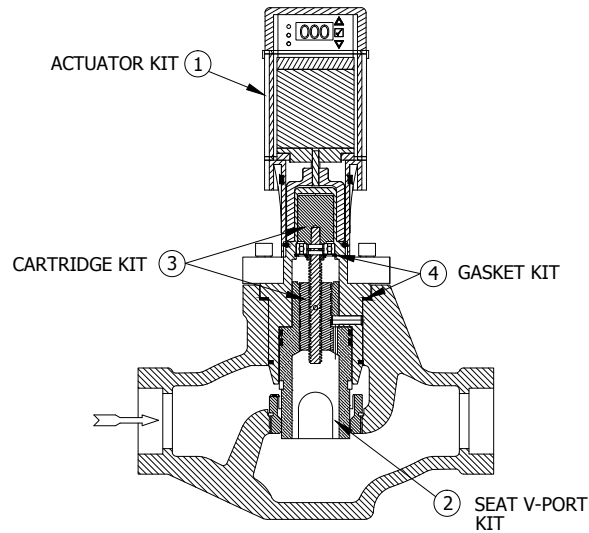

Valve Type	Nominal Size Inch mm	1		2		3	4	Conversion Kits			
		Actuator Kit		Seat/Vport Assembly kit				Cartridge Assembly Kit	Gasket Kit	SMV to MCV Conversion Kit (excludes Vport)	SMV Power Close to MCV Power Backup Conversion Kit (excludes Vport)
		Standard	Power Backup	P/N	Cv						
MCV	3/4" (20)	75-1320 (Actuator only)	75-1320 +HUPS (Actuator with UPS, DC Power Supply)	75-1154	6.4	75-1325 (Cartridge, gasket, oring, grease, hex key)	75-1322	75-1318 (Actuator, Dongle Cable, Cartridge, Bonnet, Bolts, Gasket, Oring, Grease)	75-1318 + HUPS (Actuator, Dongle Cable, Cartridge, Bonnet, Bolts, Gasket, Oring, Grease)		
	1" (25)			75-1155	11.7						
	1-1/4" (30)			75-1156	16.4						
	1-1/2" (40)			75-1157	35						
	2" (50)			75-1166	47						
MCR	3/4" (20)			75-1320 (Actuator only)	75-1320 +HUPS (Actuator with UPS, DC Power Supply)	75-1160	2.2	75-1325 (Cartridge, gasket, oring, grease, hex key)	75-1322	75-1318 (Actuator, Dongle Cable, Cartridge, Bonnet, Bolts, Gasket, Oring, Grease)	75-1318 + HUPS (Actuator, Dongle Cable, Cartridge, Bonnet, Bolts, Gasket, Oring, Grease)
	1" (25)					75-1161	3.9				
	1-1/4" (30)					75-1154	5.5				
	1-1/2" (40)					75-1162	12				
	2" (50)					75-1163	16				
MCRB	1-1/2" (40)	75-1320 (Actuator only)	75-1320 +HUPS (Actuator with UPS, DC Power Supply)			75-1230	6	75-1326 (Cartridge, gasket, oring, grease, hex key)	75-1323	75-1319 (Actuator, Dongle Cable, Cartridge, Bonnet, Bolts, Gasket, Oring, Grease)	75-1319 + HUPS (Actuator, Dongle Cable, Cartridge, Bonnet, Bolts, Gasket, Oring, Grease)

* CARTRIDGE ASSEMBLY KIT, CAN KIT AND SEAT/V-PORT KIT INCLUDE GASKET KIT (Column 5)

** ACTUATOR KITS INCLUDE REPLACEMENT GASKET AND SCREWS

MOTORIZED CONTROL VALVE RECOMMENDED PIPING

FIGURE 1: LIQUID FEED VALVE FROM INTERMEDIATE TO LOW TEMPERATURE VESSEL

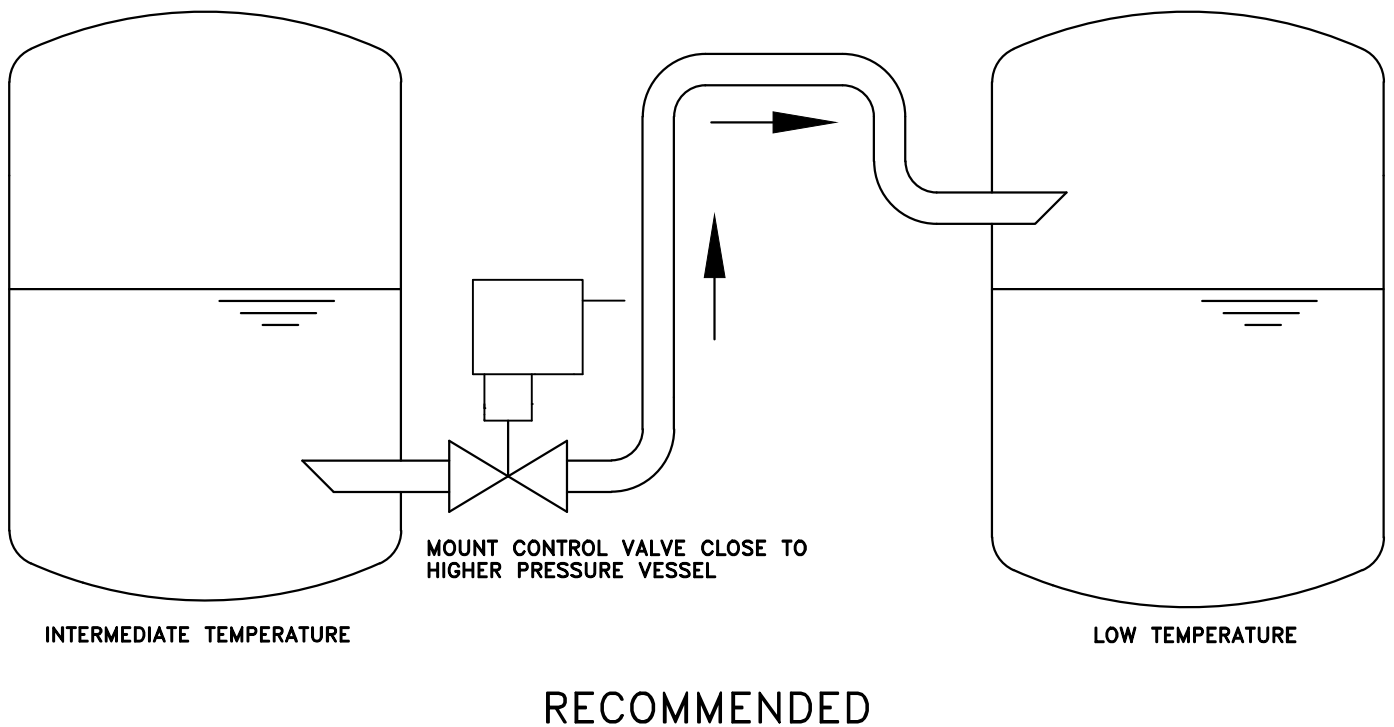
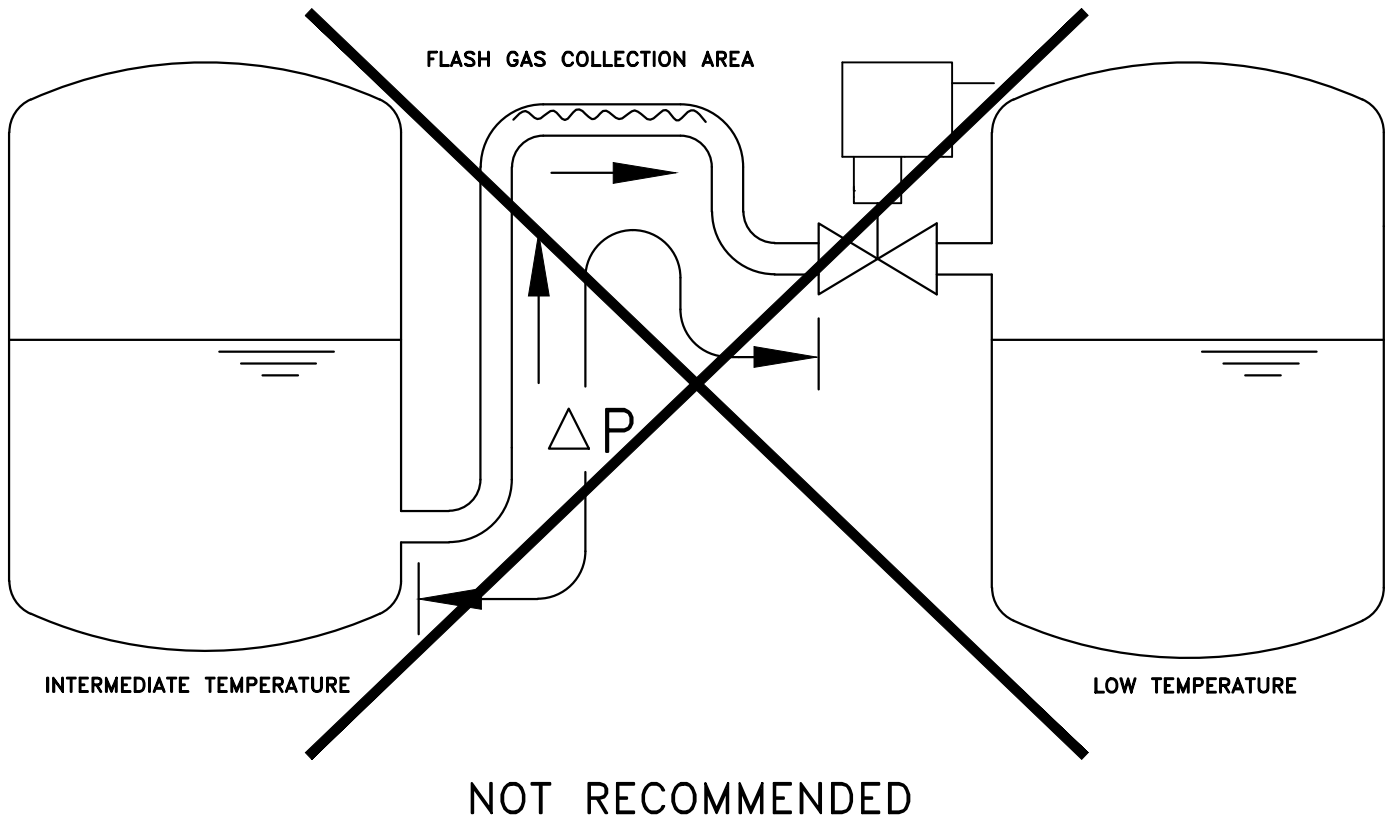

MOTORIZED CONTROL VALVE RECOMMENDED PIPING

FIGURE 2: PIPING RECOMMENDATIONS

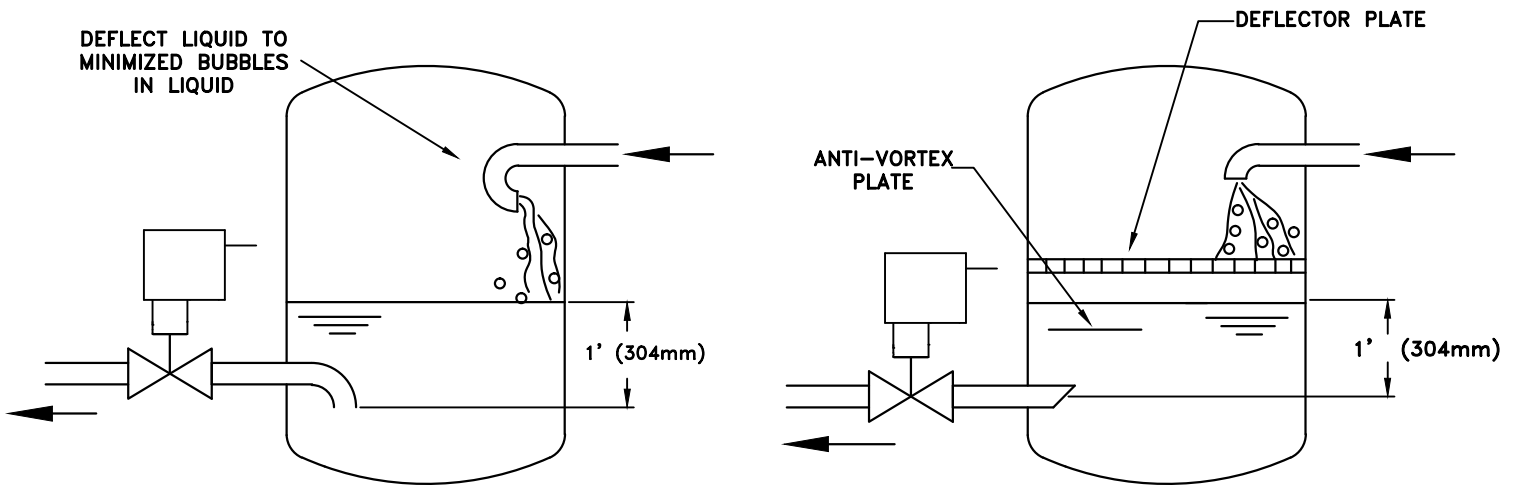
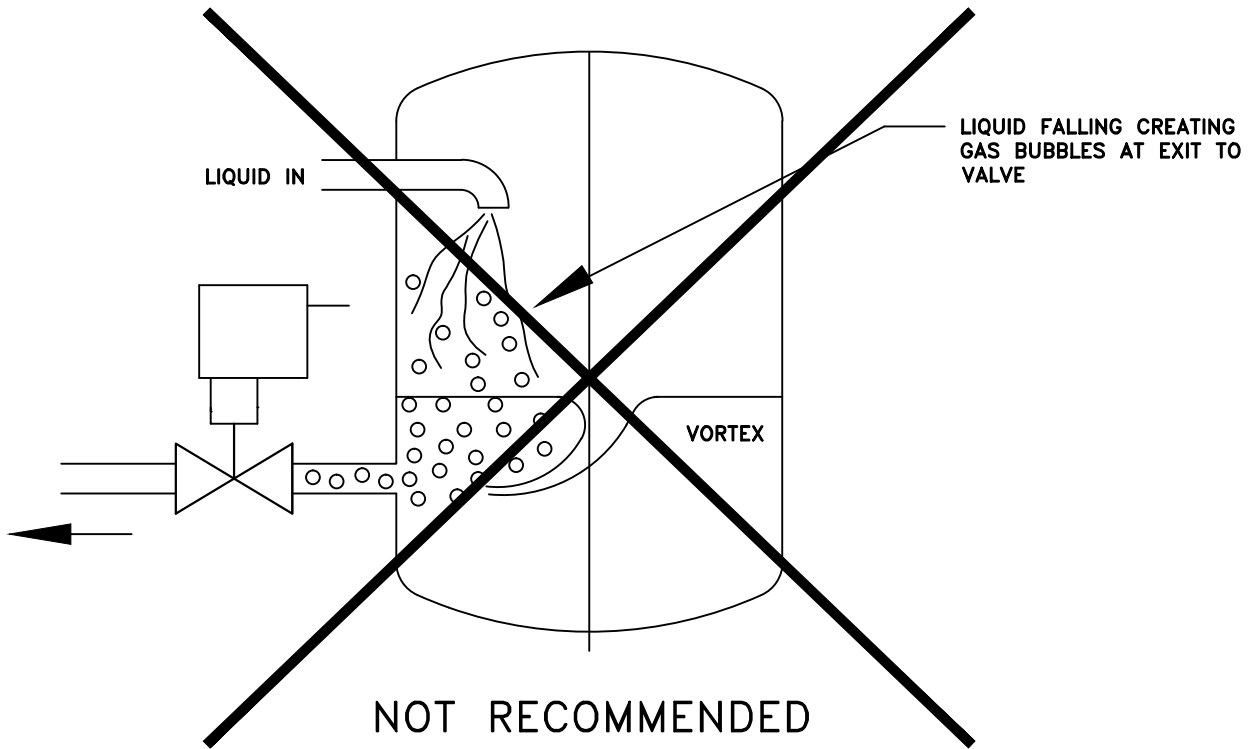

RECOMMENDED

HANSEN CONTROLLERS

HANSEN PXVC CONTROLLERS

The PXVC Intelligent, single loop, PID controller is a standalone cabinet mounted electronic universal controller. The Hansen PXVC controller can be configured for several different applications. The controller, with factory defaults, will give reasonably good control. If control difficulties occur during startup, it is recommended first to thoroughly check system and components for proper installation,

operation, and sensor location before attempting to tune the PXVC controller. Field alteration of the controller configuration is not recommended. Controller tuning of the P-I-D is performed in the "parameters" section and are the only parameters the user may need to optimize.

See the PXVC Universal Controller Bulletin found at www.hantech.com for more information.

TECHNICAL SPECIFICATIONS

		PXVC-PT	PXVC-P, PXVC-T, PXVC-L
POWER SUPPLY	Operating Voltage	24V AC, 50/60 Hz \pm 10% (OR) 24VDC	
	Power Consumption	Max. 3 VA	
	Electrical Connection	Terminal Connectors, Removable AWG 24...12	
SIGNAL INPUTS	Input #1	Pressure Transducer	Model Dependent, See Wiring Diagram
	Input #2	Temperature Sensor	Dry Contact Closure
	Input #3	Dry Contact Closure	Not Available
SIGNAL OUTPUTS	Output #1	N/A	
	Output #2	Alarm, 24...250VAC, 1A max, TRIAC	
	Output #3	4-20 mA @ 24VDC	
ENVIRONMENT	Temperature	32...122°F (0...50°C)	
	Humidity	< 95% r.H. non-condensing	
STANDARDS	conform according to EMC Standard 89/336/EEC EMEI Standard 73/23/EEC	EN 61 000-6-1/EN 61 000-6-3	
	Degree of Protection	NEMA1, IP30	
	Safety Class	I1 (IEC 60536)	
	Cover, back part	Fire proof ABS plastic (UL94 class V-O)	
	Weight (including package)	8.5 oz (240 g)	

*Optional IP65 Enclosure available, See page 38

DIMENSIONS

(IN, MM)

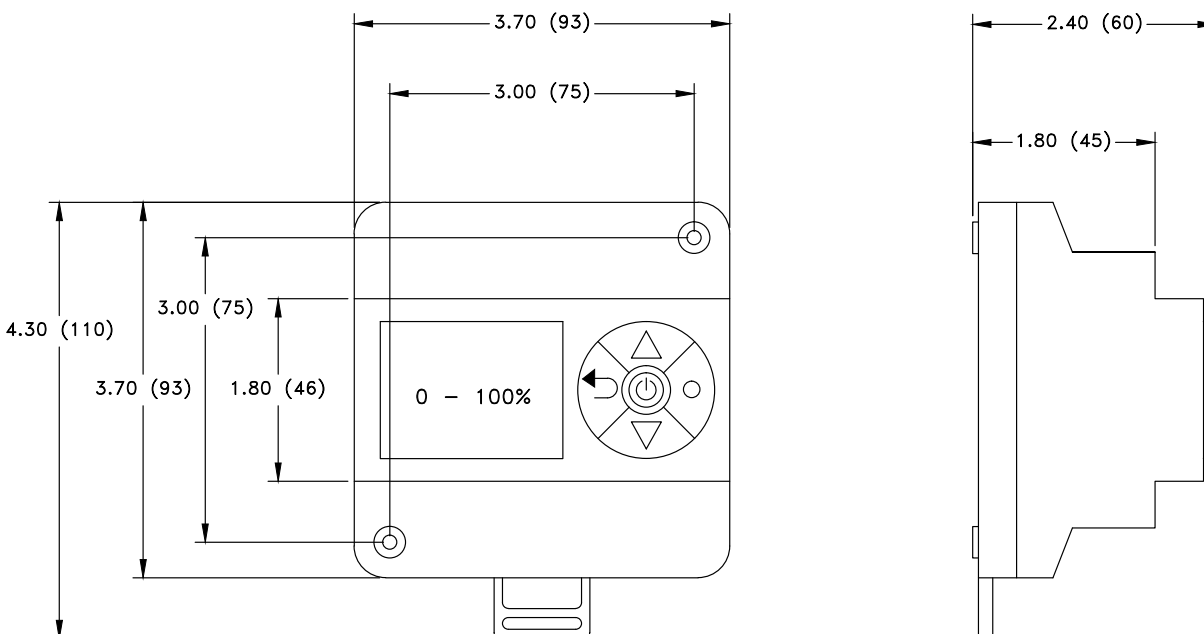

**PXVC-PT (PRESSURE TEMPERATURE)
SUPERHEAT/SUBCOOLING CONTROL
OVERVIEW**

The PXVC-PT controller is used in applications where the system temperatures are not less than -20°F (-28.9°C). It is factory programmed to provide precise control of the

Hansen Motorized Control Valve for direct expansion evaporators. The two inputs, pressure transducer and temperature probe, are used to determine the amount of Superheat or Subcooling in a controlled refrigeration system. The PXVC-PT controls the Motorized Control Valve to modulate the refrigerant flow necessary to maintain a set for superheated gas leaving the evaporator.

DISPLAY AND KEYBOARD OPERATION

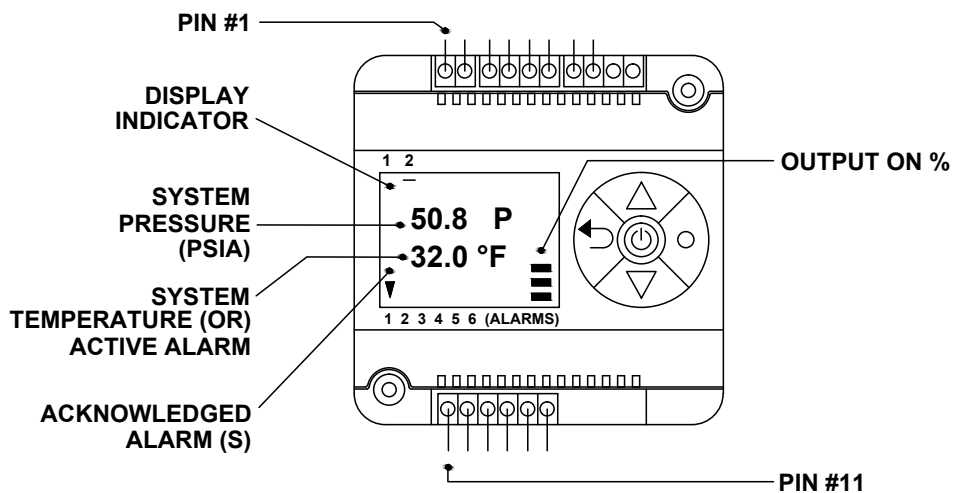
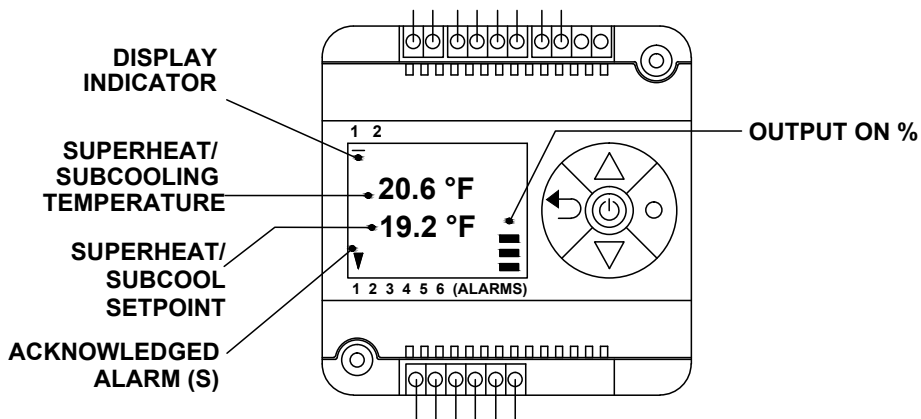

PXVC-PT FUNCTION KEYS

- Center (POWER) Key: > 2 seconds to TURN OFF the controller; Remote Interlock must be disabled. Parameter Setting: ENTER to select menu option and ACCEPT parameter change.
- UP Key: Increase SETPOINT. Parameter Setting: SCROLL menu options and paramters.
- Right (OPTIONS) Key: Acknowledge alarm conditions. Alarm message disabled for 15 seconds, priority 1-6. Parameter Settings: Enter to select menu options, and ACCEPT parameter change.
- Left (ESC) Key: Toggle between screens 1 and 2. Parameter Setting: Escape, menu option, discard parameter setting.

TYPICAL WIRING DIAGRAM for PXVC-PT

PXVC-PT SUPERHEAT/SUBCOOLING CONTROL VIA MCV (AMMONIA ONLY)
TYPICAL WIRING DIAGRAM 115/230VAC

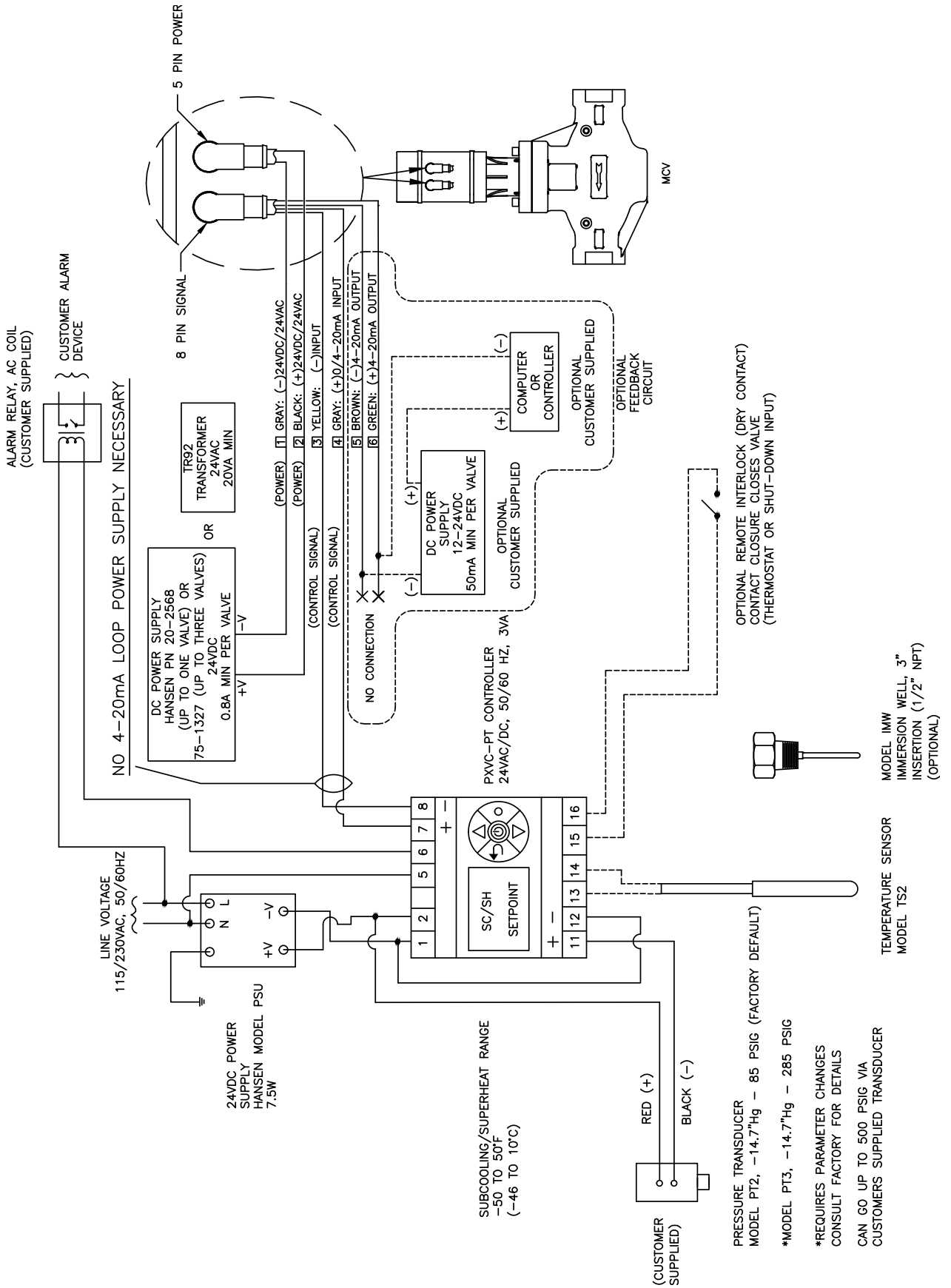

PXVC-T, PXVC-L, PXVC-P CONTROLLERS

PXVC-T (TEMPERATURE) CONTROL

The Hansen PXVC-T Controller is factory programmed to provide precise control of temperature in applications such as Liquid Injection of screw compressors. A temperature sensor, included, provides an input to the Hansen PXVC-T controller which controls the Hansen Motorized Control Valve. The valve modulates the refrigerant flow necessary to maintain a set for discharge gas temperature.

PXVC-L (LEVEL) CONTROL OF FLOODED EVAPORATORS

The Hansen PXVC-L Controller is factory programmed to provide precise control of liquid level in flooded evaporators, small liquid recirculators, and other refrigerant level vessels. A 4-20 mA input signal from the Hansen VLT level probe, Hansen Vari-Level with 4-20 mA, or other liquid level device to the Hansen PXVC-L controller which controls the Hansen Motorized Control Valve. The valve modulates the refrigerant flow necessary to maintain a set-for liquid level in the vessel.

PXVC-P (PRESSURE) CONTROL

The Hansen PXVC-P Controller is factory programmed to provide precise control of pressure in applications such as hot gas bypass to suction of a compressor. A pressure sensor, available from Hansen, provides an input to the Hansen PXVC-P controller which controls the Hansen Motorized Control Valve. The valve modulates the refrigerant flow necessary to maintain a set for pressure.

SELECTION OF SENSORS

Temperature Probe (Included)

- TS1, temperature sensor, NTC10K, length 2 inches with 6.5 feet cable (Refer to Table 1 on page 3 for extended cable lengths)
- IMW, temperature probe immersion well, length 4"

Pressure Transducer (Available)

- PT2, pressure transducer, -14.7–85 psig, 24VDC, 4-20mA output
- PT3 pressure transducer, -14.7–285 psig, 24VDC, 4-20mA output (Factory Default)

Subheat/Subcooling

- Hansen HPT

Level Control

- Hansen VLT probe or similar

SELECTION OF CONTROL VALVES

Motorized Valves

- Hansen MCR, MCR

POWER FAILURE

Upon power-interruption, all parameters and set-points are memorized in non-volatile memory, and therefore do not have to be re-entered.

ERROR MESSAGES

Err1: Temperature sensor faulty or missing.

Err3: Parameter error; check the input parameter settings.

Err4: Failure of an internal component required for operation. Product must be replaced.

ELECTRICAL CONNECTIONS

In an extremely impaired EMC environment use only shielded cables for input/output connections.

Use safety insulating transformers with double insulation; they must be designed for 100% ON-time.

DC voltage coils are not recommended for Pulse-Width Modulation applications.

RAMP UP DELAY

Ramp up delay provides a soft start control at startup. The active state is shown by the clock symbol on the display. At power-up or going from closed to open contacts on the INTERLOCK input, the controller will operate in "RAMP UP DELAY" mode for 2 minutes (default) or a predefined time (IL27 not equal to zero). During the countdown, the P-band is doubled and the KI-bands are halved resulting in a **slower** control response.

DISPLAY AND KEYPAD OPERATION

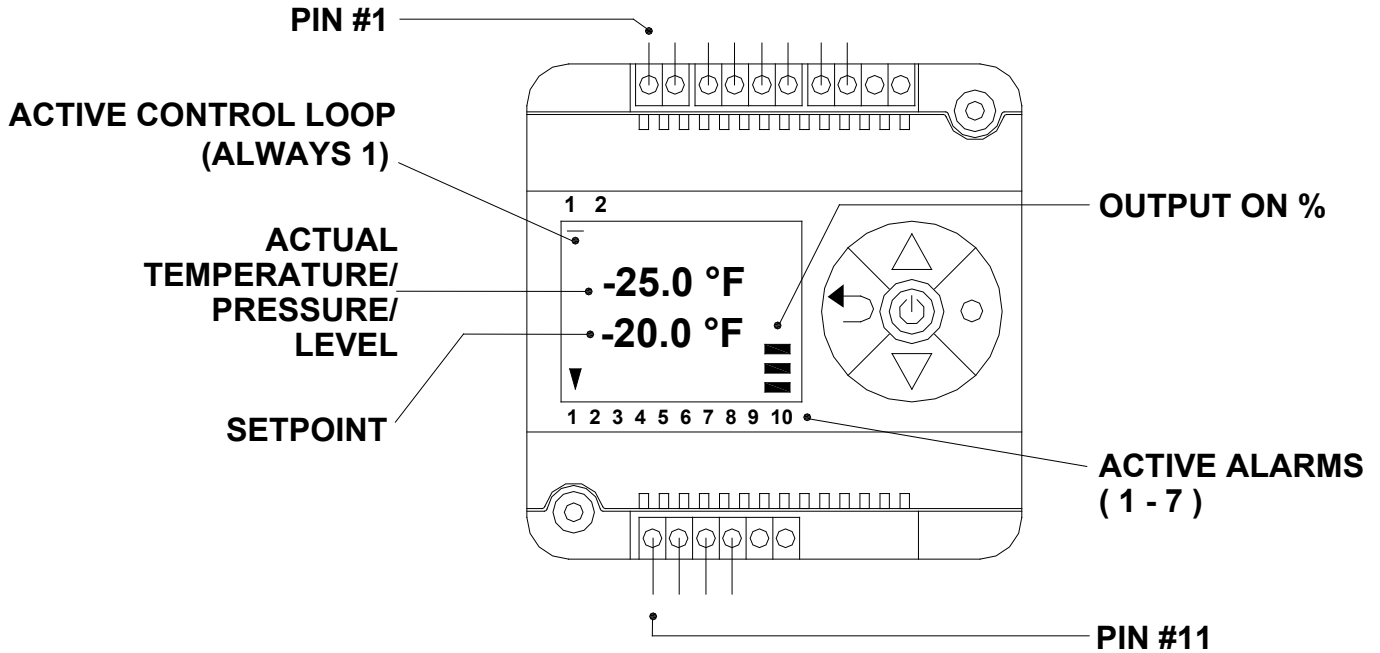

PXVC FUNCTION KEYS

- Center button (POWER): Pressing the button for more than 2 seconds switches the unit off – with Remote Interlock disabled.
- Up button: Increment set points and parameters, select menu options.
- Down button: Decrement set points and parameters, select menu options.
- Right button: Access for different control modes. Advance setting.
- Left button: Access for different control modes. Acts as escape to leave menu levels or discard parameters.

PXVC TERMINAL DESCRIPTIONS

Terminal 1	Power Supply	24V AC/DC (-)
Terminal 2	Power Supply	24V AC/DC (+)
Terminal 11, 12	Input 1:	<ul style="list-style-type: none"> - P: Hansen PT3 (-14.7 to 285 psig/20.6 bar) <i>Factory Default</i> OR <ul style="list-style-type: none"> ▲ Hansen PT2 (-14.7 to 85 psig/6.8 bar) Loop Power Supply needed (+24VDC) - T: Temperature, Hansen TS1 Sensor (Included) Hansen IMW, 4" Immersion Well (Purchase Separately) - CI: System Controller (Custom Supplied) - DX: Hansen HPT Pressure/Temperature Transducer; Specify Refrigerant (R717, R22, R134a, R404A, R507A, Propane, CO₂) (+24VDC Loop Power Supply needed) - L: Hansen VLT or Similar (+24VDC Loop Power Supply needed)
Terminal 13, 14	Input 2:	Optional Remote Interlock, Dry Contact
Terminal 5, 6	*Output 2, Triac:	Alarm(s)
Terminal 7, 8	Output 3, 4-20mA:	Alternate 4-20mA Output for Hansen MCV (No Loop Power Supply needed)

* WITH INTERNAL SNUBBERS

▲ REQUIRES PARAMETER CHANGES. REFER TO FACTORY.

TYPICAL WIRING DIAGRAM FOR PXVC-T (TEMPERATURE)

PXVC-T TEMPERATURE CONTROL VIA MCV
 TYPICAL WIRING DIAGRAM 115/230VAC

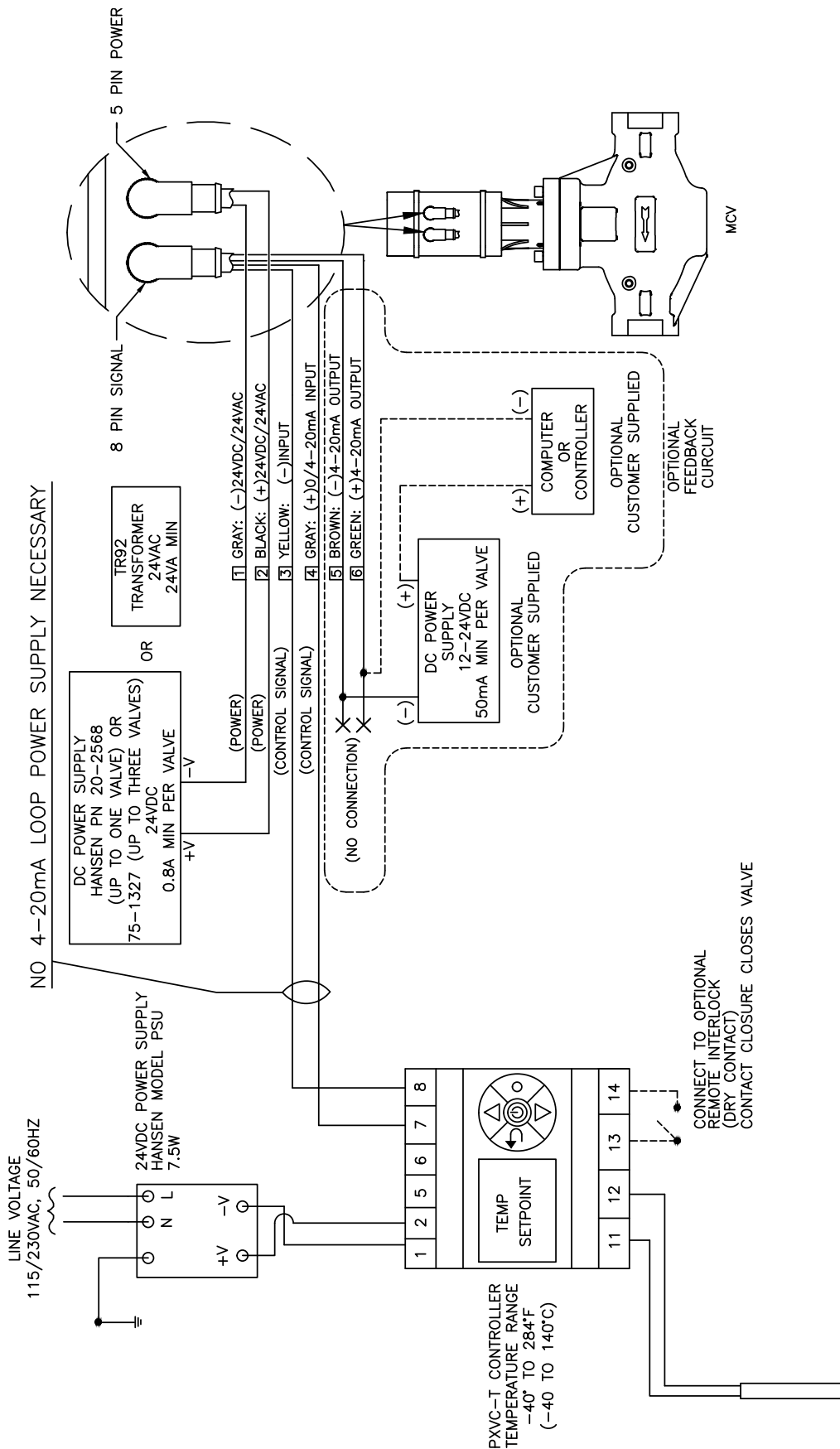

INSTALLATION PARAMETERS FOR THE MOTORIZED CONTROL VALVE

VALVE DESCRIPTION

Catalog Number: _____
(from nameplate on valve bonnet)

Port Size: _____

Serial Number: _____

Valve Tag: _____

INSTALLATION DESCRIPTION

Location Description: _____
(e.g. Evaporator #6, suction valve, outdoors)

Installation Location (facility name, city, state): _____

APPLICATION DESCRIPTION

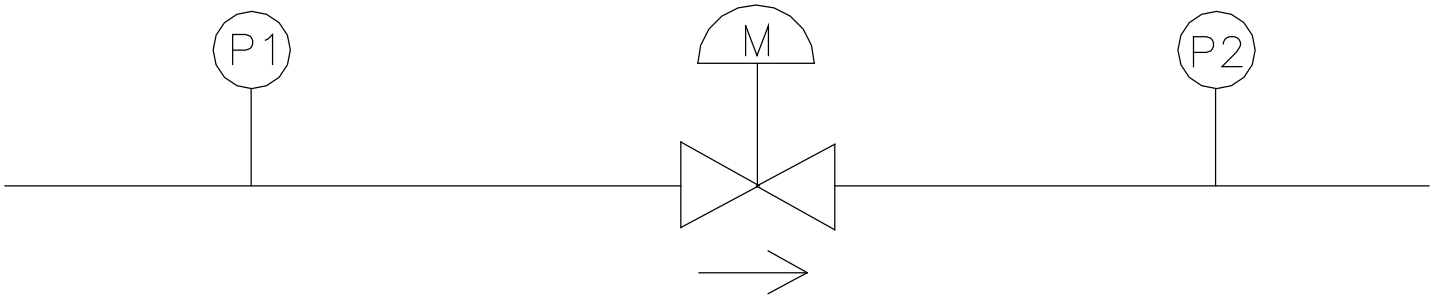

Inlet Pipe Size: _____

Outlet Pipe Size: _____

Inlet Temperature: _____

Outlet Temperature: _____

Inlet Pressure (P1): _____

Outlet Pressure (P2): _____

Pressure Drop (P1-P2): _____

Refrigerant: _____

Service Type (Dry or Wet Suction, liquid make-up, hot gas, liquid feed, etc.): _____

Rated Capacity of Valve (per capacity tables based on Pressure Drop above): _____

Application High Load Capacity: _____ Percent of Rated Capacity of Valve _____ %

Application Low Load Capacity: _____ Percent of Rated Capacity of Valve _____ %

Typical valve position (based on Display or PLC trending): _____ %

CAUTION

Hansen valves are for refrigeration and other Hansen approved systems only. These instructions and related safety precautions must be read completely and understood before selecting, using, or servicing these valves. Only knowledgeable, trained refrigeration technicians should install, operate, or service these valves. Stated temperature and pressure limits should not be exceeded. Bonnets should not be removed from these valves unless the system has been evacuated to zero pressure. See also Safety Precautions in current List Price Bulletin and Safety Precautions Sheet supplied with product. Escaping refrigerant can cause injury, especially to the eyes and lungs.

WARRANTY

Hansen electrical and electronic parts are guaranteed against defective materials and workmanship for 90 days F.O.B. our plant. All other components are guaranteed for one year F.O.B. our plant. No consequential damages or field labor is included.

TYPICAL SPECIFICATIONS

Motor operated control valves shall feature direct actuation of the main valve seat by the motor shaft, a canned motor to eliminate valve stem seal leakage, a ductile iron body, and be suitable for a safe working pressure of 400 psig (28 bar), as manufactured by Hansen Technologies Corporation, or approved equal.

ORDERING INFORMATION

FPT only available up to and 1¼" port size.

NOMINAL PORT SIZE		FLANGE CONNECTION STYLES AND SIZES		
		FPT, SW, WN		ODS
INCH	(MM)	STANDARD	ALSO	STANDARD
3/4"	(20)	3/4"	1, 1-1/4"	7/8"
1"	(25)	1"	3/4", 1-1/4"	1-1/8"
1-1/4"	(32)	1-1/4"	3/4", 1"	1-3/8"
1-1/2"	(40)	1-1/2"	2"	1-5/8"
2"	(50)	2"	1-1/2"	2-1/8"

TO ORDER:

Specify valve type (MCV, MCR), nominal port size, flange connection style and size.

motorized control valves with weld-in connections available (3/4" thru 2"), contact factory.

OPTIONAL CONTROLLERS

MCV/MCR OPTIONAL CONTROLLERS	
CAT NO	DESCRIPTION
PXVC-T	Temperature controller with temperature sensor for fully modulating temperature control.
PXVC-L	Level controller for fully modulating applications. Level sensor not included.
PXVC-P	Pressure controller with pressure transducer for fully modulating pressure control.
PXVC-PT	Direct expansion or super heat controller for fully modulating applications.
RDR	Remote digital readout displays valve position
WTE	Watertight Enclosure (NEMA4 for above controller)
PSU2	Compact Power Supply (100-240VAC: 24VDC) for above controller

OPTIONAL EQUIPMENT	
MCT	Manual Control Tool
HUPS	Uninterruptable Power Supply and DC power supply for up to 3 valves
75-1321	Cable set 2m long
75-1329	Cable set 5m long



Hansen Technologies Corporation
681 Commerce Street

Burr Ridge, Illinois 60527 USA

Tel: 630.325.1565 Fax: 630.325.1572 Toll: 866.4HANSEN

Email: sales@hantech.com Web: www.hantech.com

USA • Asia • Europe • India • Latin America • Middle East

© Hansen Technologies Corporation