



EZ-SRV™

Cartridge Pressure-Relief Valve with EZ-Fitting

INTRODUCTION

Hansen EZ-SRV™ cartridge pressure-relief valves protect refrigeration pressure vessels and other refrigeration system components from excessive pressure. If an abnormally high pressure occurs, the cartridge pressure-relief valve will open to relieve the excess pressure, preventing potential damage to equipment and injury to personnel.

Hansen EZ-SRV™ relief valves are built in strict conformance with both ASME Boiler and Pressure Vessel Code requirements and ISO 4126 – Safety Devices for Protection of Excessive Pressure. Each valve bears the ASME code symbol of certification (UV). The CE mark as required for EU member countries is pending. Valve capacities are rated by the National Board of Boiler and Pressure Vessel Inspectors (NB).

Refrigeration pressure-relief valves are recommended for replacement at least every five years. However, if a relief valve has discharged, it must be replaced as soon as possible. Valve replacement with the Hansen EZ-SRV™ is fast and easy – saving significant time and expense compared to traditional relief valves.

The cartridge valve can be replaced more safely than previously available pressure-relief valves. The Hansen EZ-Fitting has a 1/4" NPT connection on the side of the body. A 1/4" gauge valve installed with a tell-tale pressure gauge can indicate overpressure of a valve and if pressure is present when servicing, the 1/4" gauge valve can also be used to safely bleed-off residual pressure between the three-way manifold valve and the EZ-SRV™ valve.

The EZA Cartridge Relief Valves have the lowest rated capacity available. This low capacity rating means that required discharge line and header sizes are minimized thereby reducing installation costs. Furthermore, using these valves may enable existing relief systems to comply with current standards.

Specifications, Applications, Service Instructions & Parts

EZ-SRV™ CARTRIDGE PRESSURE-RELIEF VALVES

For Ammonia and Halocarbon Refrigeration Systems

KEY FEATURES

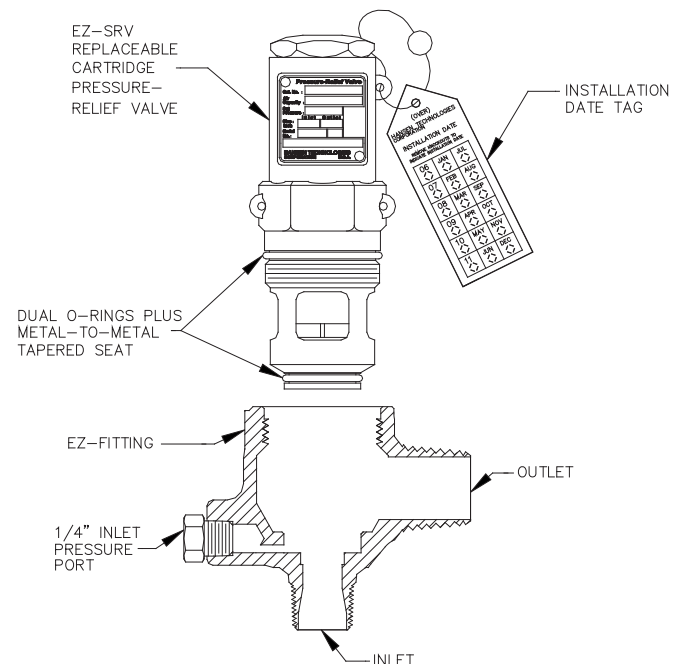

ADDITIONAL FEATURES

- Cartridge design allows quick and easy replacement.
- Matched capacities to existing Hansen H5600 "R" series
- Lowest capacity (EZA) ideal for oil pots, surge drums, and transfer drums
- Low blowdown (15% or less) for gas service
- EZ-Fitting is a permanent fixture, available with welded or threaded end connections
- MPT inlet eliminates need for nipple
- EZ-Adapter component available for retrofit of existing Hansen relief valves
- Liquid Rated Relief Valve (EZLQ) available

APPLICATIONS

Hansen EZ-SRV™ cartridge pressure-relief valves typically are installed on pressure vessels to protect from overpressure. Several design codes for refrigeration systems require that pressure vessels have protection from excessive pressure. For example, Hansen cartridge pressure-relief valves comply with the requirements of ANSI/ASHRAE Standard 15 Safety Standard for Refrigeration Systems, and ANSI/IIAR 2 Equipment, Design, and Installation of Closed-Circuit Ammonia Mechanical Refrigerating Systems. Once installed, a properly selected Hansen EZ-SRV™ cartridge pressure-relief valve will vent to atmosphere excessive overpressure. After discharge, these valves will quickly reseal to minimize loss of refrigerant. After discharge, relief valves must be replaced as soon as possible because debris may have settled on the seat, allowing the seat to leak out refrigerant. Hansen EZ-SRV™ valves must be installed in the vapor space above the liquid level of any vessel or component which contains liquid and vapor. (Hansen offers the EZLQ, a liquid relief valve for use with ASME rated pressure vessels and is rated U.S. GPM.)

MATERIAL SPECIFICATIONS

EZ-Fitting Body: ASME SA105 steel

EZ-SRV™ Cartridge: ASME SA395, ductile iron

Internal Seating Components: stainless steel

Piston: stainless steel

Seat O-rings: neoprene

Spring: stainless steel

Maximum Temperature Rating: 240°F (115°C)

Safe Working Pressure: 600 psig (40 bar)

Setting Range:

Gas Service: 150 to 600 psig (10.4 to 40 bar)

Liquid Service: 50 to 100 psid (3.4 to 6.9 bar)

Reseat Pressure (blowdown):

Gas Service: within 15% below set point

Liquid Service: within 20% below set point

CODE AND STANDARD COMPLIANCE

ASME Boiler and Pressure Vessel Code, Section VIII, Division 1

ANSI/ASHRAE Standard 15 Safety Standard for Refrigeration Systems

ANSI/IIAR 2 Equipment, Design, and Installation of Closed-Circuit Ammonia Mechanical Refrigerating Systems

ISO 4126, Safety Devices for Protection of Excessive Pressure

PED (Pressure Equipment Directive) Category IV (pending)

NAMEPLATE INFORMATION

The nameplate, located on the side of Hansen EZ-SRV™ cartridge pressure-relief valves, contains important information about the valve pressure setting, capacity and date of manufacture. The date code traces the month and year the valve was built. Example: A valve with Serial No. 06B 10, indicates that it was built in June of 2010. See nameplate below for location of data and photo of EZ-SRV replacement cartridge.

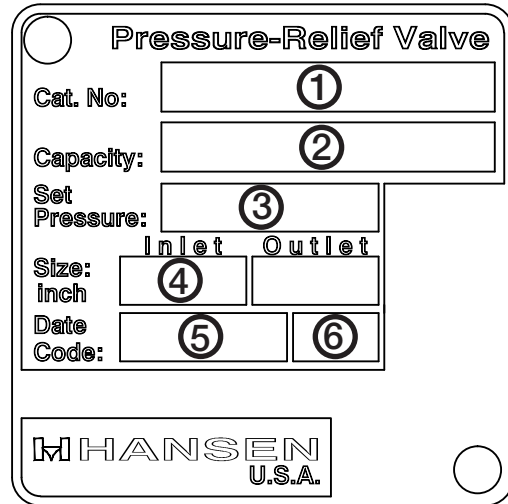

1. CATALOG NUMBER
2. AIR CAPACITY OR LIQUID FLOW RATE ACCORDING TO THE SET PRESSURE
3. SET PRESSURE
4. INLET SIZE
5. MONTH OF MANUFACTURE AND CURRENT REVISION LETTER
6. YEAR OF MANUFACTURE



EZ-SRV Replacement Cartridge

PRESSURE-RELIEF VALVE CAPACITY RATINGS

CAT NO	AIR CAPACITY	PRESSURE SETTING, PSIG (BAR)													
		150 (10.3)	175 (12.1)	200 (13.8)	225 (15.5)	250 (17.2)	275 (19)	300 (20.7)	325 (22.4)	350 (24.1)	400 (27.6)	450 (31.0)	500 (34.5)	550 (37.9)	600 (41.4)
EZA	lb/min	3.6	4.2	4.7	5.3	5.8	6.4	7.0	7.5	8.1	9.2	10.3	11.4	12.5	13.6
	scfm	47	55	62	69	76	84	91	98	106	120	135	149	164	178
	kg/hr	97	112	126	141	156	171	186	200	215	245	275	304	334	363
EZB	lb/min	10.5	12.2	13.8	15.4	17.0	18.6	20.2	21.8	23.5	26.7	30	33	36	40
	scfm	140	162	183	205	226	248	269	290	312	355	398	441	484	526
	kg/hr	286	330	373	418	461	506	549	592	636	724	812	900	987	1075
EZA	lb/min	22	25	29	32	36	39	42	46	49	56	62	69	76	83
	scfm	292	337	382	427	472	517	561	606	651	741	831	920	1010	1100
	kg/hr	598	689	780	872	963	1055	1146	1238	1329	1512	1695	1878	2061	2244
EZE	lb/min	28	33	37	41	46	50	54	59	63	72	82	91	99	108
	scfm	377	435	492	550	608	665	723	781	839	954	1070	1186	1301	1417
	kg/hr	770	888	1006	1123	1241	1359	1477	1595	1712	1948	2184	2419	2655	2890
EZF	lb/min	34	39	44	49	54	60	65	70	75	85	97	108	118	129
	scfm	449	518	586	655	724	793	861	930	999	1136	1274	1412	1549	1687
	kg/hr	916	1056	1196	1336	1477	1617	1757	1897	2038	2317	2599	2880	3160	3441

SELECTION

Step 1: Use the formula below, per ANSI/ASHRAE Standard 15 Safety Standard for Refrigeration Systems, to calculate the minimum required discharge capacity in pounds of air per minute (or kg/s). When selecting a dual pressure-relief valve system, each individual valve must have sufficient capacity to protect the vessel.

$$C = fDL$$

C = minimum required discharge capacity of the relief device in pounds of air per minute (kg/s).

D = outside diameter of vessel in feet (m).

L = length of vessel in feet (m).

f = factor dependent upon type of refrigerant**

Refrigerant	Value of f**
ammonia (R-717)	0.5 (0.041)
R-22, R-134a	1.6 (0.131)
R-404A, R-410A, R-507A	2.5 (0.203)
CO2 (R-744)	1.0 (0.082)

For other refrigerants see ANSI/ASHRAE 15 or contact factory.

** When combustible materials are used within 20 feet (6.1 m) of a pressure vessel, multiply the value of f by 2.5.

Example: To determine the minimum required capacity of a relief valve for a vessel containing ammonia that measures 16 feet (4.9 m) in length and 6 feet (1.8 m) in outside diameter, the equation would be as follows: $0.5 \times 6 \times 16 = 48$ lb-air/min ($0.041 \times 4.9 \times 1.8 = 0.362$ kg-air/s = 1302 kg-air/hr).

Step 2: Determine the pressure setting needed. This should be at or below the design pressure of the vessel. The relief setting should also be at least 25% above the maximum expected operating pressure to avoid “weeping” of relief valves. The setting may be below (never above) the design pressure of the vessel, but it is sometimes best to match vessel design pressure and relief setting to minimize the likelihood of a discharge.

Step 3: Refer to the Pressure-Relief Valve Capacity Ratings above and select the valve with the required capacity (C) at the desired pressure setting.

INSTALLATION

Protect pressure-relief valves from dirt and moisture. Match capacity on valve nameplate to system document as specified by system designer and based upon protected vessel size. Mount valve directly at the vapor space of pressure vessel or on connecting non-valved vapor piping as close to the vessel as possible. (Model EZLQ liquid relief valves can be connected where liquid is to be expected and relieved to a similar or lower pressure, not to exceed the set pressure of the relief valve. Generally, the relief valve is piped around the isolation valve of the protected section or vessel). EZ-SRV™ Cartridge pressure-relief valves should be installed upright.

Never expose your face or body to a connected relief valve exit or piping.

Check that the valve setting and capacity (see Nameplate Information Section) meets the requirements per system design in accordance with local and national regulations. Isolate the valve and related piping from the refrigeration system and pump out pressure to zero before attempting to install or replace any pressure-relief valve. Use appropriate safety equipment. Avoid residual refrigerant when doing so. A gauge valve and gauge can be installed in the inlet pressure port for future use to verify and control any refrigerant which might remain. See also Gauge Valves and Pressure Gauges section on page 6.

Remove shipping caps from the EZ-Fitting. Thread or weld EZ-Fitting into the pressure vessel or three-way dual shut-off valve at a location in the vapor space above the liquid refrigerant level. Install the EZ-SRV™ cartridge pressure-relief valve into the EZ-Fitting and tighten to approximately 75 foot-lbs (102Nm). These valves are for gas relief only. (For liquid relief, Hansen offers the EZLQ relief valve specifically designed for liquid, refer to page 6). Do not install shut-off valves in line with pressure-relief valves. Install valves in locations where they will not be damaged by moving equipment such as lift trucks, etc. Install valves in a manner that enables them to be replaced.

When a dual pressure-relief system is being put into service, the three-way valve stem should be positioned so that only one valve is exposed to pressure. While the three-way valve can be either frontseated (front port is closed) or backseated (back port is closed), the backseated position is recommended because it takes pressure off the packing and reduces the possibility of packing leaks.

Vent the relief valve exit to a safe outdoor location in an approved manner away from people and building openings. Do not install valves or vent piping in a refrigerated space unless precautions are taken to prevent moisture migration into the valve body or the relief vent line. Avoid trapped ice build-up between valves and other equipment.

Only apply thread sealing compound to external pipe threads and use a modest amount to avoid getting compound inside the valve. Use brackets or hangers to support the pipe and prevent the valve from being overly stressed. Do not put undue stress on the valve by using it to stretch or align pipe.

Pressure test all valves and related piping for leaks. When testing a dual pressure-relief system, the three-way valve stem should be in the mid position (only during testing), ensuring that all valves are properly leak tested. Do not discharge valves prior to installation or when pressure testing. Never attempt to reset or change the valve setting. Always replace cartridge pressure-relief valves once they have discharged.

Hansen EZ-SRV™ valves come with an installation date tag to identify the number of years the valve has been in service. When installing the EZ-SRV™ valve, remove the knockouts corresponding to the current year and month. Use a pen to push the knockout partially through the tag and tear away from other side.

Pressure-relief valves for ammonia refrigeration are subject to preventative inspection and maintenance or periodic replacement. Normal replacement is five years from installation. However, once a valve discharges it must be replaced as soon as possible. Self-resetting is not dependable because of the possibility of dirt lodging on the seat surface allowing the valve to leak or “weep”.

REPLACING EXISTING RELIEF VALVES

EZ-SRV™ cartridge pressure-relief valves have the same reduced capacity as the Hansen H5600 series relief valves. The Hansen EZ-Adapter is available to make the inlet and outlet connection dimensions the same as the Hansen H5600 series. This minimizes piping changes to the discharge line connections. The EZ-Adapter provides the same centerline dimensions as an H5600 series relief valve installed with a 2" long nipple. ½" EZ-Adapter, p/n 40-0331. ¾" EZ-Adapter, p/n 40-0332.

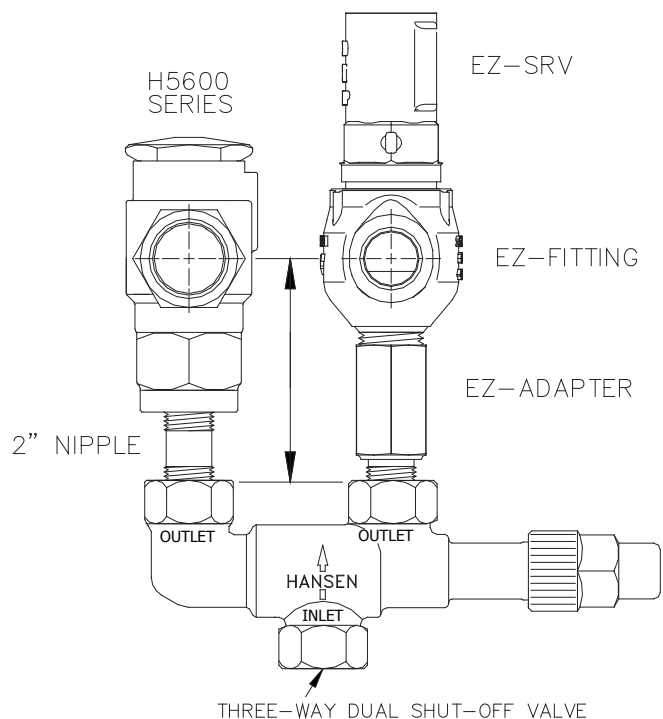

INSTALLATION DIMENSIONS, INCH (MM)

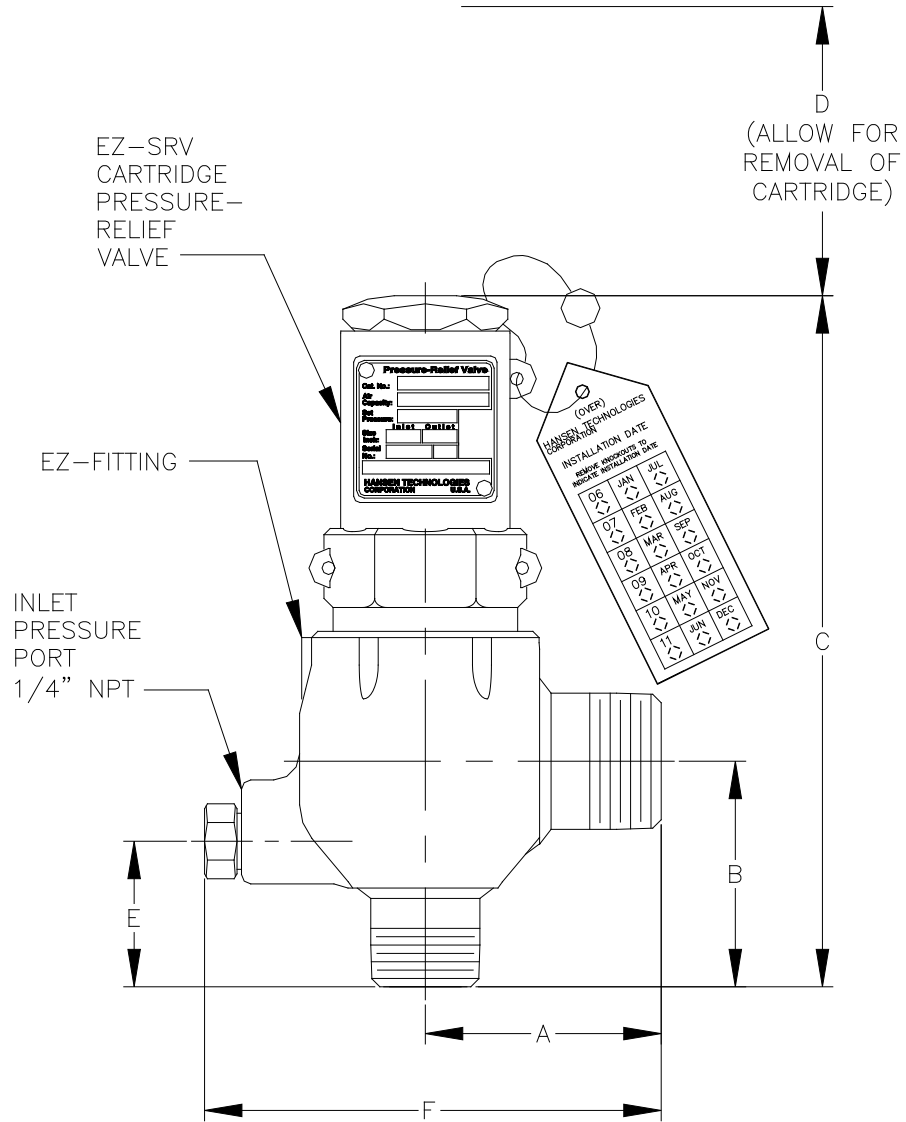

MODEL	A	B	C	D	E	F	W*
EZA, EZB, EZC, EZLQ	2.27 (58)	2.17 (55)	6.65 (169)	2.75 (70)	1.40 (36)	4.62 (117)	2.54 (65)
EZE, EZF	2.72 (69)	2.71 (69)	7.50 (191)	3.00 (76)	1.68 (43)	5.31 (135)	3.14 (80)

*MAXIMUM WIDTH OF VALVE

EZ-FITTING CONNECTIONS	
BT1/BW1	1/2" x 3/4"
BT2/BW2	3/4" x 1"
BT4/BW4	1" x 1-1/4"
BT5/BW5	1-1/4" x 1-1/2"

SERVICE AND MAINTENANCE

These tamper-resistant cartridge pressure-relief valves are accurately factory set and do not require any field adjustments whatsoever. They are intended for one time over-pressure operation and should be replaced immediately after discharging because setting or seat tightness may be altered. Every six months, EZ-SRV™ cartridge pressure-relief valves shall be visually inspected for corrosion or accumulation of scale and for leaks. Removal of the cartridge is not normally required for inspection. Pressure-relief valves should be removed and replaced with new valves at least every five years. Even when simply replacing an existing valve, a review of requirements per current local and national code is advisable. Valves must not be removed unless system has been evacuated to zero pressure.

CARTRIDGE REPLACEMENT

Hansen EZ-SRV™ cartridge pressure-relief valves can be replaced safely and easily. First close the three-way manifold valve to the pressure-relief valve. Slowly bleed the pressure between the three-way manifold valve and the pressure-relief valve to zero pressure. Turn the EZ-SRV™ cartridge two turns to relieve pressure to the discharge piping. Be sure there is no residual pressure and slowly remove the EZ-SRV™ cartridge valve. Clean the interior of the EZ-Fitting especially where the two o-ring surfaces are located. Make sure the EZ-SRV™ cartridge valve setting and capacity (see Nameplate section) match the one being replaced and the requirements of the system design. Lightly oil or grease the o-rings on the replacement EZ-SRV™ cartridge valve and screw into the EZ-Fitting. Tighten to 75 foot-lbs (102 Nm). Wire lugs are provided for optional tamper evident sealing using customer provided locking wire and seal. Next, with a pressure gauge installed on the gauge valve, open the three-way manifold slightly to reach normal pressure. Check for leaks at the EZ-Fitting and EZ-SRV™ cartridge valve joint. Open the three-way valve completely to put the pressure-relief valve back in service.

Punch out the year and month on the installation date tag. The five year replacement date will show on the back.

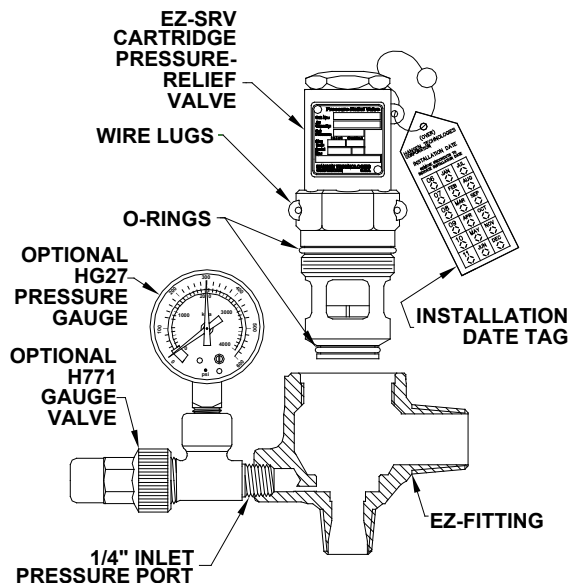

LIQUID RELIEF VALVES

Hansen Technologies offers EZLQ pressure-relief valves for liquid relief applications. Typical applications include ASME vessels, oil coolers and other components that can be isolated by control valves or manual shut-off valves.

Hansen EZLQ liquid relief valves operate on pressure differential. Set points are low differentials of 50, 75, and 100 psid. The equipment the liquid relief valve is protecting must be designed for a pressure greater than the sum of the design operating pressure of the outlet piping plus the differential pressure of the liquid relief valve.

Sizing the capacity of the liquid relief valve depends on the liquid properties and the rate (U.S. GPM) of heating of the liquid. Details on calculating the flow rate are given in the ANSI/IIAR 2-2008 Appendix G and API Standard 520.

Installation and servicing of liquid relief valves may require special precautions. Liquid relief valves should be piped back into the system, not to atmosphere. Appendix M of Section VIII, Boiler & Pressure Vessel Code has general information on installation and service of liquid relief valves.

GAUGE VALVES AND PRESSURE GAUGES

Hansen EZ-Fittings have a 1/4" inlet pressure port and come with a factory installed hex head plug. It is strongly suggested that the port be fitted with an MPTxFPT gauge valve, such as the Hansen H771, to facilitate safer and controlled servicing. The hex head plug should be installed in the gauge valve outlet to prevent accidental refrigerant loss. Alternately, the gauge valve can be fitted with a Hansen HG27 pressure gauge. This compact pressure gauge features a 2" (50 mm) diameter face with an easy-to-read dial. The black needle indicates current sensed pressure, and is useful when replacing a valve, determining which relief valve is active, monitoring vessel pressure, or for general system troubleshooting. The red tell-tale needle indicates the highest pressure as seen by the gauge. This can be useful in identifying which relief valve has discharged or has experienced an abnormally high pressure. The tell-tale needle can be easily reset for monitoring purposes.

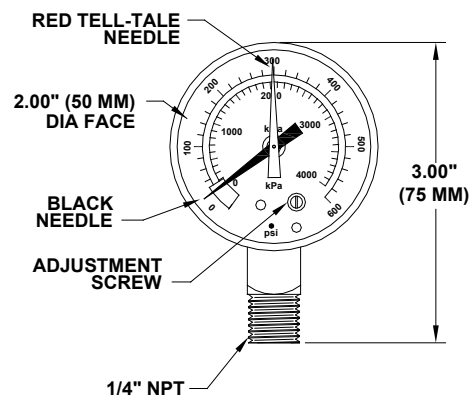

Catalog Number: HG27 Pressure Gauge

Connection: 1/4" MPT

Safe Working Pressure: 600 psig (40 bar)

Scale Range: 0 psig to 600 psig and 0 to 4000 kPa

Ambient Temperature Range: +32°F to +125°F (0°C to +52°C). Contact Hansen for application below +32°F (0°C) ambient temperature.

Suitable for ammonia and other Hansen approved refrigerants.

DUAL PRESSURE-RELIEF VALVES

In accordance with ANSI/ASHRAE Standard 15 Safety Standard for Refrigeration Systems, pressure vessels having 10 cubic feet or more of internal gross volume, shall be fitted with dual pressure-relief valves. This is typically accomplished using a pair of pressure-relief valves interconnected via a three-way dual shut-off valve. Even on smaller vessels this arrangement is often preferred because one valve remains operational, while the other is being replaced; thereby eliminating the need to remove refrigerant from the vessel. Hansen can provide any or all the necessary components, in addition to the actual relief valves, as follows:

THREE-WAY DUAL SHUT-OFF VALVES

These rugged, forged steel bodied valves facilitate the parallel installation of pressure-relief valves. Because three-way valves will not isolate both pressure-relief valves simultaneously, they are considered the only acceptable type of shut-off valve for use with refrigerant relief piping. Their durable metal-to-metal seating and patented non-leak packing plus o-ring stem seal design combine for long, trouble-free service. Inlet and outlet connections are threaded female NPT all the same size.

Shown below is a three-way dual shut-off valve in the stem out position (backseated). The valve stem should be positioned so that only one pressure-relief valve is activated. While the valve can be either frontseated (front port is closed) or backseated (back port is closed), the backseated position (shown) is recommended for normal use because it takes pressure off the packing and reduces the possibility of packing leaks.

THREE-WAY DUAL SHUT-OFF VALVES (SHOWN BACKSEATED)

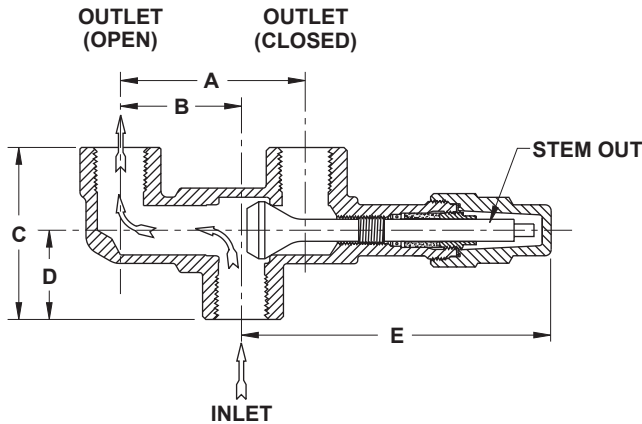

CAT NO	CONNECTION SIZE	DIMENSIONS (INCHES)				
		A	B	C	D	E
H8021	1/2" FPT	3.63"	2.38"	3.38"	1.75"	6.00"
H8022	3/4" FPT					
H8024	1" FPT	5.88"	3.75"	4.00"	2.00"	8.00"
H8025	1-1/4" FPT					

To Order: Specify catalog number and connection size. Three-way valves with SWP 600 psig (40 bar) also available upon request.

RUPTURE DISC ASSEMBLIES

Hansen Rupture Disc Assemblies (RDAs) indicate when a pressure-relief valve has discharged. A pressure-relief valve will reseat after discharging, however a rupture disc remains open after bursting. An installed pressure gauge or switch (required by code) provides a visual or electronic indication that the rupture disc has burst.

Rupture disc assemblies provide a hermetic seal to help eliminate any possibility of minute losses of refrigerant via pressure-relief valve seat materials. Rupture disc assemblies are required when using Hansen pressure-relief valves in halocarbon applications because the high cost of such refrigerants demands extreme tightness. For detailed information on Hansen rupture discs, including ordering and ASME capacity requirements, see Hansen Bulletin K209.

CAT NO	CONNECTION SIZE (MPT X MPT)	PRESSURE SETTING PSIG
RDA1	1/2" x 1/2"	150, 250, 300, 350, 400
RDA2	3/4" x 3/4"	150, 250, 300, 350, 400
RDA4	1" x 1"	150, 250, 300, 350
RDA5	1-1/4" x 1-1/4"	150, 250, 300, 350
RUPTURE DISC ACCESSORIES		
HPS	Pressure Switch, 1/8" NPT	
HG25	Pressure Gauge, 1/8" NPT	
40-0333	1/2" Plated Coupling	
40-0334	3/4" Plated Coupling	

To Order: Specify catalog number, pressure setting, and pressure gauge (HG25) or switch (HPS). Use a rupture disc assembly with the same or lower pressure setting as the pressure relief valve. Rupture discs require use with plated coupling.



EZ-SRV shown with Three-Way Shut-off Valve and optional Rupture Discs, Gauge Valves and Pressure Gauges

ORDERING INFORMATION – EZ-SRV™ REFRIGERANT GAS SERVICE RELIEF VALVES

CATALOG NUMBER (EZ-SRV + EZ-FITTING)		CONNECTION SIZE		EQUIVALENT H5600 SERIES VALVE	REPLACEMENT CARTRIDGE VALVE ONLY
THREADED (MPT)	WELDED (BW)	BOTTOM INLET	SIDE OUTLET		
EZA-BT1	EZA-BW1	1/2" (15 mm)	3/4" (20 mm)	–	EZA
EZB-BT1	EZB-BW1	1/2" (15 mm)	3/4" (20 mm)	H5600R	EZB
EZB-BT2	EZB-BW2	3/4" (20 mm)	1" (25 mm)	H5602R	
EZC-BT2	EZC-BW2	3/4" (20 mm)	1" (25 mm)	H5632R	EZC
EZE-BT4	EZE-BW4	1" (25 mm)	1-1/4" (32 mm)	H5633R	EZE
EZF-BT5	EZF-BW5	1-1/4" (32 mm)	1-1/2" (40 mm)	H5634R	EZF

Standard pressure settings are: 150*, 175, 200, 225, 250*, 275, 300*, 325, 350, 400, 450, 500, 550, and 600 psig. (*Stock pressure settings.) Custom pressure settings (including bar and kPa) and ODS connections are available; contact factory. May require extra delivery time.

To Order: Specify Catalog Number, Pressure Setting, Optional H7771 Gauge Valve and HG27 Pressure Gauge, EZ-Adapter if needed, and accessories. 1/2" EZ-Adapter, p/n 40-0331; 3/4" EZ-Adapter, p/n 40-0332. For halocarbon applications, a rupture disc assembly is required. Refer to page 7 and to Hansen Bulletin K209.

To Order Dual Kits or Dual Union Kits: Add "D" suffix for Dual Kit or "DU" suffix for Dual Union Kit to EZ-SRV™ pressure-relief valve catalog number. Specify inlet/outlet connection size and pressure setting.

Examples: Dual Kit: EZB-BT1D, set at 250 psig; Dual Union Kit: EZC-BT2DU set at 300 psig.

ORDERING INFORMATION – EZ-SRV™ REFRIGERANT LIQUID RELIEF VALVES

CATALOG NUMBER (EZ-SRV + EZ-FITTING)		CONNECTION SIZE		CAPACITY GPM – WATER	REPLACEMENT CARTRIDGE VALVE ONLY
THREADED (MPT)	WELDED (BW)	BOTTOM INLET	SIDE OUTLET		
EZLQ-BT1	EZLQ-BW1	1/2" (15 mm)	3/4" (20 mm)	13 GPM@50 psid 16 GPM@75 psid 18 GPM@100 psid	EZLQ
EZLQ-BT2	EZLQ-BW2	3/4" (20 mm)	1" (25 mm)		

Custom pressure settings and ODS connections are available; contact factory.

To Order: Specify catalog number and pressure setting: 50, 75, or 100 psid.

DUAL/DUAL UNION PRESSURE-RELIEF KITS

Hansen's EZ-SRV™ Dual Pressure-Relief Valve Kit includes: one (1) three-way dual shut-off valve and two (2) EZ-SRV™ pressure-relief valves with EZ-Fittings; available 1/2" and 3/4" inlet sizes. The EZ-SRV™ Dual Union Pressure-Relief Valve Kit consists of: one (1) three-way dual shut-off valve, two (2) EZ-SRV™ pressure-relief valves with EZ-Fittings and two (2) unions for a single outlet; available 1/2" and 3/4" inlet sizes. Unions at the outlets of both pressure-relief valves facilitate field fitting and service testing. Both kits require field assembly. Assembled kits are shown below.

To Order: Add "D" suffix for Dual Kit or "DU" suffix for Dual Union Kit to EZ-SRV™ pressure-relief valve catalog number. Specify inlet/outlet connection size and pressure setting. Examples: Dual Kit: EZB-BT1D, set at 250 psig; Dual Union Kit: EZC-BT2DU set at 300 psig.



DUAL RELIEF KIT



DUAL UNION RELIEF KIT

CAUTION

These instructions and related safety precautions must be read and completely understood before selecting, using, or servicing these valves. Only knowledgeable, trained refrigeration mechanics should install, operate, or service valves. Stated temperature and pressure limits should not be exceeded. Valves should not be removed unless system has been evacuated to zero pressure. See also safety precautions in current List Price Bulletin and Safety Precautions Sheet supplied with product. Escaping refrigerant might cause personal injury, particularly to eyes and lungs.

WARRANTY

Hansen valves are guaranteed against defective materials and workmanship for one year F.O.B. our factory. No consequential damage or field labor is included.

HANSEN

Hansen Technologies Corporation
400 Quadrangle Drive, Suite F
Bolingbrook, Illinois 60440 USA

Tel: 630.325.1565 Fax: 630.325.1572 Toll: 866.4HANSEN

Email: sales@hantech.com Web: www.hantech.com

USA • Asia • Europe • India • Latin America • Middle East

© 2012 Hansen Technologies Corporation