



2" HOTV Oil Temperature Valve

**Specifications, Applications,
Service Instructions & Parts**

**HANSEN OIL
TEMPERATURE VALVE**
1", 1½", 2", 2½", 3"
(25 mm, 40 mm, 50 mm,
65 mm, 80 mm)

for Oil-Cooling Circuits

INTRODUCTION

The Hansen Oil Temperature Valve is a 3-way mixing valve used to accurately control the oil temperature of screw compressors or other oil-cooling circuits within appropriate design parameters. The internal thermostatic element modulates to maintain a near constant temperature at the outlet of the valve.

As oil and refrigerant are circulated through the screw compressor, the oil is heated. The hot oil is fed to the valve and it is also fed to a heat exchanger, which provides cold oil to the opposite side of the valve. The thermostatic element modulates the flow of oil from the cold oil port and the hot oil port to maintain the nominal temperature setting at the outlet.

FLOW RATE VS. PRESSURE DROP

Oil@140°F(60°C) Specific Gravity=0.85

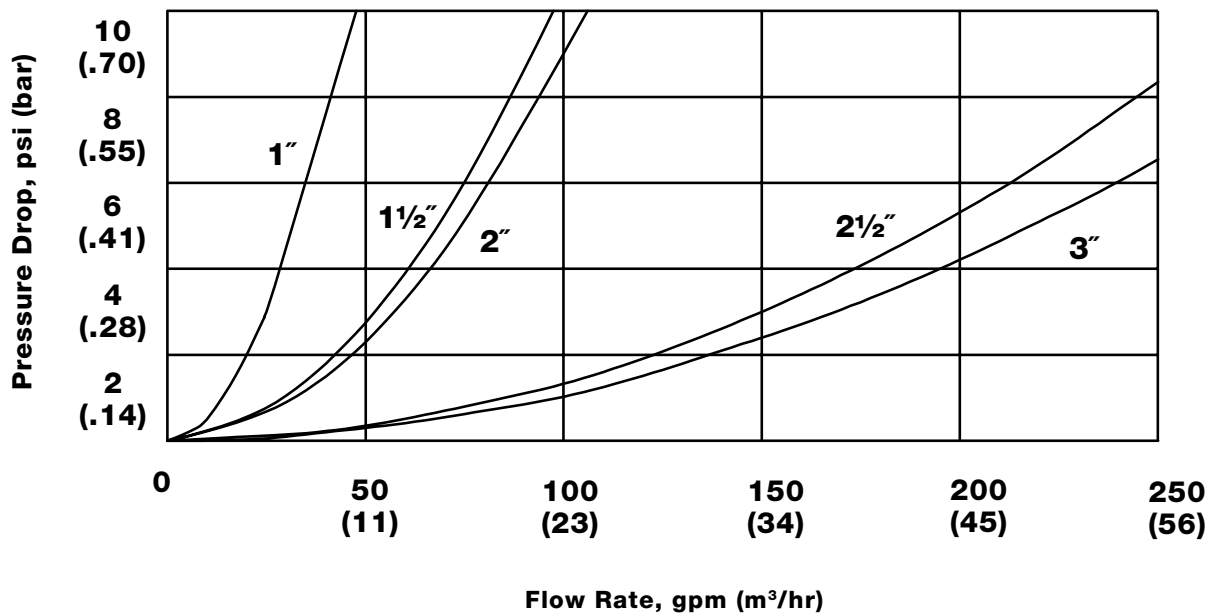

ADVANTAGES

Easy to service—the valve can stay inline
 Durable Teflon® sliding seal is compatible with most refrigerants, oils, and temperatures
 Suitable for mixing or diverting applications

KEY FEATURES

Rugged, all-steel construction, weld ends
 Low pressure drop
 Thermostatic element is stainless steel with a plated sensing bulb
 Suitable for oils operating with ammonia, R22, R134a, and other compatible refrigerants

MATERIAL SPECIFICATIONS

Safe Working Pressure: 400 psig (28 bar) standard, 600 psig (41 bar) available – contact Hansen
 Temperature Range: -60°F to 240°F (-51°C to 115°C)
 Body: 1", Steel, ASTM A36
 Body: 1½"-3", Cast steel, ASTM A352 LCB
 Cover: Steel, ASTM A36
 Sliding Seal: Composite Teflon®
 Cover Gasket: Non-asbestos, graphite composite

Control Temperature Range
 ±10°F (±6°C) of nominal temperature

TYPICAL MIXING APPLICATION

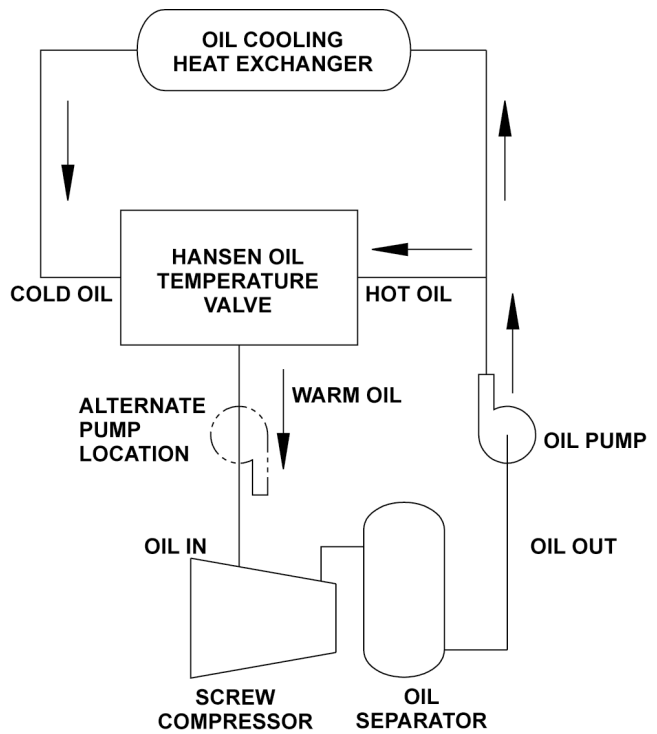

CONFIGURATION SELECTION

1½" SW (40 mm) AND 2" SW OR BW (50 mm)

Two models are available for the 1½" (40 mm) and 2" (50 mm) sizes, HOTV and HOTW. The only difference is the position of the hot oil and cold oil inlets.

TOP VIEW HOTV

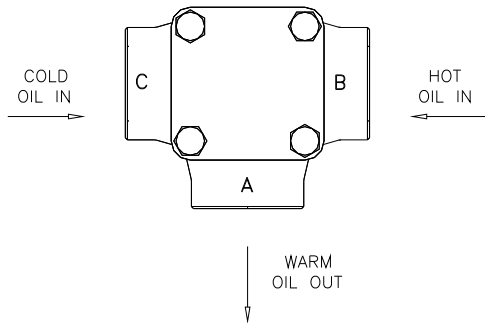

TOP VIEW HOTW

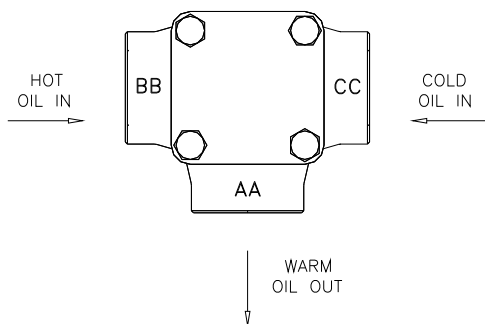

1" SW (25 mm), 2½" SW OR BW (65 mm) AND 3" BW (80 mm)

The 1" (25mm), 2½" (65 mm) and 3" (80 mm) sizes only are available as HOTV models only. The "T-body" style of these valves allows reversal of inlets by simply turning the valve around.

FRONT VIEW HOTV

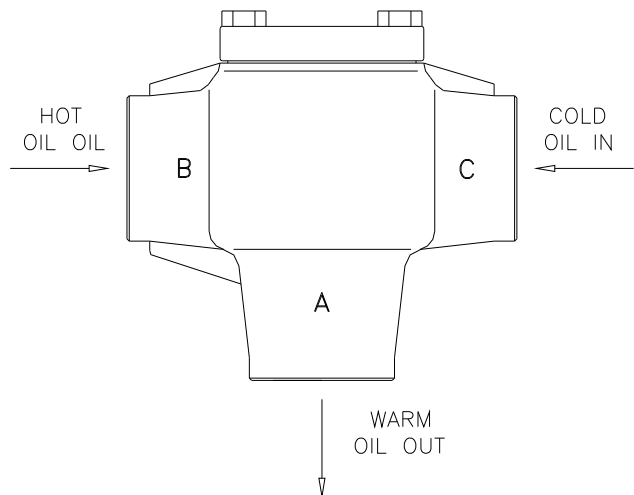

INSTALLATION

Remove the cover and element before welding the valve body in the line. The valve can be mounted in any position. Avoid mounting valve at the high point of the system where a gas pocket may form. After the valve is welded in the line, reassemble it and check for leaks before placing it in service. **NOTE:** Do not remove Teflon sliding seal.

INSTALLATION DIMENSIONS, INCH (mm)

1½" SW (40 mm) AND 2" SW OR BW (50 mm)

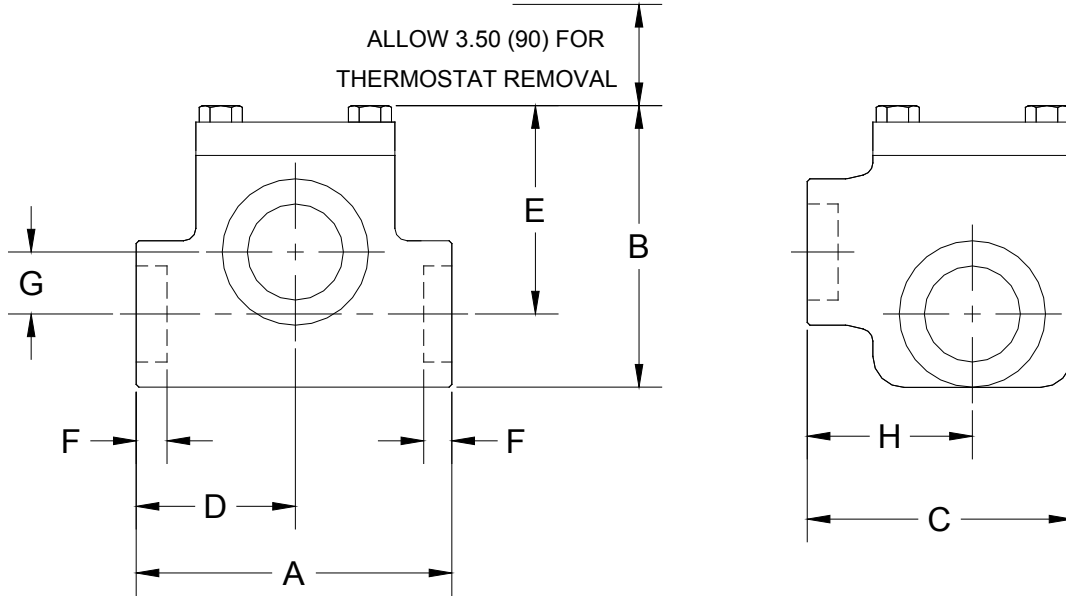

1" SW (25mm), 2½" SW OR BW (65mm) AND 3" BW (80mm)

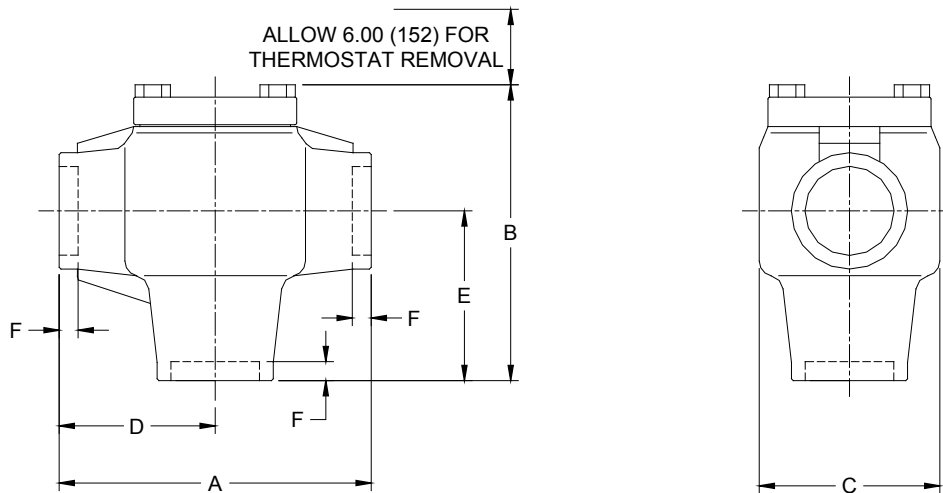

INSTALLATION DIMENSIONS (mm)								
VALVE SIZE	A	B	C	D	E	F	G	H
1" SW (25)	5.28" (135)	5.60" (143)	3.50" (90)	2.64" (68)	3.43" (88)	.50" (13)	—	—
1½" SW (40)	6.40" (163)	5.66" (144)	5.32" (135)	3.20" (81)	4.19" (106)	.62" (16)	1.25" (32)	3.32" (84)
2" SW/BW (50)						.88" (22)		
2½" SW/BW (65)	10.30" (262)	9.75" (247)	5.96" (151)	5.15" (131)	5.60" (142)	.90" (23)	—	—
3" BW (80)						—		

REPLACEMENT PARTS

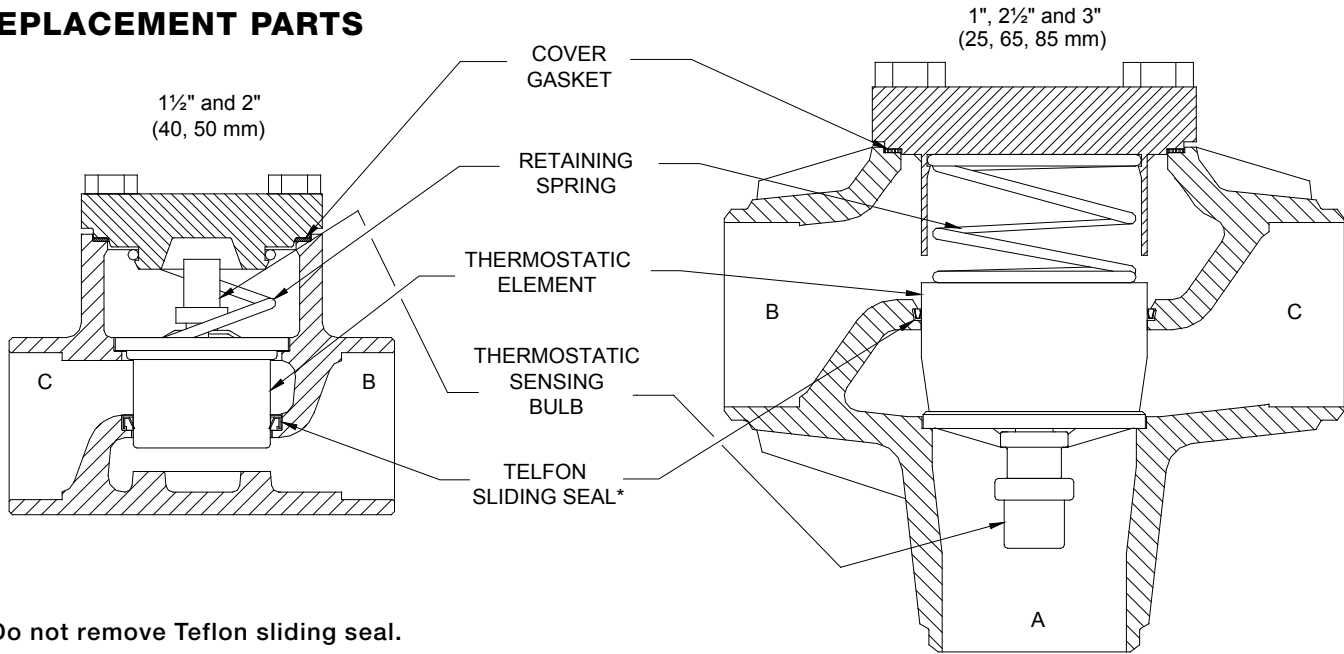

* Do not remove Teflon sliding seal.

SERVICE AND MAINTENANCE

Before opening the valve for service, be sure it is isolated and pumped out to zero pressure. Loosen the cover bolts equally, break the gasket seal, and check for residual oil or refrigerant pressure. Then, remove the bolts. Remove and replace the thermostatic element if necessary. For ammonia service, carefully inspect the thermostatic sensing bulb for nicks or scratches. Plating damage will significantly reduce the life of the thermostatic element. Reinstall the retaining spring. Replace the cover gasket. Reinstall cover.

For 1" (25mm), 1 1/2" (40mm) and 2" (50mm) valves torque the cover bolts equally to 60 ft-lbs (80 Nm), and for 2 1/2" (65mm) and 3" (80mm) valves, torque the cover bolts equally to 125 ft-lbs (170 Nm). Check for leaks before returning the valve to service.

CAUTION

These instructions and related safety precautions must be read completely and understood before selecting, using, or servicing these valves. Only knowledgeable, trained technicians should install, operate, or service these valves. Stated temperature and pressure limits should not be exceeded. Components should not be removed from a system unless it has been evacuated to zero pressure. See also Safety Precautions in the current List Price Schedule and the Safety Precautions sheet supplied with product. Escaping fluids can cause injury, especially to the eyes and lungs.

WARRANTY

Hansen valves are guaranteed for one year F.O.B. our plant. No consequential damages or field labor is included.

ORDERING INFORMATION

To Order: Specify catalog number HOTV or optional HOTW for 1 1/2" (40mm) or 2" (50mm), size, connection style (socket weld or butt weld), and temperature setting. Temperature setting of 120°F (49°C) is standard; See Temperature Selection Chart for other available temperatures.

M100f
FEB 2019

TEMPERATURE SELECTION CHART

CAT NO		SIZE (mm)	TEMPERATURE RANGES							
SOCKET WELD	BUTT WELD		A	B	D	E	F	G	H	
HOTV	-	1" (25)		X	X			X	X	
HOTV	-	1 1/2" (40)	X	X	X	X	X	X	X	
HOTV	HOTVB	2" (50)	X	X	X	X	X	X	X	
HOTV	HOTVB	2 1/2" (65)	X	X	X			X		
-	HOTV	3" (80)	X	X	X			X		
HOTW	-	1 1/2" (40)	X	X	X	X	X	X	X	
HOTW	-	2" (50)	X	X	X	X	X	X	X	

* Consult Factory for other temperatures.

PARTS LIST

THERMOSTATIC ELEMENT REPLACEMENT KIT (Consists of thermostatic element and 1 cover gasket)				
RANGE	NOMINAL TEMPERATURE	PART NUMBER		
		1" (25)	1 1/2" (40) 2" (50)	2 1/2" (65) 3" (80)
H	110°F (43°C)	30-1120	30-1118	-
E	115°F (46°C)	-	30-1122	-
B*	120°F (49°C)	30-1112	30-1104	30-1109
A	130°F (54°C)	-	30-1103	30-1106
D	140°F (60°C)	30-1113	30-1105	30-1119
F	150°F (66°C)	-	30-1117	-
G	170°F (77°C)	30-1115	30-1121	30-1116
Cover Gasket		30-0182	50-0310	30-0083

* Standard (combining Range and Nominal Temp fields to one)

HANSEN
TECHNOLOGIES

Hansen Technologies Corporation
681 Commerce Street

Burr Ridge, Illinois 60527 USA

Tel: 630.325.1565 Fax: 630.325.1572 Toll: 866.4HANSEN

Email: sales@hantech.com Web: www.hantech.com

USA · Asia · Europe · India · Latin America · Middle East

© 2019 Hansen Technologies Corporation