



HCK5D

2-Step Gas-Powered Suction Stop Valve

INTRODUCTION

These heavy-duty, flanged, gas-powered, 2-step suction stop valves are designed to control the flow of refrigerant in large industrial and commercial refrigeration systems. They remain normally open via a spring and require no pressure drop to operate. A single pilot solenoid valve is required to control a higher pressure refrigerant gas which closes these valves during defrosting. The HCK5D valve has an internal, controlled bleed-down (equalize) feature which will not allow the main seat to open until the pressure across the valve is at a lower, safer pressure differential. This eliminates the need for a separate bleed-down solenoid valve, greatly simplifying piping and reducing installation costs. If a loss of power occurs during defrost, evaporator pressure is utilized to keep the main valve seat closed until bleed-down is complete.

APPLICATIONS

The HCK5D valve is ideally suited for positive closure of suction, liquid overfeed, and flooded evaporator gas return lines during defrost in low temperature applications. These valves can be installed in horizontal or vertical lines and are best installed on their sides for improved conveyance of liquid and oil. Because they are gas-powered to close, the valves operate reliably even under viscous oil conditions. They are suitable for Ammonia, Halocarbons, CO₂ and other Hansen approved refrigerants and gases.

ADVANTAGES

The unique self-equalizing piston design eliminates the need and cost for a separate equalizing solenoid valve and piping and associated wiring and controls. A single high pressure source is the only pilot piping required. The main piston/seat opens based on a pressure difference between the evaporator and suction pressure. Bleed rate is adjustable via screw-in orifice discs. The ductile iron body is much stronger and tougher than grey iron or "semi-steel" iron. Protective pilot line disc strainers are included. Manual opening stems are standard for positive opening during servicing or trouble shooting of the systems.

Specifications, Applications, Service Instructions & Parts

**HCK5D
GAS-POWERED, 2-STEP
SUCTION STOP VALVE
1-1/2" THRU 4" PORT
(40 MM THRU 100 MM)**

**Flanged
1-1/2" thru 4"
SW, WN, ODS
for refrigerants**

CRN
Canadian Registration

KEY FEATURES

ACTUATED BY HIGH
PRESSURE GAS

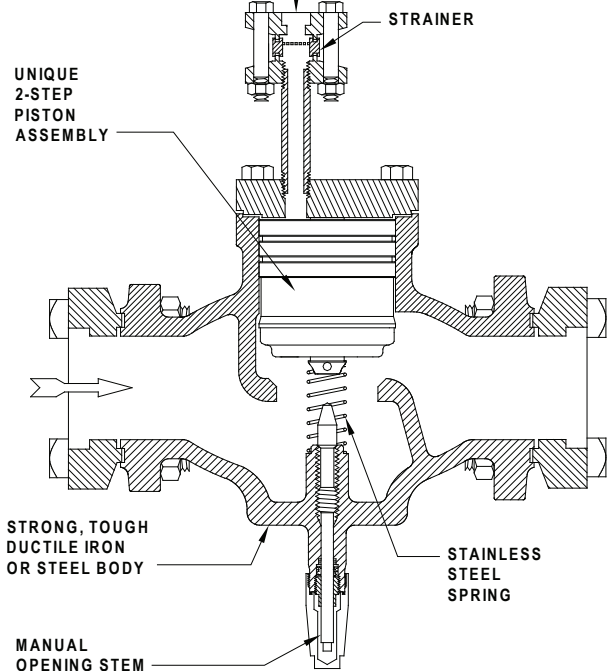

ADDITIONAL FEATURES

- Internal, self-equalizing piston assembly
- Requires only one pilot solenoid valve for operation
- Remains closed until pressure is equalized, during loss of power
- Adjustable bleed rate via orificed plugs
- No pressure drop required to open
- Durable metal-to-metal seating
- Tough ductile iron piston and body
- Lower cost of installation
- Flange-to-flange drop-in for standard Hansen HCK2 Gas powered suction stop valve
- HCK5DW, Weld-In-Line available(contact Hansen)

MATERIAL SPECIFICATIONS

Body: Ductile iron, ASTM A536 (Flanged Valve)

Cast Steel, ASTM A352, grade LCB
(HCK5DW Weld-In-Line Valve)

Top Cover: Steel, ASTM A36

Piston Seat: Ductile iron, ASTM A536

Spring: Stainless steel

Gaskets: Non-asbestos, graphite composite

Stem: Plated steel

Stem Seal: O-ring plus graphite composite packing

Seal Cap: Steel, zinc chromate plated

Companion Flanges: Forged steel ASTM A105

Safe Working Pressure: 400 psig (27 bar), 600 psig (40 bar) for CO₂

Operating Temperature: -60°F to +240°F (-50° to 115°C)

OPERATION

These valves are normally held fully open by means of a spring. When a high pressure refrigerant gas is introduced to the valve through the pilot line inlet, the Upper Piston and Lower Piston are forced down, compressing the Opening Spring and seating the Lower Piston firmly on the valve body taper seat. While the HCK5D is designed to withstand the shock of quick closing, if the noise or system or piping shock is excessive, a lower controlled refrigerant gas pressure may be advisable. Use an outlet pressure regulator, a hand expansion valve, or an orifice.

For valve equalization, the high pressure gas source is interrupted and the upstream pressure raises the Upper Piston while continuing to firmly force the Lower Piston against the valve body taper seat. This allows the refrigerant on the inlet side of the valve to escape in a controlled manner, through four orificed plugs.

The valve will fully open when the downward force on the Lower Piston caused by the difference in pressure between the valve inlet and the outlet is reduced below the upward force due to the compression of the Opening Spring. This typically occurs in the range of 8-12 psi differential. It is advisable to allow ample time for the valve to equalize to a differential

pressure below this range so the valve can open. For most applications 4 minutes should be adequate. If necessary, orificed plugs can be enlarged or removed to decrease bleed down time. Observation in the field may yield a more accurate bleed down time as the valve action is very repeatable.

Because of the constant bleed around the Upper Piston when fully closed, these valves are recommended where closure is for short periods, such as during defrost, or where bleed to suction is not objectionable. When a constant bleed to suction is not desired, use a Hansen HS9B gas powered solenoid valve having a piston seal ring and dual pilot solenoid valves.

INSTALLATION

Protect the interior of the valves from dirt and moisture during storage and installation. These valves may be installed upright or on their sides in either a vertical or horizontal line. The arrow on the valve body should be in the normal direction of refrigerant flow. The System should be free of dirt, weld slag, and rust particles. These valves require only a single pilot solenoid valve to close. A 1/2" (13 mm) port Hansen HS8A solenoid valve with strainer and 3/4" minimum pipe line sizing is recommended to control a high pressure gas source to the HCK5D. (If using a refrigerant liquid for the high pressure source, a Hansen HS9B with bypass gas-powered solenoid valve is recommended, instead of the HCK5D.) The field installed pilot solenoid valve must be connected upstream of any hot gas defrost solenoid valve and should be located as close as possible to the main valve. This will help maintain full high pressure gas to the top of the piston/seat and minimize the amount of high pressure gas to be relieved past the piston/seat upon termination of the high pressure source. Where two HCK5D valves are to be operated simultaneously, a 1/2" port pilot solenoid valve and pilot line strainer assembly should be installed in each pilot line.

For proper flange gasket sealing, care must be taken when threading or welding to ensure flanges are parallel to each other and perpendicular to the pipe. Also, the gaskets should be lightly oiled and all bolts must be tightened evenly.

SUCTION VAPOR CAPACITIES - TONS (KW)

(1 Ton=12,000 Btu/hr=3.517 kW)

APPLICATION		PORT SIZE (MM)				
		1-1/2" (40)	2" (50)	2-1/2" (65)	3" (80)	4" (100)
R717	+20°F (-6.7°C)	58 (204)	68 (239)	110 (387)	156 (549)	341 (1199)
	0°F (-17.8°C)	47 (165)	55 (193)	90 (317)	127 (447)	278 (978)
	-20°F (-28.9°C)	38 (134)	44 (155)	73 (257)	101 (355)	221 (777)
	-40°F (-40.0°C)	29 (102)	34 (120)	55 (193)	78 (274)	171 (601)
R22	+20°F (-6.7°C)	24 (84)	28 (98)	46 (162)	65 (229)	143 (503)
	0°F (-17.8°C)	21 (74)	24 (84)	39 (137)	55 (193)	121 (426)
	-20°F (-28.9°C)	17 (60)	20 (70)	32 (113)	45 (158)	99 (348)
	-40°F (-40.0°C)	14 (49)	16 (56)	26 (91)	36 (127)	80 (281)
Cv (Kv)		47 (40)	55 (47)	89 (76)	126 (108)	276 (236)

Above capacities are based on liquid temperature equal to evaporator temperature and 1 psi (0.07 bar) drop through the valve. For 0.5 psi (0.035 bar) drop, multiply above values by 0.71. For liquid overfeed systems, nominal 2:1 to 5:1 ratio, add 20% to the evaporator load and select a valve based on the increased load. For gravity flooded application, valve should be same port size as properly sized liquid leg or gas line. Consult flooded evaporator manufacturer for proper line sizing.

VALVE SHOWN IN DEFROST (VALVE CLOSED)

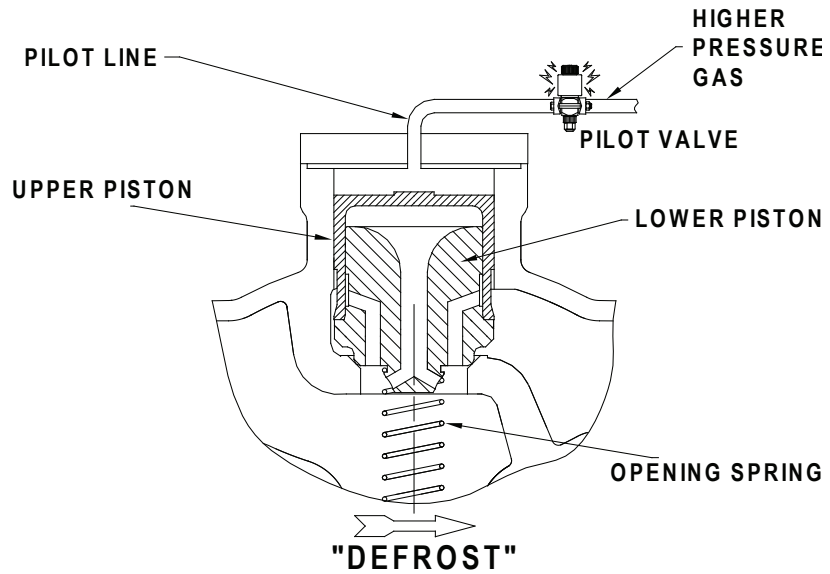

VALVE SHOWN IN EQUALIZATION (BLEED DOWN)

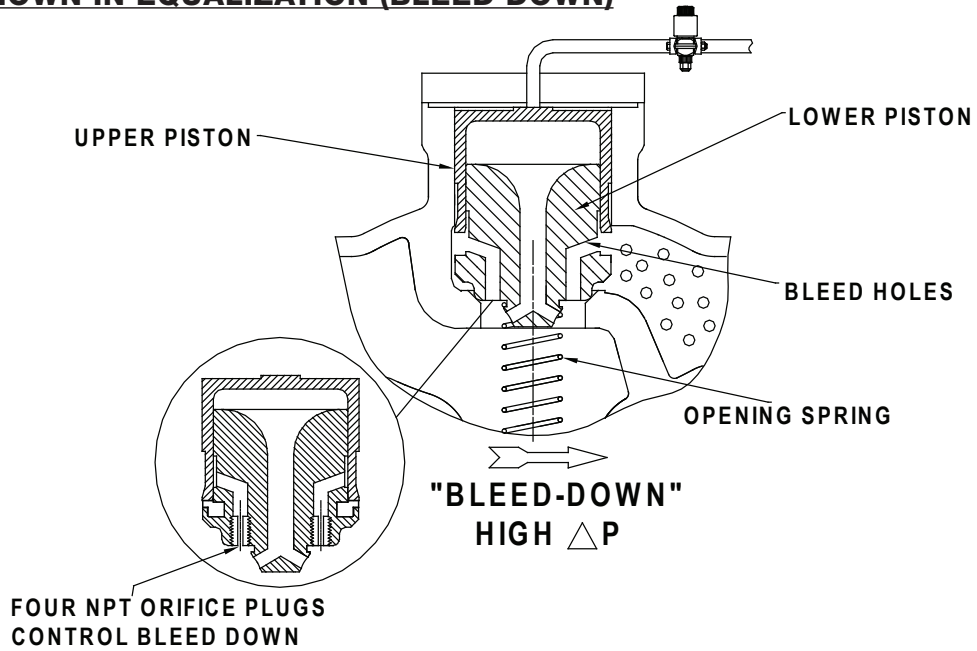

VALVE SHOWN IN REFRIGERATION (VALVE OPEN)

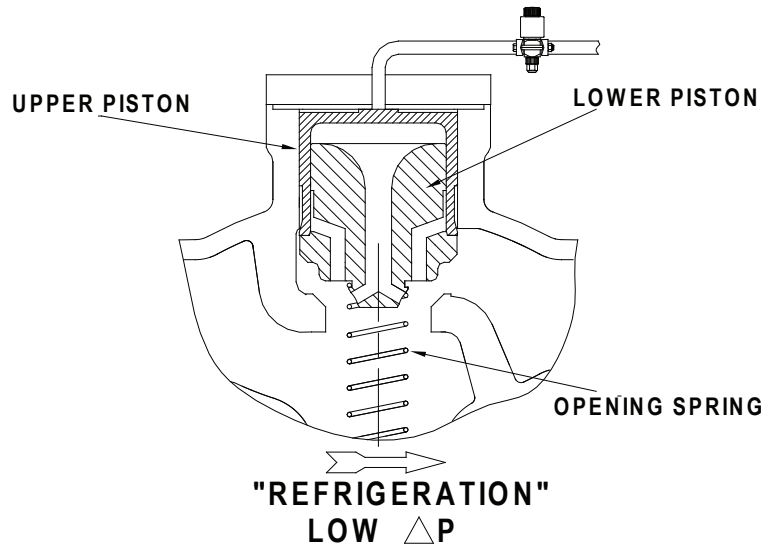

SPECIAL APPLICATION

Flooded Evaporators

Install the HCK5D in the gas leg of the evaporator.
 Use a Hansen HCK2 in the liquid leg of the evaporator,
 installed in the normal direction of refrigerant flow.
 Size the hot gas line for 3/4" minimum when feeding
 two HS8A pilot solenoid valves.

INSTALLATION DIMENSIONS

1-1/2" THRU 4"
 (40 MM THRU 100 MM)

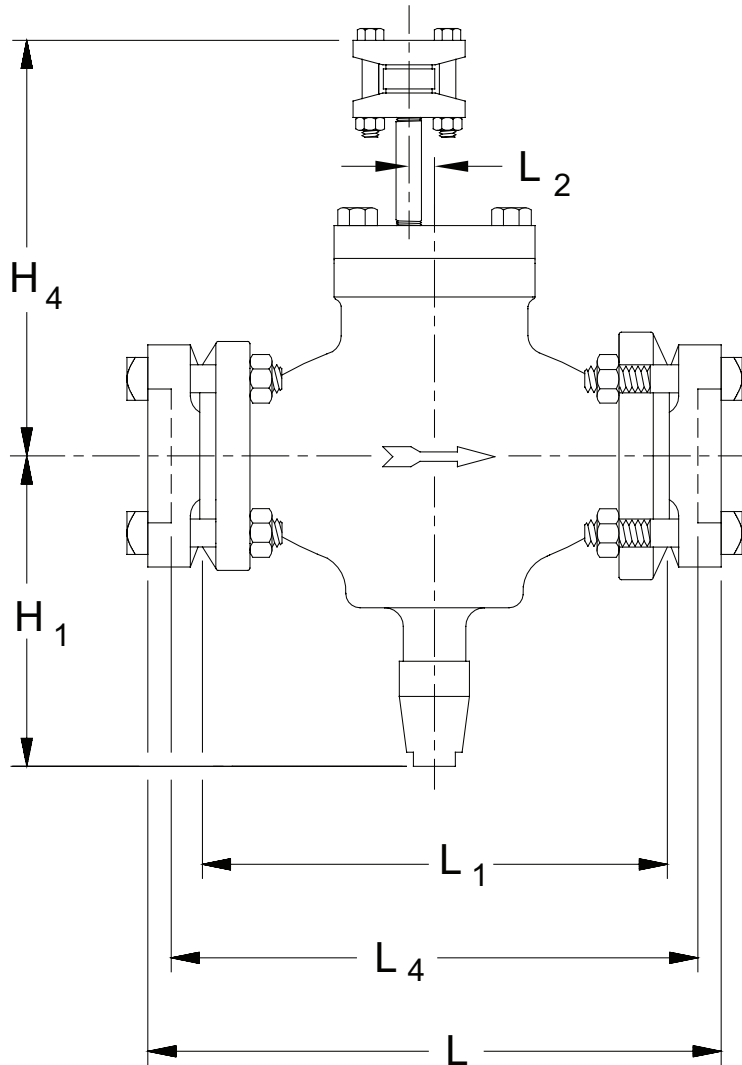

PORT SIZE (MM)	DIMENSIONS (MM)							
	H ₁ *	H ₄	L		L ₁	L ₂	L ₄	W
			SW	WN, ODS				
1-1/2", 2" (40), (50)	7.12" (107)	9.55" (243)	12.39" (315)	13.39" (340)	9.88" (251)	0.86" (22)	10.89" (277)	4.50" (114)
2-1/2" (65)	8.06" (205)	10.23" (260)	13.01" (330)	14.03" (356)	9.88" (251)	1.15" (29)	11.01" (280)	5.62" (143)
3" (80)	8.38" (213)	10.57" (268)	15.38" (391)	16.40" (417)	12.25" (311)	1.15" (29)	13.38" (340)	6.50" (165)
4" (100)	9.88" (251)	11.45" (291)	17.01" (432)	20.51" (521)	14.12" (359)	1.50" (38)	15.01" (381)	8.06" (205)

*Allow additional 2.75" (70 mm) for seal cap removal. W= maximum width of valve.

TROUBLESHOOTING

FAILURE TO CLOSE

- Pilot solenoid valve is not opening due to an electrical problem.
- Disc strainer or high pressure pilot line may be plugged.
- Pilot pressure source may not be high enough. It should be at least 20 psi (1.4 bar) above the pressure through the main valve.
- Manual opening stem is turned in.
- Dirt may have lodged between the upper piston and the valve body piston bore.

FAILURE TO OPEN

- Pilot solenoid is jammed open with dirt.
- Pilot solenoid manual opening stem is turned in.
- Valve differential pressure is not being allowed to fall below 8 psi during bleed down. Increase bleed down time or remove one or more plugs.
- Pilot pressure and pressure through the main valve are not equalizing.
- Check for reverse installation of the main valve.
- Dirt may be lodged between the upper piston and valve body piston bore.
- The opening spring may be damaged or broken.

VALVE NOISY OR CHATTERS

- Pilot pressure gas and evaporator pressure difference is too small. Adjust the defrost relief pressure regulator setting. Check for an undersized pilot solenoid valve (½"HS8A recommended) and/or an undersized hot gas pilot line.

VALVE SLAMS ON CLOSING

- Pilot pressure too high. Replace disc strainer in pilot line with disc strainer/orifice. (Part number 78-0065) or add a hand expansion valve to meter flow.

SERVICE AND MAINTENANCE

MANUAL OPERATION

If it is necessary to manually hold open the HCK5D valve:

- Cautiously remove the seal cap.
- Turn the manual opening stem inward (clockwise) as far as possible.
- The entire piston should be mechanically held open and the valve will not close until the manual opening stem is turned out (counterclockwise).
- Do not operate the HCK5D automatically when the manual opening stem is turned in or else the stem may break after repeated cycles.

LOSS OF POWER

The HCK5D, when used with a normally closed solenoid such as the recommended HS8A, will equalize before opening in the event of loss of power to the pilot solenoid coil.

DISASSEMBLY

If it is necessary to remove or disassemble the valve for servicing, be sure the high pressure pilot line and main valve are completely isolated from the refrigeration system and all refrigerant is removed (pumped out to zero pressure). Be sure to follow refrigeration system safety procedures. Disconnect the pilot line, and clean or replace the disc strainer/orifice assembly as necessary.

To inspect the valve interior, after removing pressure, slowly loosen the cover bolts equally and break the gasket seal, being careful to avoid any refrigerant which may still remain. Remove the cover bolts and cover. Use the tapped hole in the top of upper piston to remove it. Use the same procedure to remove the lower piston. In most cases, the cover bolts can be used. A 5/8"-11 bolt is required to remove the 2" lower piston. Clean and inspect the 4 orifice holes. Verify that the path is clear in each. Clean and inspect the following surfaces for wear and damage:

- Taper seat in valve body
- Contact surfaces of lower piston
- Contact surfaces of upper piston

Slight marks and burrs can often be removed with emery paper by hand or power lapping. Damaged parts should be replaced. After cleaning and inspection, lightly lubricate the interior of the upper piston. Carefully slide the lower piston inside the upper piston. The upper piston should move smoothly on the lower piston and should make good contact with the ductile iron seal surface. Lightly lubricate the main valve interior bore with refrigerant oil and install the spring and piston assembly. Manually simulate valve operation by pushing on top of the piston assembly. Action should be smooth and the spring should readily push the entire piston assembly back. Re-assemble the cover, gasket and bolts, pilot line and disc strainer. Carefully check the entire valve for leaks prior to restoring the valve to service.

BONNET BOLT TORQUE SPECIFICATIONS

PORT SIZE (mm)	BOLT TORQUE FT-LB (Nm)
1-1/2" - 2" (40, 50)	40 (55)
2-1/2" (65)	100 (140)
3" (80)	100 (140)
4" (100)	150 (210)

HCK5D PARTS LIST

1-1/2" THRU 4" (40 MM THRU 100 MM)

ITEM	DESCRIPTION	QTY	PART NO.
	Piston/Seat Kit 1-1/2", 2"		75-1216
	Piston/Seat Kit 2-1/2"		75-1217
	Piston/Seat Kit 3"		75-1218
	Piston/Seat Kit 4"		75-1219
	Above kits consist of:		
1a	Piston Assembly 1-1/2", 2"	1	75-2488
1b	Piston Assembly 2-1/2"	1	75-2486
1c	Piston Assembly 3"	1	75-2470
1d	Piston Assembly 4"	1	75-2499
2b	Opening Spring 1-1/2", 2"	1	75-2462
2c	Opening Spring 2-1/2"	1	75-0195
2d	Opening Spring 3"	1	75-2463
2e	Opening Spring 4"	1	75-2495
3a	Cover Gasket 1-1/2", 2"	1	75-2475
3b	Cover Gasket 2-1/2"	1	75-0093
3c	Cover Gasket 3"	1	75-2461
3d	Cover Gasket 4"	1	75-2496
20	Disc Strainer Flange Gasket	2	70-0065
	Gasket Kit 1-1/2", 2"		75-1220
	Gasket Kit 2-1/2"		75-1008
	Gasket Kit 3"		75-1221
	Gasket Kit 4"		75-1222
	Above kits consist of:		
3a	Cover Gasket 1-1/2", 2"	1	75-2475
3b	Cover Gasket 2-1/2"	1	75-0093
3c	Cover Gasket 3"	1	75-2461
3d	Cover Gasket 4"	1	75-2496
4a	Back-up Washer 1-1/2", 2", 2-1/2", 3"	1	75-0245
4b	Back-up Washer 4"	1	50-0351
5a	Stem O-Ring 1-1/2", 2", 2-1/2", 3"	1	50-0179
5b	Stem O-Ring 4"	1	50-0253
6a	Stem Washer 1-1/2", 2", 2-1/2", 3"	1	50-0046
6b	Stem Washer 4"	1	50-0247
7a	Packing 1-1/2", 2", 2-1/2", 3"	1	50-0045
7b	Packing 4"	1	50-0248
8a	Packing Nut 1-1/2", 2", 2-1/2", 3"	1	50-0013
8b	Packing Nut 4"	1	50-0251
9a	Seal Cap O-Ring 1-1/2", 2", 2-1/2", 3"	1	50-0432
9b	Seal Cap Gasket 4"	1	50-0270
20	Disc Strainer Flange Gasket	2	70-0065
15a	Flange Gasket 1-1/2", 2"	2	75-0138
15b	Flange Gasket 2-1/2"	2	75-0125
15c	Flange Gasket 3"	2	75-0137
15d	Flange Gasket 4"	2	75-0253

ITEM	DESCRIPTION	QTY	PART NO.
10a	Stem 1-1/2", 2", 2-1/2"	1	75-0118
10b	Stem 3"	1	75-0135
10c	Stem 4"	1	75-0242
11a	Seal Cap 1-1/2", 2", 2-1/2", 3"	1	75-0139
11b	Seal Cap 4"	1	50-0260
12a	Cover 1-1/2", 2"	1	75-0107P
12b	Cover 2-1/2", 3"	1	75-0121P
12c	Cover 4"	1	75-0243P
13a	Cover Bolts 1-1/2", 2"	4	75-0175
13b	Cover Bolts 2-1/2", 3"	4	65-0057
13c	Cover Bolts 4"	4	75-0291
14a	Body 1-1/2", 2"	1	75-2446
14b	Body 2-1/2"	1	75-2445
14c	Body 3"	1	75-2447
14d	Body 4"	1	75-2459
16	Flange (SW, WN, ODS)	2	FACTORY
17a	Flange Bolt 1-1/2", 2" (5/8"-11x3.25")	8	70-0135
17b	Flange Bolt 2-1/2", 3" (3/4"-10x3.75")	8	75-0202
17c	Flange Bolt 4" (7/8"-9x4")	8	75-0279
18a	Flange Nut 1-1/2", 2" (5/8"-11)	8	70-0136
18b	Flange Nut 2-1/2", 3" (3/4"-10)	8	75-0210
18c	Flange Nut 4" (7/8"-9)	8	75-0280
19	Orifice Disc Strainer Assembly	1	78-0065
20	Disc Strainer Flange Gasket	2	70-0065
21	Nipple (1/2" x 3.5)	1	75-0677
22	Flange 1/2" SW	2	70-0238
23	Flange Bolt (7/16"-14x2.5")	2	70-0054
24	Flange Nut (7/16"-14)	2	70-0055
25	Flange 1/2" FPT	1	70-0023

HCK5D PARTS LIST

1-1/2" THRU 4" (40 MM THRU 100 MM)

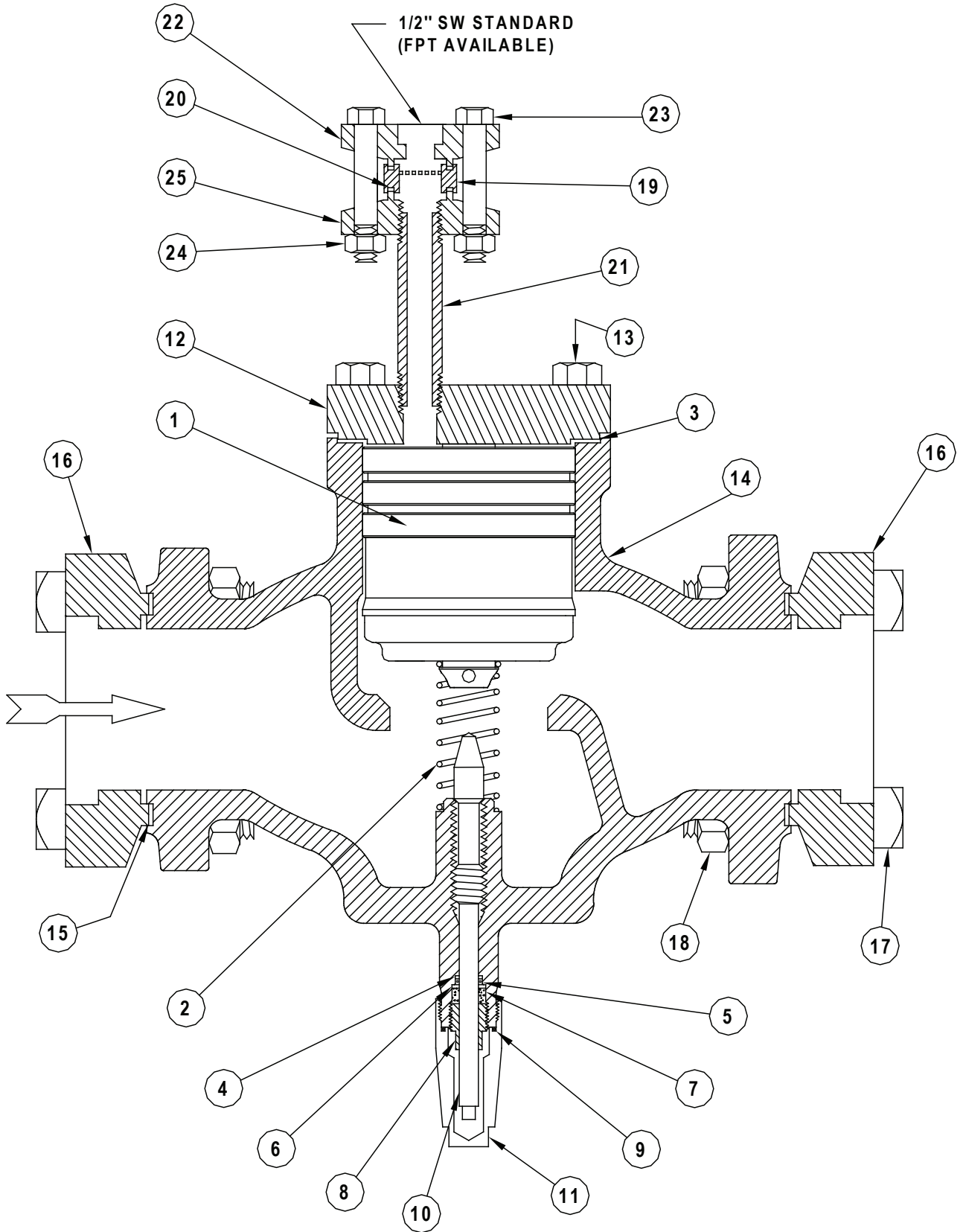

CAUTION

Hansen valves are only for refrigeration systems. These instructions must be completely read and understood before selecting, using or servicing Hansen valves. Only knowledgeable, trained refrigeration mechanics should install, operate, or service these valves. Stated temperature and pressure limits should not be exceeded. Bonnets, solenoid tubes, etc. should not be removed from valves unless system has been evacuated to zero pressure. You must also see Safety Precautions in the current List Price Bulletin and Safety Precautions Sheet supplied with the product. Escaping refrigerant might cause personal injury, particularly to the eyes and lungs.

WARRANTY

All Hansen products, except electronics, are guaranteed against defective materials or workmanship for one year F.O.B. factory. Electronics are guaranteed against defective materials or workmanship for 90 days F.O.B. factory. No consequential damages or field labor is included.

TYPICAL APPLICATION

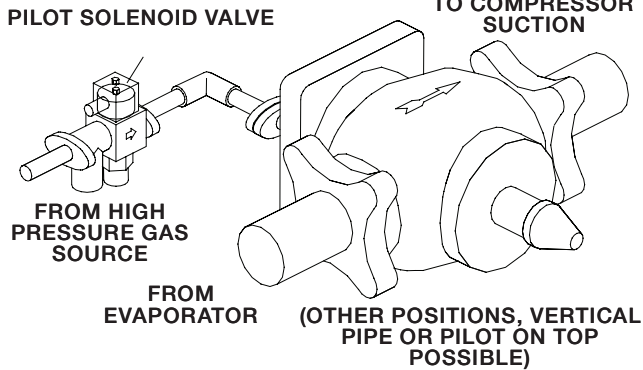

DEFROST CONTROL

Control of the entire defrost process of large, low temperature evaporators, including those using HCK5D Gas-Powered Suction Stop Valves is ideally accomplished by the use of a Hansen Frost Master® or Frost Master® Plus Defrost Controller. In general, the Frost Master® is able to reduce the amount of cold liquid in the coil at the start of defrost, reduce the initial shock of hot gas entry (soft gas), efficiently terminate hot gas stage and to permit the evaporator to return to low pressure with minimum shock to the system and its piping and evaporator.

FROST MASTER® PLUS

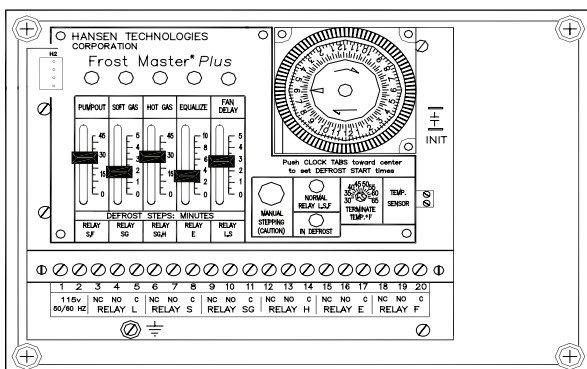

ORDERING INFORMATION

PORT SIZE INCHES (MM)	FLANGE CONNECTION STYLE & SIZES		
	SW, WN		ODS
	STD	ALSO	STD
1-1/2" (40)	1-1/2"	2"	1-5/8"
2" (50)	2"	1-1/2"	2-1/8"
2-1/2" (65)	2-1/2"	3"	2-5/8"
3" (80)	3"	-	3-1/8"
4" (100)	4"	-	4-1/8"

TO ORDER: Specify type HCK5D, port size, flange connection style and size, and pilot solenoid valve if desired. For pilot solenoid valve: specify HS8A for 2" and smaller HCK5D, or HS8A for 2½" and larger; connection style and size: ½" SW standard, FPT or WN available; voltages: 115V, 230V, 24V; 50/60Hz. Unless otherwise specified standard coil with ½" fitting for conduit will be supplied with pilot valve. Also available, DIN plug coil for grounded cord connection or quick disconnect connection.

TYPICAL SPECIFICATIONS

"Gas-powered suction stop valves shall be normally open, 2-step opening, self-equalizing, operated with a single remote pilot pressure solenoid, with manual opening stem, pilot line disc strainer, and suitable for a safe working pressure of 400 psig (27 bar), as manufactured by Hansen Technologies Corporation or approved equal."

HANSEN

Hansen Technologies Corporation
 400 Quadrangle Drive, Suite F
 Bolingbrook, Illinois 60440 USA
 Tel: 630.325.1565 Fax: 630.325.1572 Toll: 866.4HANSEN
 Email: sales@hantech.com Web: www.hantech.com
USA · Asia · Europe · India · Latin America · Middle East
 © 2011 Hansen Technologies Corporation