



2" HCK1 Piston-Type Check Valve

INTRODUCTION

These flanged, heavy-duty, piston-type check valves control the flow of refrigerant. Valves open wide for flow in the direction of the arrow on the valve body. Valves close tight when flow reversals occur. The piston design minimizes pulsations.

Valves open when inlet pressure exceeds outlet pressure (1 psid [.07 bar] minimum), thereby lifting the piston/seat assembly and allowing flow through the valve. When inlet pressure and outlet pressure are equalized, the weight of the piston/seat assembly causes the valve to close. If outlet pressure exceeds inlet pressure, the outlet pressure acting on top of the piston/seat also helps seat the valve closed.

Also available, Type HCK4 in-line check valves and Type SCK combination stop/check valves; contact Hansen.

ADVANTAGES

This normally closed valve requires very little pressure drop to operate. Valve sizes $\frac{3}{4}$ " thru $1\frac{1}{4}$ " have spring-assisted closing. Valve sizes $1\frac{1}{2}$ " thru 6" have a special, spool-type, dirt-resistant piston/seat. A manual opening stem allows positive opening during servicing or troubleshooting the system.

APPLICATIONS

The HCK1 piston-type check valve prevents reverse flow of refrigerant in liquid, discharge, suction, and hot gas lines. It is an ideal valve where constant pulsating of gas or liquid is present, or where a manual opening of the valve is desirable. This valve is suitable for ammonia, R22, R134a, CO2 and other common refrigerants.

Specifications, Applications, Service Instructions & Parts

**HCK1, HCK1W
PISTON-TYPE CHECK VALVE
3/4" THRU 6"
(20 mm THRU 150 mm)**

**Flanged
3/4" thru 4"
FPT, SW, WN, ODS
for refrigerants**

KEY FEATURES

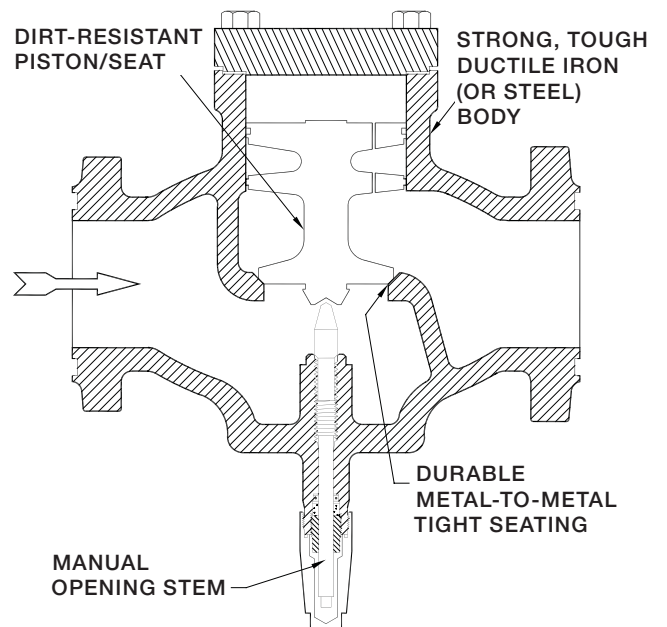

MATERIAL SPECIFICATIONS

Body:

¾" thru 4": Ductile iron ASTM A536.

5" & 6": Cast steel

Piston/Seat:

¾" thru 1¼": Stainless steel with Teflon® seat

1½" thru 6": Ductile iron, ASTM A536

Closing Spring: Stainless steel (¾" thru 1¼" only)

Gaskets: Nonasbestos, graphite composite

Stem: Plated steel

Cover: Steel

Stem Seal: O-ring plus graphite composite packing

Companion Flanges: Forged steel

Safe Working Pressure: 400 psig (27 bar), 600 psig (40 bar) CO₂

Operating Temperature: -25°F to +250°F (-32°C to +121°C)

SIZING

The same care should be taken when sizing check valves as with any other type of control valve. Check valves should be sized so that the valve is fully open under all normal operating conditions. Also, the check valve port size is not always the same as the line size. This is particularly true for gas flow in compressor discharge lines and hot gas lines. Under some conditions, the port size of a properly-selected check valve can be one or two sizes smaller than the line.

The pressure drop across the HCK1 check valve should normally be 2 to 5 psi under full load conditions. In addition, the pressure drop across the check valve at normal minimum load should be determined. For the Hansen HCK1 check valve, a minimum of 1 psi at minimum load is required to ensure that the valve is fully open during all normal flow conditions.

INSTALLATION

Protect the interior of the valve from dirt and moisture during storage and installation. The valve must be installed upright in a horizontal line. The arrow on the valve body should be in the normal direction of refrigerant flow. The system should be free of dirt, weld slag, and rust particles. Install the valve in an accessible location for servicing. Do not install a check valve at the inlet of a solenoid valve or regulator with electric shut-off. Do not install a check valve at the inlet of an outlet regulator where liquid may be trapped between the valves. Check valves in general, when installed, should be at the outlet of control valves to avoid trapping refrigerant between the valves.

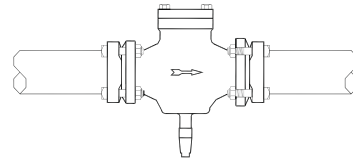

CORRECT

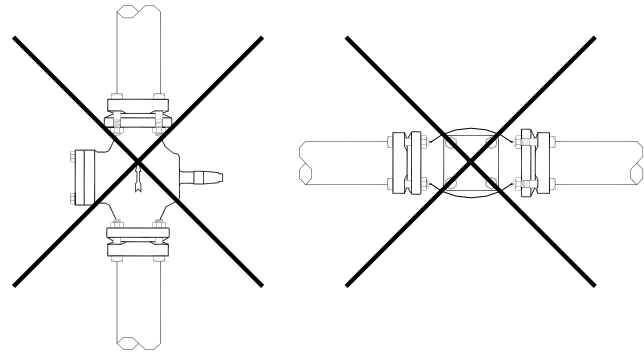

INCORRECT

CAPACITIES

(1 Ton= 12,000 Btu/hr= 3.517 kW= 3042 kcal/hr)

REFRIG	APPLICATIONS		PORT SIZE (mm)										
	DESCRIPTION	ΔP	¾" (32)	1" (32)	1-1/4" (32)	1-1/2" (40)	2" (50)	2-1/2" (65)	3" (80)	4" (100)	5" (125)	6" (150)	
R717	Discharge Line	2 psi	22	29	44	128	150	242	343	750	952	1224	
		5 psi	34	45	69	200	234	378	535	1173	1487	1912	
	Compressor Sideport	2 psi	12	16	25	72	84	136	193	-	-	-	
		5 psi	19	25	38	110	129	209	296	-	-	-	
	Liquid Line	TONS	2 psi	209	274	425	1227	1435	2322	3289	7203	-	-
		GPM	2 psi	14	18	29	83	97	157	222	486	-	-
R22	Discharge Line	2 psi	7.5	9.8	15	44	52	83	118	259	328	422	
		5 psi	12	16	24	70	82	133	189	414	525	675	
	Compressor Sideport	2 psi	4.7	6.2	9.6	27	32	52	74	-	-	-	
		5 psi	7.2	9.5	15	42	50	80	114	-	-	-	
	Liquid Line	TONS	2 psi	48	63	97	282	330	534	756	1656	-	-
		GPM	2 psi	9.9	13	20	58	68	110	156	342	-	-
Cv (Kv)			8 (7)	10.5 (9)	16.3 (14)	47 (40)	55 (47)	89 (76)	126 (108)	276 (236)	350 (300)	450 (385)	

2 psi = 0.14 bar 5 psi = 0.35 bar 1 U.S. GPM (gallons per minute) = 0.227124 m³/hr

Discharge line capacities based on +86°F (+30°C) condenser, +140°F (+60°C) discharge, and +15°F (-9.4°C) evaporator.

Compressor sideport capacities based on +20°F (-6.7°C) economizer and +86°F (+30°C) condensing.

Liquid line capacities based on +20°F (-6.7°C) liquid and +5°F (-15°C) evaporator, with no flashing through valve. To convert to +86°F (+30°C) liquid, multiply values in table by 0.9. To convert R22 capacities to R134a, multiply tons in table by 0.92 (accuracy within 8%). GPM correction factors for temperatures between -40°F (-40°C) and +40°F (+4.4°C) are negligible.

TYPICAL APPLICATIONS

DISCHARGE LINE

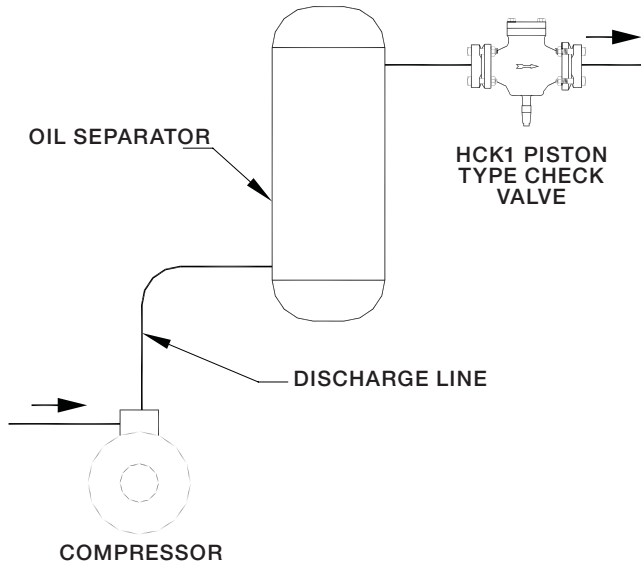

COMPRESSOR SIDEPORT

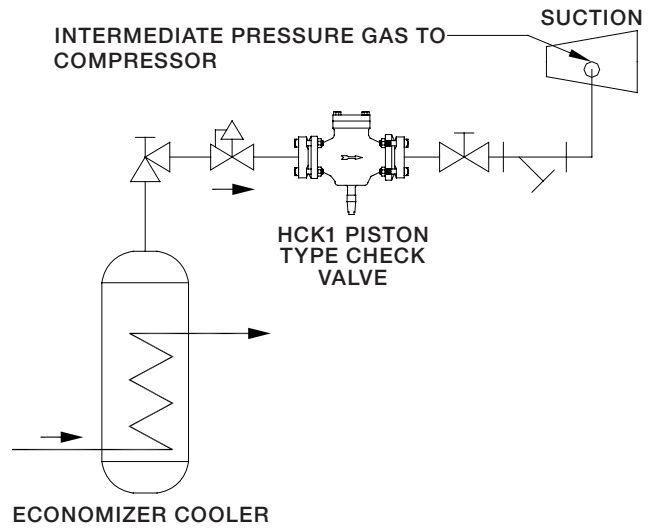

PUMP DISCHARGE LINE

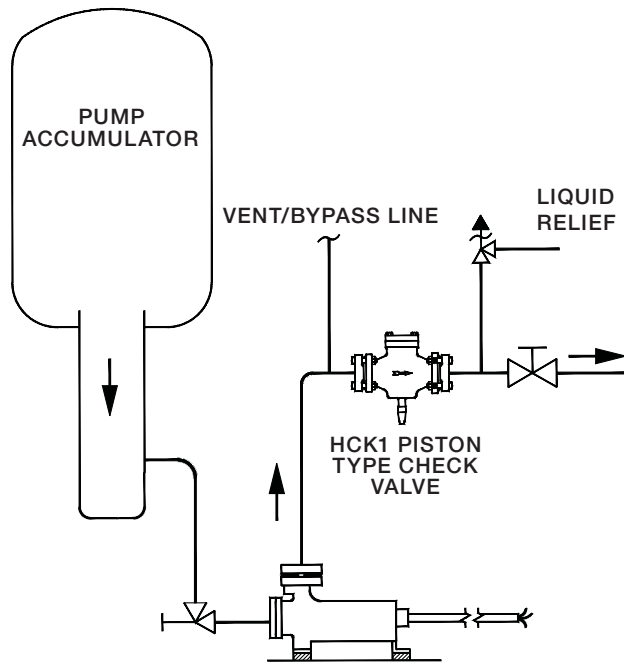

TRANSFER SYSTEM

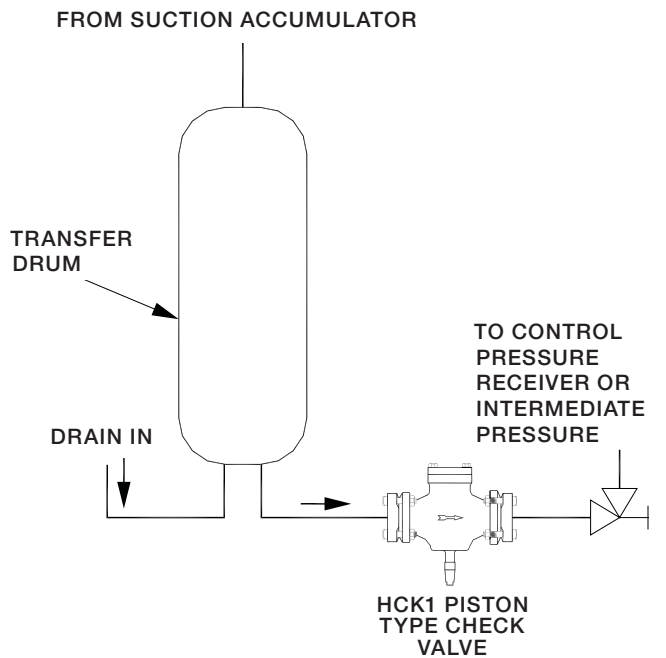

The above are schematic drawings of fictional refrigeration systems to show Hansen product applications in a system. These drawings should not be used for design or construction.

INSTALLATION DIMENSIONS

3/4" thru 4"
(20 mm thru 100 mm)

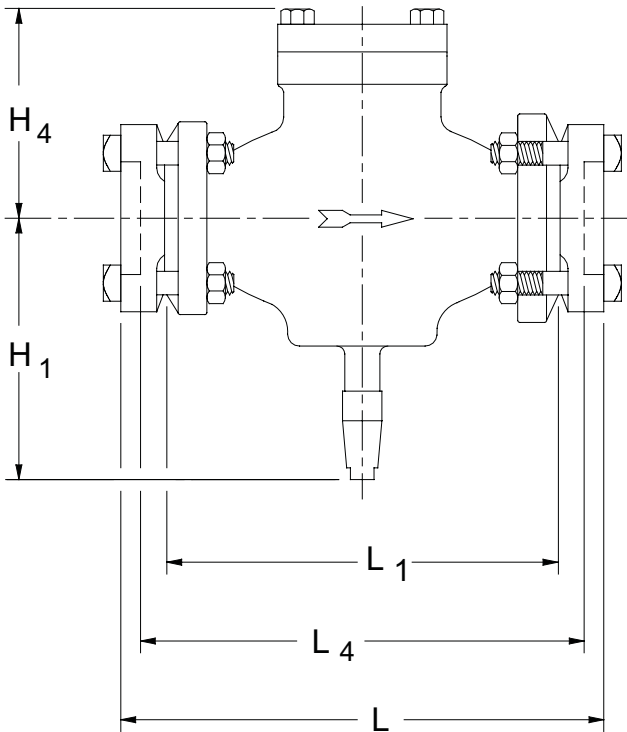

5" & 6"
(125 mm thru 150 mm)

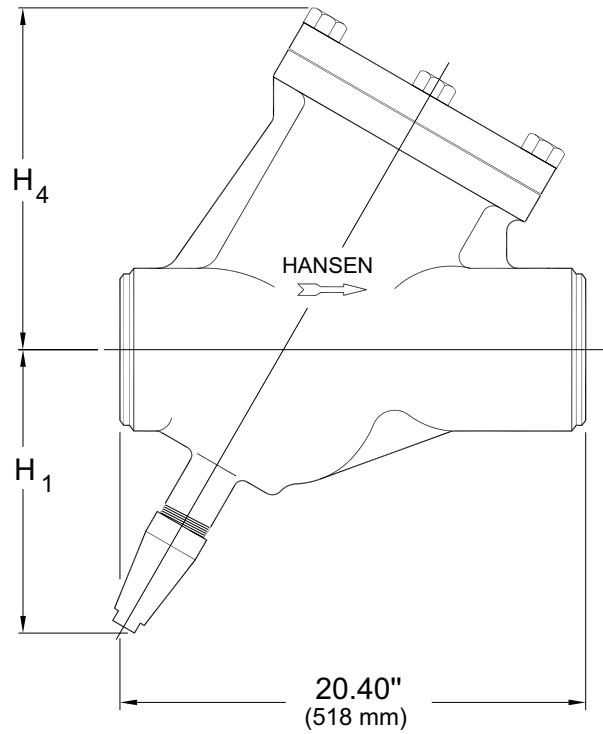

PORT SIZE (mm)	DIMENSIONS (mm)						
	H ₁	H ₄	L		L ₁ *	L ₄	W**
			FPT, SW	WN, ODS			
3/4", 1" (20), (25)	4.21" (107)	8.99" (228)	8.20" (208)	8.94" (227)	6.19" (157)	7.20" (183)	4.50" (114)
1-1/4" (32)	4.21" (107)	8.99" (228)	8.20" (208)	8.94" (227)	6.19" (157)	7.20" (183)	4.50" (114)
1-1/2", 2" (40), (50)	7.12" (107)	5.34" (136)	12.39" (315)	13.39" (340)	9.88" (251)	10.89" (277)	4.50" (114)
2-1/2" (65)	8.06" (205)	6.10" (155)	13.01" (330)	14.03" (356)	9.88" (251)	11.01" (280)	5.62" (143)
3" (80)	8.38" (213)	6.56" (167)	15.38" (391)	16.40" (417)	12.25" (311)	13.38" (340)	6.50" (165)
4" (100)	9.88" (251)	7.38" (187)	17.01" (432)	20.51" (521)	14.12" (359)	15.01" (381)	8.06" (205)
5" (125)	12.13" (308)	14.34" (364)	-	-	20.40" (518)	-	12.75" (324)
6" (150)	12.13" (308)	14.34" (364)	-	-	20.40" (518)	-	12.75" (324)

*L₁ is the flange face-to-face dimension.

** W dimension is the maximum width of the valve.

HCK1 PARTS LIST

3/4" thru 1-1/4" (20 mm thru 32 mm)

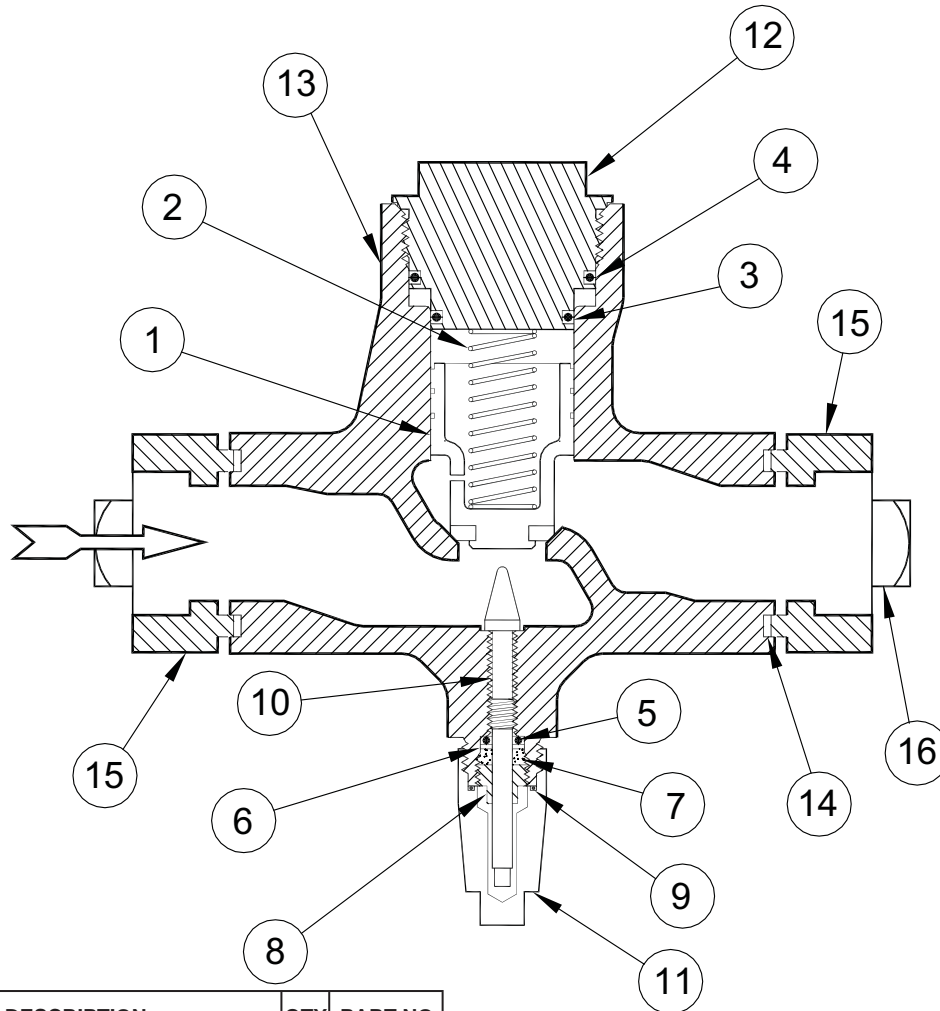

ITEM	DESCRIPTION	QTY	PART NO
	Piston/Seat Kit 3/4"		70-1019
	Piston/Seat Kit 1"		70-1026
	Piston/Seat Kit 1-1/4"		70-0166
	<i>Above kits consist of:</i>		
1a	Piston/Seat 3/4"	1	70-0166
1b	Piston/Seat 1"	1	70-0163
1c	Piston/Seat 1-1/4"	1	70-0167
2	Closing Spring	1	70-0155
3	Cover O-Ring, Lower	1	70-0130
4	Cover O-Ring, Upper	1	70-0131
	Gasket Kit 3/4", 1", 1-1/4"		70-1017
	<i>Above kit consists of:</i>		
3	Cover O-Ring, Lower	1	70-0130
4	Cover O-Ring, Upper	1	70-0131
5	Stem O-Ring	1	70-0010
6	Stem Washer	1	70-0026
7	Packing	1	70-0025
8	Packing Nut	1	70-0019
9	Seal Cap O-Ring	1	70-0011
14	Flange Gasket	2	70-0132
11	Seal Cap	1	50-0411
9	Seal Cap O-Ring	1	70-0011
10	Stem	1	70-0128
12	Cover	1	70-0307
13a	Body 3/4", 1"	1	70-0369
13b	Body 1-1/4"	1	70-0369
15	Flange (various)	2	FACTORY
16	Bolt (5/8"-11x2-3/4")	4	70-0339
17	Nut (5/8"-11)	4	70-0136

HCK1 PARTS LIST

1-1/2" thru 4" (40 mm thru 100 mm)

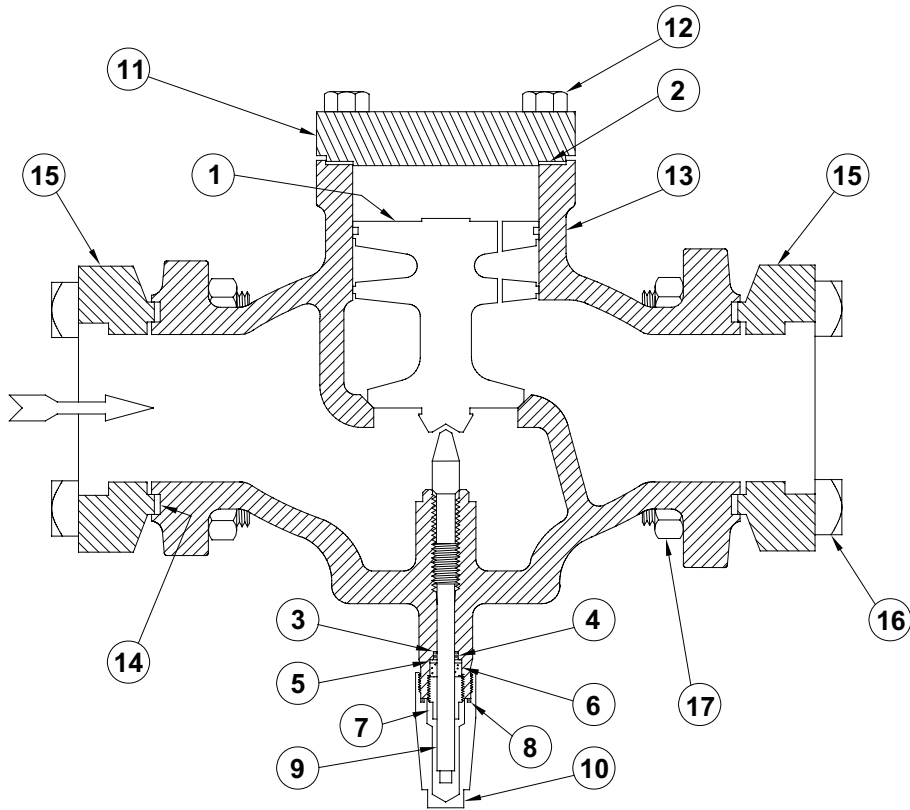

ITEM	DESCRIPTION	QTY	PART NO
	Piston/Seat Kit 1-1/2", 2"		75-1065
	Piston/Seat Kit 2-1/2"		75-1066
	Piston/Seat Kit 3"		?
	Piston/Seat Kit 4"		75-1067
	<i>Above kits consist of:</i>		
1a	Piston/Seat 1-1/2", 2"	1	75-0282
1b	Piston/Seat 2-1/2", 3"	1	75-0281
1c	Piston/Seat 4"	1	75-0244
2a	Cover Gasket 1-1/2", 2"	1	75-0196
2b	Cover Gasket 2-1/2", 3"	1	75-0128
2c	Cover Gasket 4"	1	75-0234
	Gasket Kit 1-1/2", 2"		75-1007
	Gasket Kit 2-1/2", 3"		75-1008
	Gasket Kit 3"		75-1009
	Gasket Kit 4"		75-1017
	<i>Above kit consists of:</i>		
2a	Cover Gasket 1-1/2", 2"	1	75-0196
2b	Cover Gasket 2-1/2", 3"	1	75-0128
2c	Cover Gasket 4"	1	75-0234
3a	Back-up Washer 1-1/2",2",2-1/2",3"	1	75-0245
3b	Back-up Washer 4"	1	50-0351
4a	Stem O-Ring 1-1/2",2",2-1/2",3"	1	50-0179
4b	Stem O-Ring 4"	1	50-0253
5a	Stem Washer 1-1/2",2",2-1/2",3"	1	50-0046
5b	Stem Washer 4"	1	50-0247
6a	Packing 1-1/2",2",2-1/2",3"	1	50-0045
6b	Packing 4"	1	50-0248
7a	Packing Nut 1-1/2",2",2-1/2",3"	1	50-0013
7b	Packing Nut 4"	1	50-0251
8a	Seal Cap O-Ring 1-1/2",2",2-1/2",3"	1	50-0432
8b	Seal Cap Gasket 4"	1	50-0270
14a	Flange Gasket 1-1/2", 2"	2	75-0138
14b	Flange Gasket 2-1/2"	2	75-0125
14c	Flange Gasket 3"	2	75-0137
14d	Flange Gasket 4"	2	75-0253

ITEM	DESCRIPTION	QTY	PART NO
9a	Stem 1-1/2", 2", 2-1/2"	1	75-0118
9b	Stem 3"	1	75-0135
9c	Stem 4"	1	75-0242
10a	Seal Cap 1-1/2",2",2-1/2",3"	1	75-0139
10b	Seal Cap 4"	1	50-0260
11a	Cover 1-1/2", 2"	1	75-0107
11b	Cover 2-1/2", 3"	1	75-0121
11c	Cover 4"	1	75-0243
12a	Cover Bolts 1-1/2", 2"	4	75-0175
12b	Cover Bolts 2-1/2", 3"	4	65-0057
12c	Cover Bolts 4"	4	75-0291
13a	Body 1-1/2"	1	75-0197
13b	Body 2"	1	75-0197
13c	Body 2-1/2"	1	75-0221
13d	Body 3"	1	75-0198
13e	Body 4"	1	75-0238
15	Flange (various)	2	FACTORY
16a	Flange Bolt 1-1/2",2"(5/8"-11x3-1/4")	8	70-0135
16b	Flange Bolt 2-1/2",3"(3/4"-10x3-3/4")	8	75-0202
16c	Flange Bolt 4"(7/8"-9x4")	8	75-0279
17a	Flange Nut 1-1/2",2"(5/8"-11)	8	70-0136
17b	Flange Nut 2-1/2",3"(3/4"-10)	8	75-0210
17c	Flange Nut 4"(7/8"-9)	8	75-0280

HCK1W PARTS LIST

5" & 6" (125 mm thru 150 mm)

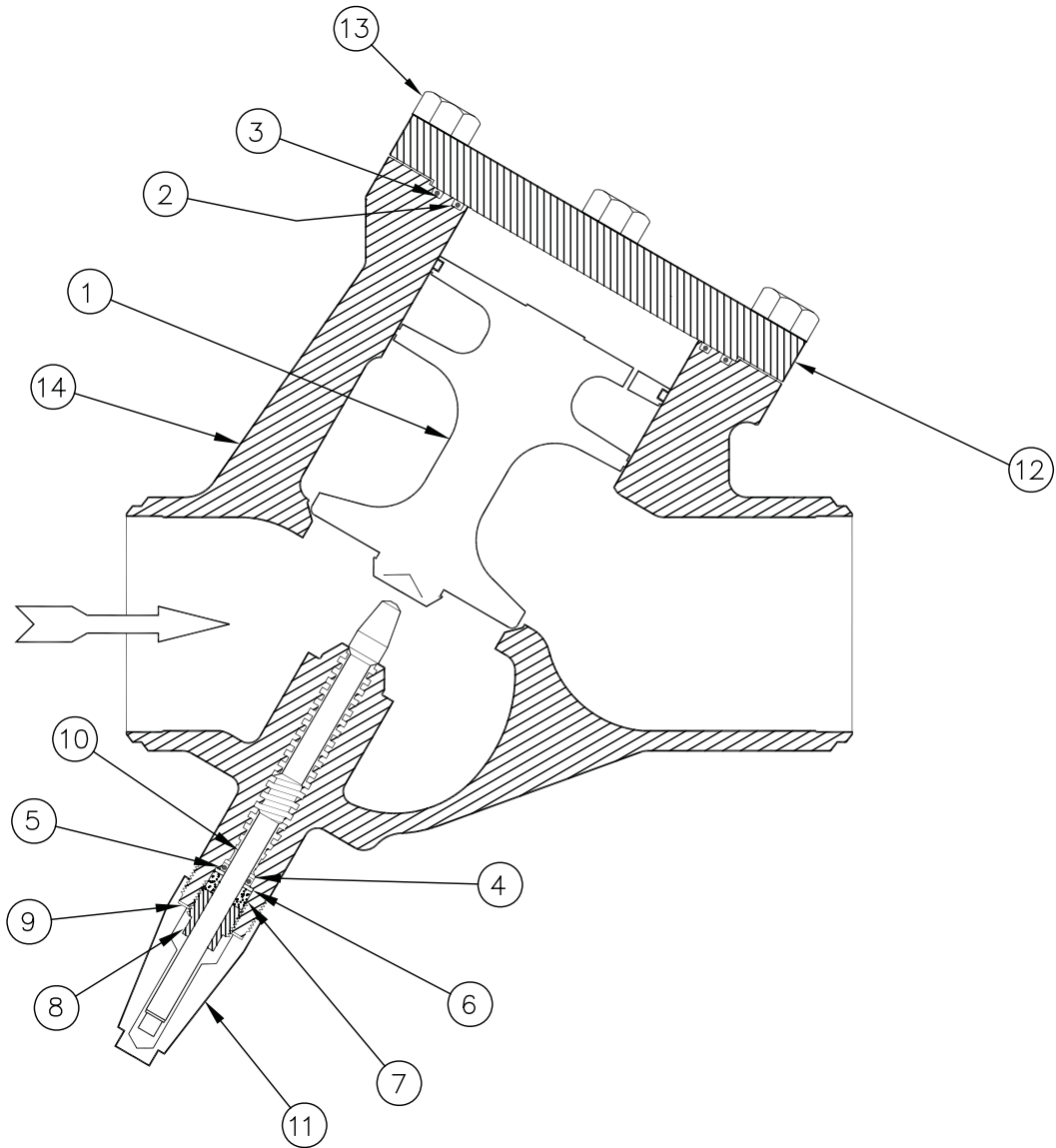

ITEM	DESCRIPTION	QTY	PART NO
1	Piston/Seat Kit 5" & 6"	1	75-1135
2	Cover O-Ring, Inner, 5" & 6"	1	75-0605
3	Cover O-Ring, Outer 5" & 6"	1	75-0606
4	Back-up Washer	1	50-0324
5	Stem Seal O-Ring	1	50-0293
6	Stem Washer	1	50-0299
7	Packing	1	50-0290
8	Packing Nut	1	50-0292
9	Seal Cap Gasket	1	50-0315
10	Stem	1	75-0584
11	Seal Cap	1	50-0304
12	Cover	1	75-0583
13	Cover Bolts	4	75-0604
14a	Body 5"	1	75-0638
14b	Body 6"	1	75-0639

SERVICE AND MAINTENANCE

Failure to Close: The manual opening stem is turned in, mechanically holding the piston/seat open. Dirt may be lodged between the piston/seat and the valve piston wall.

Failure to Open: The pressure difference is not high enough. Inlet pressure must be at least 1 psi above outlet pressure. Adjacent shut-off valves or control valves are not open. Dirt may be lodged between the piston/seat and valve piston wall.

Manual Operation: If it is necessary to manually hold open the HCK1 valve, remove the seal cap cautiously. There may be a small amount of refrigerant trapped in it. Turn the manual opening stem inward (clockwise) as far as possible. The piston/seat is then mechanically held open. The valve cannot close until the manual opening stem is turned out (counter-clockwise).

If it is necessary to remove or disassemble the valve for servicing, be sure it is completely isolated from the refrigeration system and all refrigerant is removed (pumped out to zero pressure). Be sure to follow refrigeration system safety procedures and read the Caution section in this bulletin. To inspect valve interior, slowly loosen the screwed cover or four cover bolts equally, being careful to avoid any refrigerant which may still remain. Remove the piston/seat. Then clean and inspect for burrs and damage to the seating surfaces. Slight marks and burrs can often be removed by hand with emery paper or by power lapping. Damaged parts should be replaced. Lightly lubricate the main valve interior bore with refrigerant oil, and install the piston/seat and closing spring (a closing spring is used in 3/4" - 1 1/4" valves only). Replace the cover, gasket and bolts (1 1/2" - 6"). Carefully check the entire valve for leaks before restoring the valve to service.

CAUTION

Hansen valves are only for refrigeration systems. These instructions must be completely read and understood before selecting, using or servicing Hansen valves. Only knowledgeable, trained refrigeration mechanics should install, operate, or service these valves. Stated temperature and pressure limits should not be exceeded. Bonnets, solenoid tubes, etc. should not be removed from valves unless system has been evacuated to zero pressure. Must also see Safety Precautions in current List Price Bulletin and Safety Precautions Sheet supplied with product.

WARRANTY

All Hansen products, except electronics, are guaranteed against defective materials or workmanship for one year F.O.B. factory. Electronics are guaranteed against defective materials or workmanship for 90 days F.O.B. factory. No consequential damages or field labor is included.

ORDERING INFORMATION

PORT SIZE (mm)	FLANGE STYLE AND SIZES		
	CONNECTIONS AVAILABLE		
	SW, WN, FPT		ODS
	STD	ALSO	STD
3/4" (20)	3/4"	1", 1-1/4"	7/8"
1" (25)	1"	3/4", 1-1/4"	1-1/8"
1-1/4" (32)	1-1/4"	1", 3/4"	1-3/8"
1-1/2" (40)	1-1/2"	2"	1-5/8"
2" (50)	2"	1-1/2"	2-1/8"
2-1/2" (65)	2-1/2"	3"	2-5/8"
3" (80)	3"	-	3-1/8"
4" (100)	4"	-	4-1/8"
5" (125)**	5" BW	-	-
6" (150)**	6" BW	-	-

* 3/4", 1", and 1 1/4" valves are 2-bolt design.

**5" & 6" are integral butt weld only, Type HCK1W.

To Order: Specify Type HCK1 (or HCK1W), port size, flange connection style and size.

TYPICAL SPECIFICATIONS

"Piston-type check valves shall be ductile iron or steel bodied, normally closed, with a manual opening stem, as manufactured by Hansen Technologies Corporation or approved equal."

HANSEN

Hansen Technologies Corporation

6827 High Grove Boulevard

Burr Ridge, Illinois 60527 USA

Tel: 630.325.1565 Fax: 630.325.1572 Toll: 800.426.7368

Email: info@hantech.com Web: www.hantech.com

USA · Asia · Europe · India · Latin America · Middle East

© 2006 Hansen Technologies Corporation