

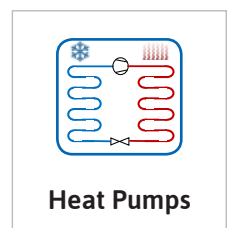

# Product Catalog

2020/2021

**We Increase Uptime, Safety and Efficiency**

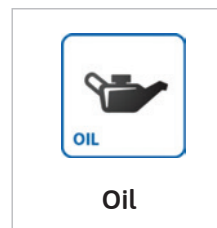
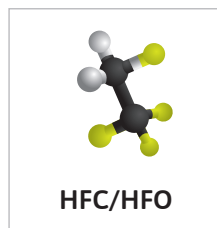
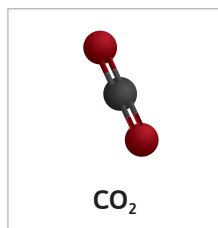
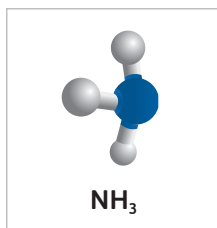

# Introduction

This product catalog is divided into three general sections, which focus on NH<sub>3</sub>, CO<sub>2</sub>, and HFC, respectively. The other six sections are sorted by the function of the sensors. In addition to these sections, you can find introductory information on HB Products A/S, including what we work with, where we are represented, and which standards we are certified to comply with.

At the very end of the catalog, you can find more general technical information, which can be used when you would like to learn more about the terms.

Each of the product sections contains an introductory overview of the products we can offer for the refrigerants. You can find these on the following pages:

Vapor Quality Sensors	19
NH <sub>3</sub> - Ammonia	33
CO <sub>2</sub> - Carbon dioxide	77
HFC/HFO Refrigerants	98
Oil	127
Sensors for Heat Pumps	157
Defrost, Temperature & Pressure	166
Valves	182
Accessories	193

# Table of contents

Introduction .....	2	Oil Switch - 24 V AC/DC .....	129
Our History in Brief.....	4	Oil Switch - 90...240 V AC.....	133
Global Supplier with a Strong Network of Distributors.....	6	Low Temperature Oil Switch - 24 V AC/DC.....	136
Supplier to the Market Leaders .....	7	Low Temperature Oil Switch 90 - 240 V AC .....	139
From Idea to Final Product .....	8	High Temperature Oil Switch - 24 V AC/DC.....	142
General Design Philosophy .....	10	Oil Return Switch - 24 V AC/DC.....	145
Capacitance Measurement .....	11	Oil Level Sensor .....	148
We Serve You - Worldwide.....	14	Oil Management Control Switch.....	151
What Does the Refrigeration Industry Gain from Electronic Components? .....	15	Oil Pot Controller.....	153
Vapor Quality Sensors.....	19	Oil Ejector .....	155
Energy Efficient Evaporator Control.....	20	Sensors for Heat Pumps.....	157
Vapor Quality Sensor in Strainer Housing .....	23	NH <sub>3</sub> Liquid Level Sensor for Heat Pump Applications.....	159
Vapor Quality Sensor, Inline .....	27	High Temperature Oil Switch - 24 V AC/DC.....	163
Vapor Quality Sensor, Angle Rod.....	30	Defrost, Temperature & Pressure .....	166
NH <sub>3</sub> - Ammonia .....	33	Defrost Sensor MK-2 .....	168
Ammonia Plant - Principle.....	36	Ice Bank Sensor .....	172
NH <sub>3</sub> Liquid Level Switch - 24 V AC/DC.....	40	Temperature Sensor .....	173
NH <sub>3</sub> Liquid Level Switch - 90...240 V AC.....	43	Temperature Transmitter/PT 1000 Sensor .....	175
NH <sub>3</sub> Liquid Level Switch - Low temperature.....	45	Cable Temperature Sensor (Without transmitter).....	177
NH <sub>3</sub> /CO <sub>2</sub> Leakage Switch.....	47	Wall Mounted Temperature Sensor with Transmitter.....	178
Ammonia Carbamate detection in Strainer Housing.....	49	Pressure Sensor.....	180
Compressor Protection.....	50	Valves .....	182
Compressor Protection in strainer housing .....	52	Siemens Modulation Valve.....	184
NH <sub>3</sub> Liquid Level Sensor - Wire .....	53	Siemens Modulating Valve .....	187
NH <sub>3</sub> Liquid Level Transmitter .....	58	Carel Stepper Motor Valve.....	190
NH <sub>3</sub> Liquid Level Sensor.....	62	Accessories.....	193
NH <sub>3</sub> Liquid Level Controller .....	66	Sensor Output.....	195
Level Controller.....	69	Oil in Refrigeration Systems .....	202
pH Sensor - Suitable for NH <sub>3</sub> /brine leakage .....	71	Standards .....	208
detection .....	71	HB Online Webshop.....	210
pH Display .....	73		
NH <sub>3</sub> Gas Leakage Alarm/Sensor.....	75		
Carbon Dioxide - CO <sub>2</sub> .....	77		
Two-stage Transcritical CO <sub>2</sub> Plant - Principle .....	78		
CO <sub>2</sub> Liquid Level Switch - 24 V AC/DC.....	81		
CO <sub>2</sub> Liquid Level Switch - 90...240 V AC .....	84		
CO <sub>2</sub> Liquid Level Switch - Low Temperature.....	86		
Liquid Level Sensor - Flex.....	88		
CO <sub>2</sub> Liquid Level Sensor .....	91		
Level Controller .....	94		
CO <sub>2</sub> Gas Leakage Alarm/Sensor .....	96		
HFC/HFO - Refrigerants .....	98		
HFC Liquid Level Switch - 24 V AC/DC.....	100		
HFC Liquid Level Switch - 90...240 V AC.....	104		
HFC Liquid Level Switch - Low Temperature.....	106		
Compressor Protection.....	108		
HFC Liquid Level Sensor - Wire.....	111		
HFC Liquid Level Sensor - Flex.....	115		
HFC Liquid Level Sensor .....	118		
Level Controller .....	121		
F-gas Level Sensor.....	123		
Oil.....	127		

# Our History in Brief

## HB Products - Dedicated to Optimal Solutions

- Evaporator Control and Zero Super-Heat Control.
- Defrost on Demand control solutions.
- Level Measurement and Closed Loop Level Control.
- Safe Oil Management and Oil Return.
- Safety Solutions, Gas-alarm, pH-measurement, NH<sub>3</sub>/CO<sub>2</sub> leakage alarm and alarm for pressure relief in safety valves.

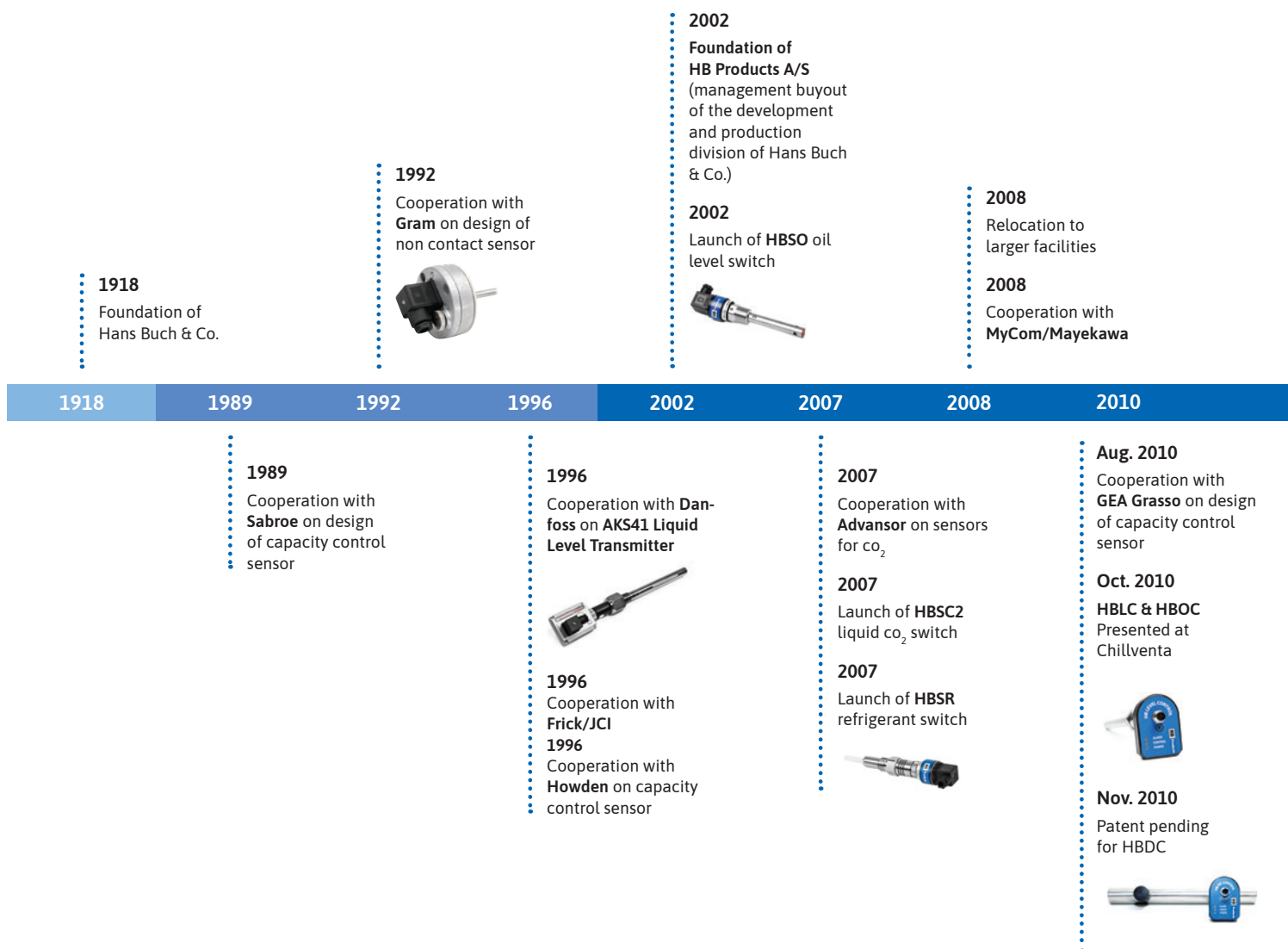

**2018**  
Launch of **HBX Vapor Quality Sensor for CO<sub>2</sub>**



**2018**  
Launch of **Wall Mounted Temperature Sensor with Transmitter HBTS-TR-W** and **HBTS-TR/Cable-2M**



**2019**  
Launch of **HBX Vapor Quality Sensor in Strainer Housing**



**2018**  
Launch of **HBPH-MK2**



**2018**  
Launch of **Oil Ejector HBEJ-MK2**



**2019**  
Complete family of **HBX Vapor Quality Sensors** suited for all types of refrigerants



**2018**  
Launch of **HBLC-Fgas Sensor**



**2016**  
HB X sensors in operation in USA, Australia, The Netherlands, France and Denmark.

**2016**  
HBGS NH3 gas sensor

**2013**  
Cooperation with **Snowkey** on design of capacity control sensor.

2012 2013 2014 2016 2017 2018 2019 2020

**Feb. 2012**  
Field test of **HBDX** in USA

**Oct. 2012**  
**HBDX & CP** Presented at Chillventa



**2014**  
Launch of **HBLT-Wire sensor**



**2017**  
Launch of **Defrost On Demand HBDF-MK-2**.



**2017**  
Launch of **HBTS-TR Temperature transmitter**



**2017**  
Launch of **HBLT-FLEX**



**2020**  
Launch of **HBMD-pH pH Controller & Display**



**2020**  
Launch of **HBMD-L Liquid Level Display**



**2020**  
Expansion of **HB Products' Headquarter** in Denmark



# Global Supplier with a Strong Network of Distributors

We are represented in many countries by local distributors. They are all trained in our products and can support you with both technical issues and with how to best use our products. Today, we are represented in the countries below.

If we do not have a distributor in your country then please contact us directly by email [info@hbproducts.dk](mailto:info@hbproducts.dk) or phone +45 8747 6200.

To find a your local distributor please go to our website: [www.hbproducts.dk](http://www.hbproducts.dk).



# Supplier to the Market Leaders

We deliver advanced sensors to the industry's suppliers of industrial refrigeration systems all over the world.

Here is a list of reference customers:

1. MyCom/Mayekawa
2. Profroid
3. Advansor A/S
4. Emerson
5. Johnson Controls Inc.  
(JCI/Frick/York/Sabroe)
6. GEA Refrigeration Technologies
7. Engie Refrigeration
8. Howden
9. Daikin/McQuay
10. Aerzener Maschinenfabrik GmbH
11. Snowkey
12. Hill Phoenix
13. Dorin
14. Gram Equipment
15. Hanbell
16. Fusheng Group

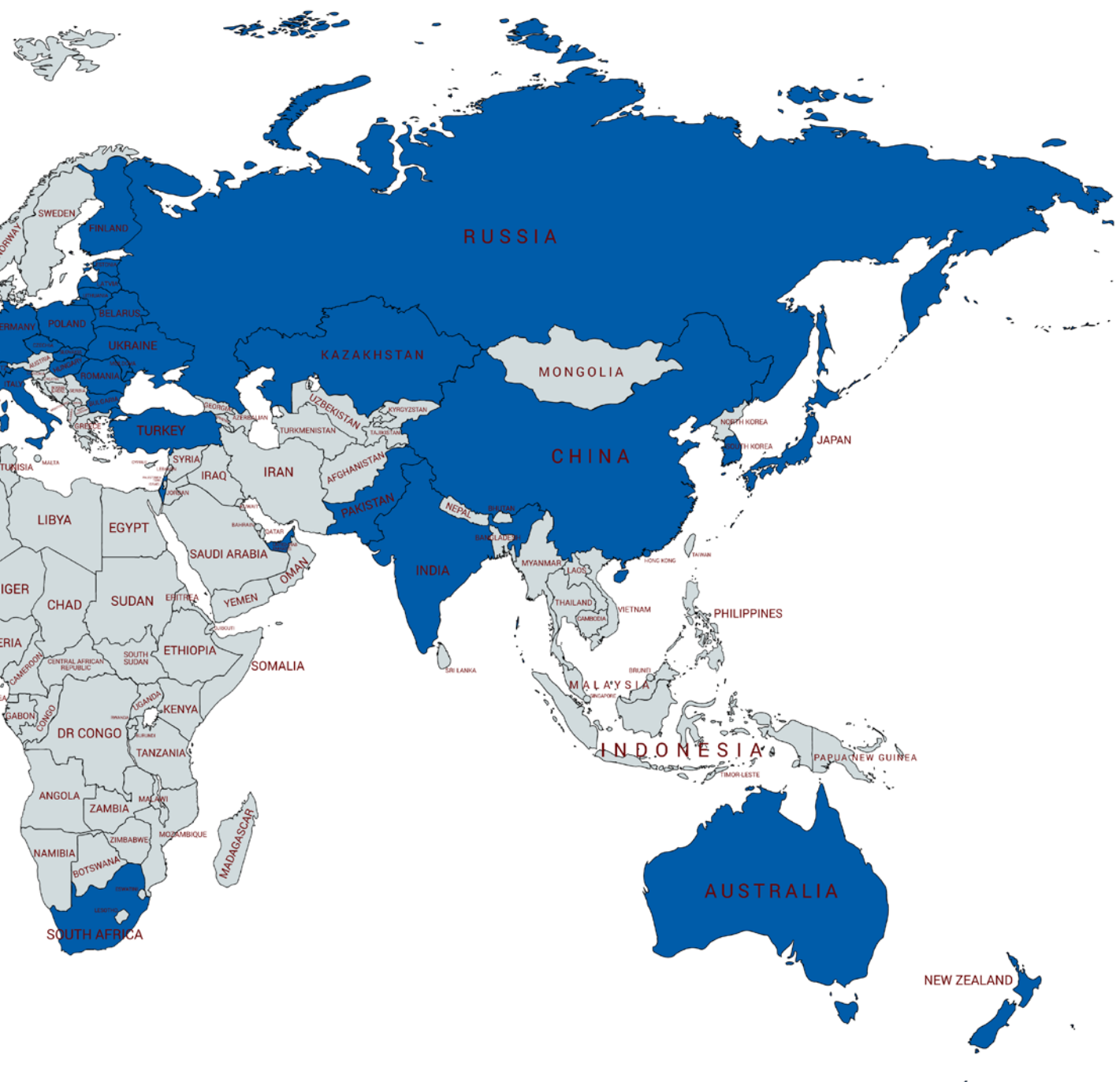

# From Idea to Final Product

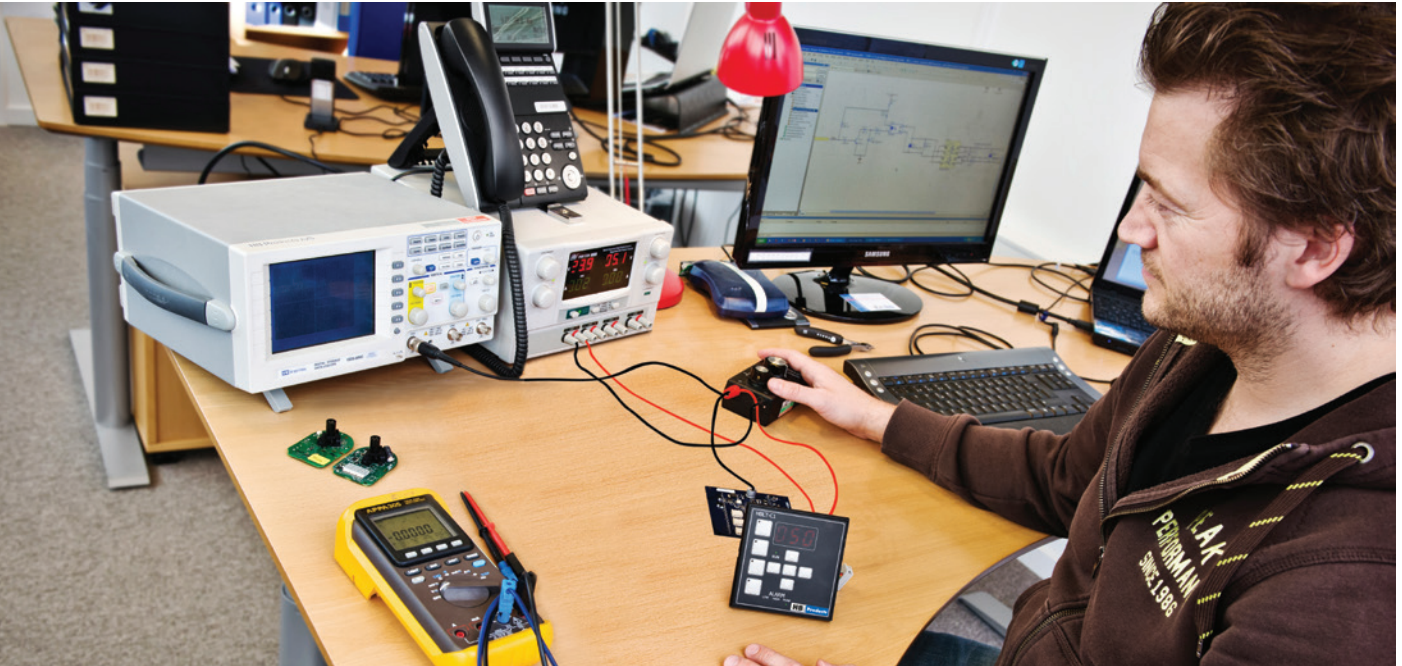

## Development & construction:

HB Products works continuously with the development and design of new products – in new materials and with new functionalities. By using the newest construction tools, the ideas are transformed into new unique products.



## Test and quality control:

All newly developed products go through rigorous testing procedures and extensive quality control before they are cleared up for sale.





## Technology and craftsmanship:

HB Products is responsible for the production of sensors and control modules. In manufacturing, we take a craftsman's approach to our work, but in many areas of production we use modern and highly efficient manufacturing technologies. This ensures high quality down to the smallest detail.

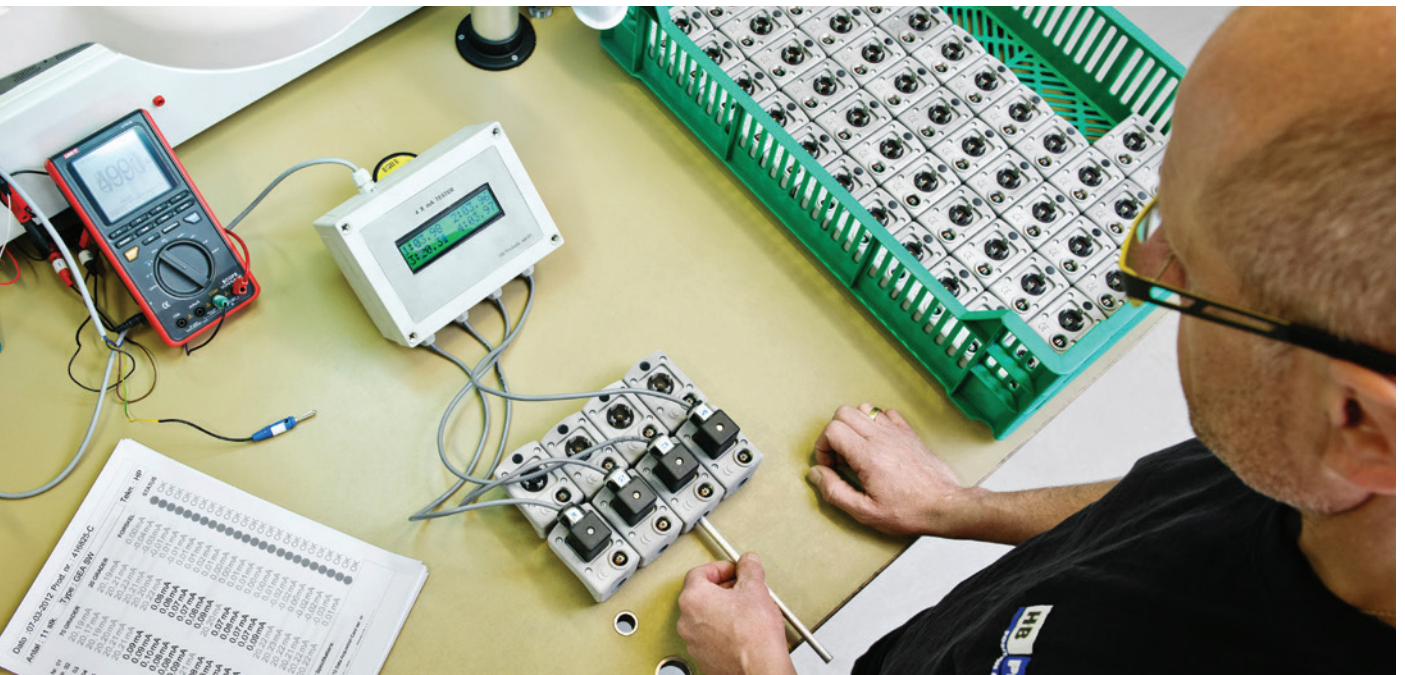

## Calibration:

In order to guarantee products with precise functionality and the best measuring capabilities, each product is calibrated before it is sent to general quality control.

# General Design Philosophy

All products designed for refrigeration applications are designed by refrigeration engineers.

The in-house experience within product development, the electrical design, and the durability of the products makes it very advantageous for customers to use HB Products as a partner for design of reliable products.

Our core competencies ensure trouble-free operating sensors no matter which conditions they are exposed to.

**Our design and production techniques ensure:**



Complete **SEALING** of all electronic parts for reliable functionality in all environments



All sensors are **SHOCK** and **VIBRATION** proof



All input/output are protected against **REVERSE** polarity



All sensors are designed to operate at **HOT** and **COLD** temperatures



All sensors are **INDIVIDUALLY** tested and calibrated



Sensors are designed with **DETACHABLE** electronics for easy service and maintenance



# Capacitance Measurement

## HISTORY

In the late 1940's a British firm pioneered the detection of CAPACITANCE between two electrodes. Capacitance, being influenced by the Dielectric Constant of the material being measured rather than the conductivity, indicated that the concept could be used in virtually any material. A new industry was born.

**HB Products has 20+ years of experience** in the development of electronic sensors, originally for the refrigeration industry, for use with Ammonia (R717), and today we evolved our sensor technology to work with all types of refrigerants even CO<sub>2</sub>.

A capacitor is formed when a level-sensing electrode is installed in a vessel. The metal rod/electrode acts as one plate of the capacitor and the reference tube acts as the other plate. As the level rises, the air or gas normally surrounding the electrode is displaced by liquid having a different/higher dielectric constant. Capacitance instruments detect this change and convert it into a proportional output signal, 0 to 100% level. The capacitance relationship is illustrated with the following equation:

$$C = K (A/D)$$

Where:

C = Capacitance in picofarads "pF"

K = Dielectric constant of the media

A = Area of the inner electrodes

D = Distance between the electrodes

The measured capacitance (pF valve) is converted by the HB sensor electronics into either an analog 4-20 mA output signal or a digital ON/OFF signal. All electronics are factory calibrated to specific fluids.

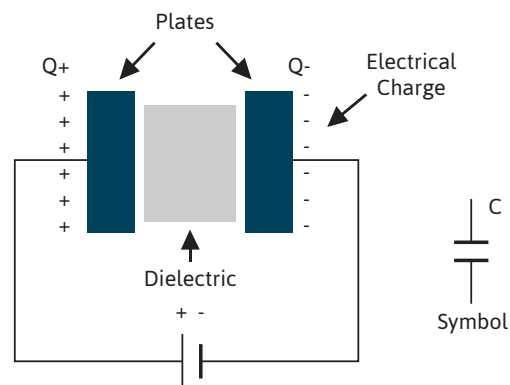

The HBLT-A1 sensor was the first product designed with the capacitive measuring technology. For many years, the sensors were sold by Danfoss under the name AKS41.

The dielectric constant (relative permittivity) is a numerical value, which relates to the ability of the dielectric (material between the electrodes) to store an electrostatic charge. The dielectric constant of a material is determined in an actual test cell. Values for many materials are published. In actual practice, a capacitance change is produced in different ways, depending on the material being measured and the level electrode selection. However, the basic principle always applies. If a higher dielectric material replaces a lower one, the total capacitance output of the system will increase. If the electrode is made larger (effectively increasing the surface area) the capacitance output increases. Level measurement can be organized into two basic categories: the measurement of non-conductive materials and conductive materials.

### Non-Conductive Liquids/Materials

(Nonconductor/insulations as glass, paper, Plastic and Oil) If the dielectric constant is lower than 10, then the material acts as Non-Conductive. ( All HFC/Freon types and CO<sub>2</sub> is Non-Conductive)

### Conductive Liquids/Materials

(Transfer/conduct electric current) If the dielectric constant is higher than 10, then the liquid acts as conductive with a conductivity value at minimum 100 µS/cm (tap water has a value from 500 to 1000 µS/cm). (Water, brine and ammonia are conductive)

**Generally it is not necessary to calculate the actual capacitance, but it is extremely important to understand the principle and how it works. When we design a new capacitive sensor we always base it on practical experience, measurements and tests.**

It is possible to calibrate a level sensor measuring Non-Conductive liquids in water, if you know the exact difference between the dielectric constants.

### Special Considerations

The most devastating effect on the accuracy of capacitive measurements is caused by the buildup of conductive material on the electrode surface. Non-conductive build-up is not as serious since it only represents a small part of the total capacitance. Oil is non-conductive, fine metal powders are examples of materials that are conductive.

### Chemistry effect on the insulating material

The accuracy of the capacitive measurements can be affected by the absorption/swelling of refrigerant (Freon and CO<sub>2</sub>) into the insulating material (PTFE). For the greatest accuracy, the sensor should be recalibrated after the system has operated for a time, when the refrigerant chemistry and level sensor have reached equilibrium. Measuring errors caused by absorption will result in an off set.

HBLC-CO<sub>2</sub> and HFO / HFC liquid level sensors and switches are not affected by chemistry and are therefore long-term stable and do not normally require re-calibration.

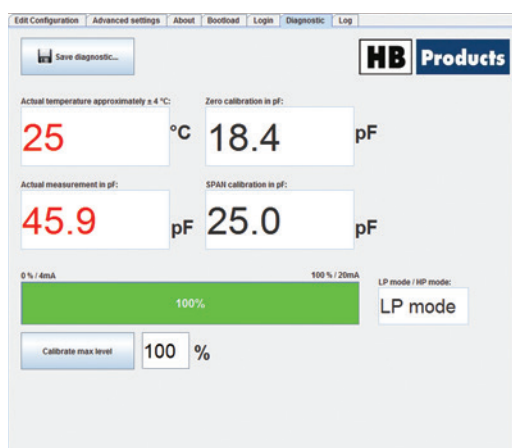

The programmable sensors all have a diagnostic functionality built in, where the actual pF is shown together with the sensor setting, zero calibration and span calibration. Calibration of these are possible on-site.

Dielectric Constant:	Temperature 20°C
Water/brine	80 (88 @ 0°)
Ammonia (R717)	17 (22 @ -40°)
CO2 (R744)	1.5 (2.0 @ -40°)
Oil type PAO, POE	2.2 Mineral and synthetic types
Oil type PAG	3.5 Synthetic types
R134a	9.24
R22	6.35
R410A	7.78
R404A	7.58
R407A	8.74
R507	6.97
HFO R1234ZE	7.76
HFO R1233ZD	3.86
Air	1.0
Ice	3.2

The dielectric constant of the material/liquid varies depending on type. If two or more liquids are mixed, this will also result in a change of the dielectric constant. For example, a small quantity of water will change the dielectric constant for R507.



The Vapor Quality Sensor is the first sensor in the world capable of measuring vapor quality in a refrigeration system. The sensor has a 4-20 mA output signal, linear with the vapor quality.

# We Serve You - Worldwide



HB Products is represented by a growing number of distributors all over the world. Our criteria for selecting business partners guarantees the customers professional and qualified consultancy and support - locally.

All our business partners are specialists within consultancy for components used in refrigeration systems. It is our intention, as well as the intention of our business partners, to keep a wide variety of sensors in stock; however, since these come in countless variants, we hope that you understand that they cannot all be kept in stock.

In the countries/regions where we do not yet have local business partners, enquiries must be sent to us.

## Quality control and certification

HB Products and a number of our product series are certified, including our OEM products.



ISO 9001:2015 - Since 2004 we have been ISO 9001 certified

This certification demonstrates our serious approach towards the products we develop, produce, sell, and service.



IECEX Protection Class: Ex ib IIC T5



cULus Protection Class: Class I,

Division 2 Group ABCD Hazardous



ATEX Protection Class: EEX ib iiC T5 acc.

To DIN EN 50020 – IEC 79-11-ANSI/UL 2279, pt.11

# What Does the Refrigeration Industry Gain from Electronic Components?

There is a great potential for energy and optimization of operations in the refrigeration industry. The natural way is using new technologies, implementation of intelligence as well as making gradual improvements in the refrigeration process, such as avoiding oil, air and water in places where these should not be. This article focuses on sensors as the first step towards the optimization of refrigeration plants. Similar to the automotive industry where sensors have been essential in cars, likewise sensors are essential for an optimized regulation of refrigeration plants within the refrigeration industry. Furthermore, sensors allow new possibilities as they may be successfully adjusted to specific applications.



From the very beginning, the industrial refrigeration industry has been characterized by mechanical solutions and has remained unchanged until today. Compared to the commercial refrigeration industry, the volume of the industrial refrigeration industry on a global scale is considerably smaller and may be seen as a niche market.

A very long time ago, the personnel were responsible for the service of plants, i.e. checking of liquid indicators, oil level, manometers, etc. Today, there is a strong financial incentive to optimize monitoring of plant operations in one display. It is also preferred that the plant operates 100% automatically: it closes down automatically in case of safety precautions or turns on an alarm if the plant requires inspection or maintenance. Here the electronic sensors are essential.

## A short insight into the history of industrial refrigeration branch

The first types of instruments used in the refrigeration branch were a mechanical pressure sensor, thermometers, liquid indicators as well as mechanical/electrical switches. Later, the mechanical pressure sensor was replaced with electronic pressure transmitters, thermometers by electronic temperature displays, whereas liquid indicators were replaced with level sensors. During the last 15-20 years, the mechanical/electrical switches are gradually being replaced by electronic ones.

Some of the first mechanical solutions are still being widely used today. They are simple and do not require adjustment to other components.

## What are the limitations of mechanical solutions?

Mechanical solutions have their limitations! The greatest disadvantage related to optimization is that they are not able to transmit a signal to a control board, and their reaction time is long. Mechanical components are bound to wear out, they are affected by dirt and oil, and they are much more labor intense to mount. Furthermore, their maintenance is very expensive since the pressure in the system must be cut off before maintenance, and new refrigerant must be charged to the system.

**Limitations of mechanical switches:** it is not possible to install intelligence as, for example, in electronic switches. A mechanical switch is digital: either ON or OFF. This limits the mechanical switches from achieving the most optimal position and thus the effectiveness of the entire plant. Furthermore, mechanical switches cannot identify the medium inside in the respective level (phase measurement).



*Mechanical flow switch. Compared to electronic switches, the mechanical flow switch is twice as expensive to install and requires maintenance.*

**Limitations of liquid indicators:** liquid indicators are mainly affected by dirt in the system and to some degree by oil. When liquid indicators are dirty, they do not function properly and may have difficulty to identify the actual level. If the level is higher than the liquid indicator is able to detect, several liquid indicators must be mounted on a vertical column. In situations where the level must be read from a vertical column, it may be difficult to identify the level in the system with large fluctuations in a short period of time. This problem has been solved by measuring the level in a measurement meter, where wave movements are suppressed.

**Limitations of mechanical level regulators:** for instance, in chillers, level regulators are mounted that are in fact float switches, identical to the ones mounted in tanks. This restricts the mounting possibilities since the physical size and design require a certain location in the plant. Mechanical level regulators are also affected by the amount of oil in the system, because the oil may cause the valve to drop as well as cause wear on all moving parts. The valve is also digital, i.e. ON/OFF with no possibility to install intelligence.

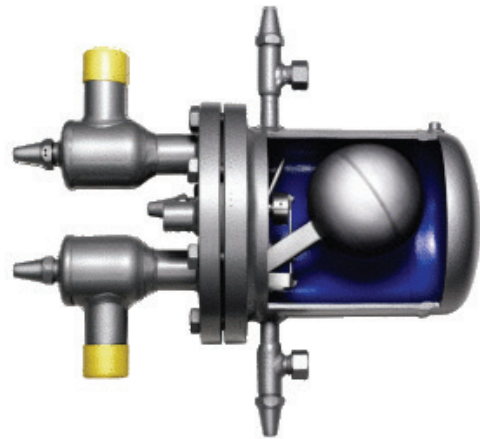

*Mechanical flow controller. Compared to an electronic flow controller, a mechanical flow controller is substantially larger and cannot be placed optimally in a chiller due to its size.*

## Are there any solutions to all mentioned limitations of using electronic sensors?

The answer is YES! Electronic sensors may also be used in other situations where there were no solutions available before. One of the greatest advantages of electronic sensors is that they have split design that allows performing diagnostics and maintenance without cutting off the pressure in the vessel. Are there no disadvantages at all? YES and NO – sensors are usually expensive to install, because it requires both mechanical installation and connection to the control board. If one should consider sensors from the latter point of view, then they are not the right choice. But if one considers sensors together with the life cycle costs of a refrigeration plant, then sensors will minimize the need for operating staff.



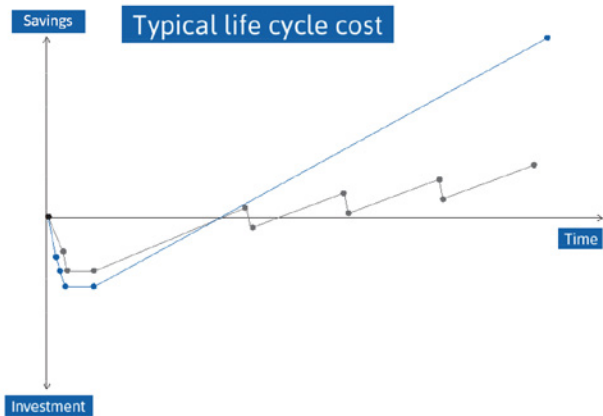

In the table, typical costs for the purchase and installation of mechanical and electronic components are indicated for the first period. The investment depends on the type, but in most cases the installation costs are slightly higher since the electronic components must be connected to the refrigeration system's controller. On the other hand, the revenue on electronic components is somewhat better, since the time needed for servicing and maintenance is eliminated.

### Advantages and possibilities of electronic switches:

An electronic switch can replace either a liquid indicator or a mechanical float switch. The technology often applied in the industry is the capacitive principle, where the sensor measures the dielectric constant, and the measured signal is then processed in a microprocessor with an opportunity of several output signal types. The switch functionality allows installing the following applications:

1. Detect whether there is a specific level in the vessel. In this application, the sensor has been programmed so that it activates only the cooling agent and not oil or dirt.
2. Detect whether there is a specific level in the oil vessel flow

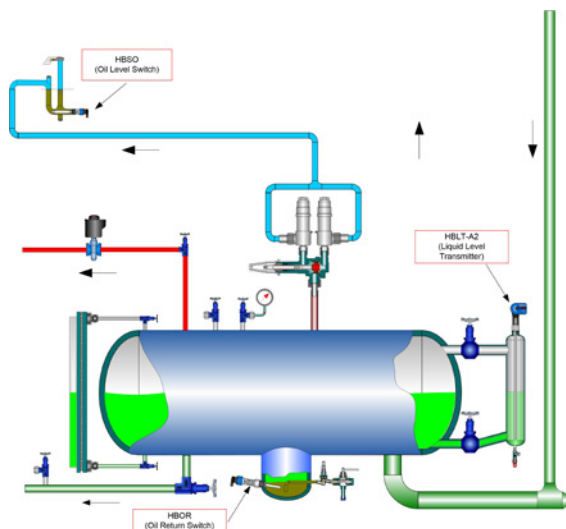

Electronic switches allow for many possibilities since they have built-in intelligence. Here you can see a sensor that sends a signal to the operator when the oil sump needs to be tapped. In conjunction with the safety valve, a sensor is placed at the outlet of the pipework, which sends a signal if the safety valves have been opened.

in a tube or oil in the compressor. In this application, the sensor has been programmed so that it activates only the oil and not the refrigerant. A mechanical solution or other electronic sensors with other measuring principles would not be able to measure this difference and would result in break down of the compressor.

3. Detect whether there is a specific medium at a defined level in the vessel. In this application, the sensor functions as a phase difference indicator, i.e. it can signal whether the oil or refrigerant is present. The measurements are taken at the bottom of the tank where the oil is accumulated (ammonia plant). An operationally reliable identification was not possible before when oil draining was necessary.
4. Detect whether the pressure in the system has been too high, and thus whether the safety valve had been activated. The sensor is mounted at the outlet tube with the water seal function, and the oil is filled in the water seal. In this application, the operational improvement of safety valves is simultaneously performed since they are not disturbed by air or air traps in the tube system.

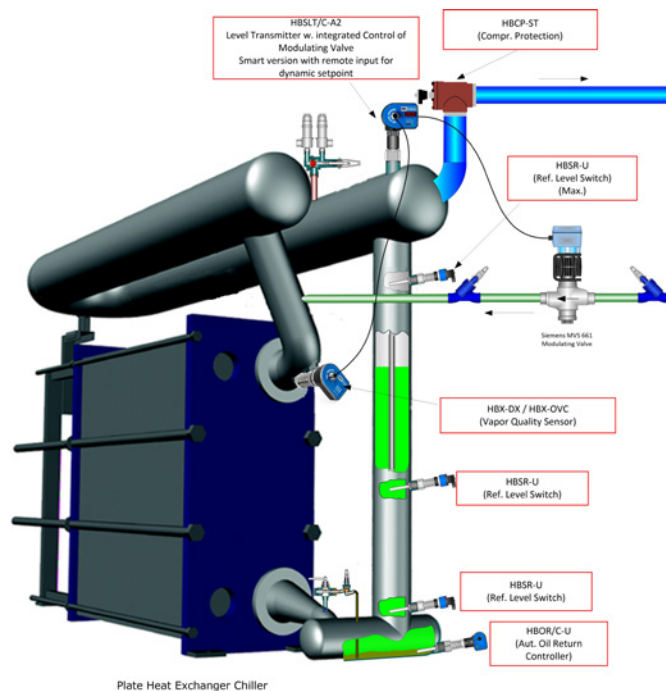

5. The electronic switch can replace liquid indicators in refrigeration tunnels that are used for identification of the U-tube plate heat exchangers from Alfa Laval are fitted with electronic level control, min./max. level, as well as alternative detection of oil in the outlet of the exchanger. This allows for automatic monitoring and control of the level in the plate heat exchanger, as well as safety monitoring.

level of refrigerant. This switch type may be used at -50°C and has a high level of ingress protection (IP) that allows high-pressure washing and high temperatures. All application types may be mounted according to PED Directive category 4. At category 4 installation, signals must

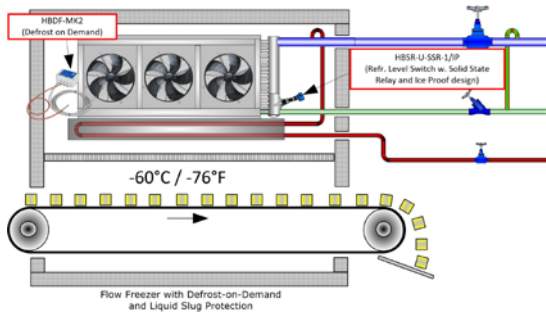

In the freezer tunnel, an ice-proof switch is used which provides an indication of the level of the refrigerant liquid. The alternative to this was sight glass, which was inappropriately placed and hence not always monitored, with the risk that the pipework might burst during defrost.

be doubled and connected according to the EN50156 standard via a safety relay or a safety PLC. There are several possibilities for this on the market, for example, Wieland's safety PLC Samos Pro complies with the requirements of the EN50156 standard.

### Advantages and possibilities of electronic level sensors:

Level measurements in vessels are also performed according to the capacitive principle, where the same advantages are reached as for switches, i.e. the sensor is less affected by oil and dirt. The function is also the same, where the sensor measures the dielectric constant and the level that is turned into charging (capacity). The level of charging is linear with the level in the vessel. Also here, the signal is processed in the microprocessor with an opportunity to adjust it to a specific application. Usually, a 4-20 mA signal is used from the sensor as a linear indication of the level in the vessel. In addition to the function of measuring the level, the microprocessor has a range of other functions:

1. Alarm limit may be set in the area 0-100 %.
2. A filter may be installed that subdues the signal and provides an average measurement in case of wave ripples in the tank. Allows mounting the sensor directly in the vessel during the welding of the measurement meter.
3. In addition to measuring, the sensor can also function as a regulator, i.e. pump or valve control may be performed directly from the sensor. This allows reducing board installation costs.

Advantages and possibilities of electronic level regulators:  
An electronic level regulator is merely a short level bar with the same regulating functions as described in point 3 under level sensor. The set-up functions of the microprocessor in this application have been expanded. Here, it is possible to set:

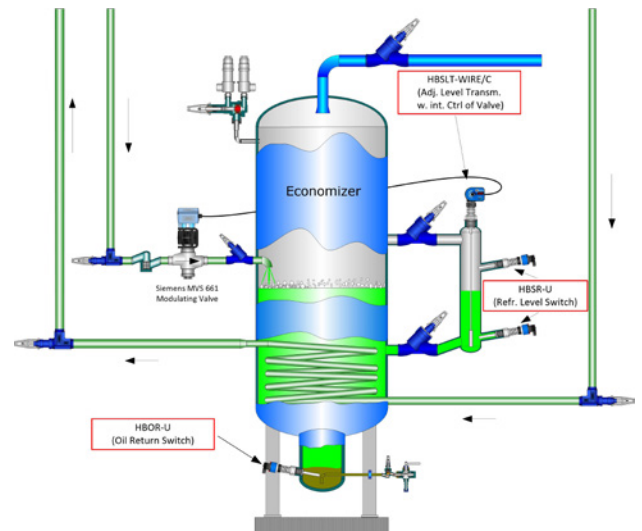

Economizers are fitted with an electronic level control, and min./max. level switches are installed in the vessel. Similarly, a switch is installed for detecting the oil level in the oil sump. This allows for automatic operation of the receiver, as well as the possibility of controlling the liquid level.

1. Regulation functions: low or high pressure switch.
2. Min. or max. level alarm
3. Set point and P-band
4. Output function: NC or NO in addition to programming functions, this solution is considerably more flexible in relation to the mounting, and the regulation may be performed at a more optimal location.

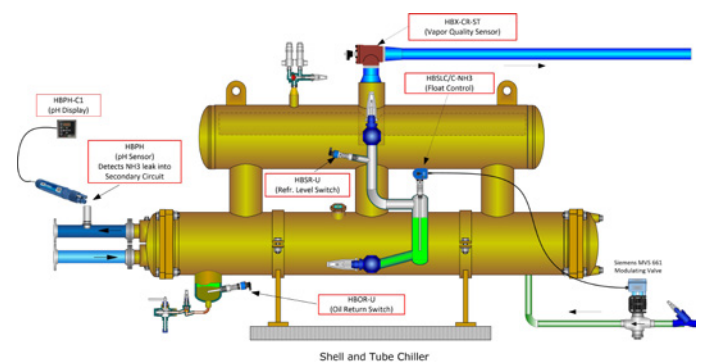

Chillers are fitted with an electronic level control. The minimalistic design of the control system allows for better placement of the control system and the liquid level in the chiller.



# Vapor Quality Sensors



# Energy Efficient Evaporator Control

Most refrigeration plants use either direct expansion with a classic thermal expansion valve or overfeed systems with circulated liquid. Now there is an alternative that eliminates the disadvantages of the two systems and makes it possible to build a simple energy efficient system with a small refrigerant charge.

The solution is to use a vapor quality sensor that measures the liquid content in the gas leaving the evaporator and controls the expansion valve based on the measured vapor quality. This eliminates the need for superheat in DX systems which basically is waste of energy and improve the efficiency of the evaporator.

Overfeed evaporators with circulated refrigerant can use the vapor quality sensor to control the circulation ratio and optimize the capacity of the evaporator.

## The Vapor Quality Sensors Can Be Used For:

### Simple efficient DX systems

- With the Vapor Quality sensor you can eliminate superheat and control your expansion valve directly

### Overfeed systems

- Control your circulation rate and make your system more efficient at any load

### Ammonia carbamate detection

- Leak alarm for CO<sub>2</sub> into ammonia for cascade systems at an early stage before the system get damaged

### Compressor protection

- Detect liquid in the suction line and prevent liquid hammering

## Benefits and Opportunities

The sensor provides an instant signal without delay which is ideal for controlling the evaporation process in a refrigeration plant. The conventional thermo valve reacts significantly slower and a significant superheating of the gas is needed.

The sensor has no moving mechanical parts and no service is needed. The mechanical part is made from carbon or stainless steel and there are a few plastic parts all approved for most common refrigerants including ammonia.

The vapor quality sensors are mounted in straight pipes or in a strainer house. This secures a precise positioning of the sensor element and repeatable results.

### Functionalities:

- Measures the content of liquid in a refrigerant gas  
Instant measurement
- No moving parts
- Suited for most common refrigerants and pipes dimensions from 1/4" to 12" and DN7 to DN300

### Product Features:

- Energy savings for DX systems - ensures semi-flooded operation and eliminates superheat
- Low charge - high efficiency DX plants are possible also for ammonia
- Optimized evaporation control for both DX and over-feed systems
- Direct control of electric expansion valve or liquid valve in overfeed systems - No PLC is needed



## The Vapor Quality Family

The Vapor Quality Sensors are currently developed for most common refrigerants as a straight pipe version and two elbow versions. Basically they have the same functionality but with a different design to match different system designs. All sensors have to be mounted so it is draining refrigerant and no refrigerant is trapped when the system is stopped.

### Measure the Mix Between Liquid and Gas

A vapor quality sensor can measure the mix between gas and liquid in a refrigerant from 0 % gas to 100 % gas, a measurement which no other sensor can provide. It consists of a tube, with simple metal inserts, where the mix of two phases pass through. The sensor measures the dielectric constant of the fluid, and as two different phases (liquid/gas) has different dielectric constant, the mix between the two, can be calculated. The output of the sensor is the "X" value which is the Volume % of liquid in the gas.

Conventional temperature sensor/thermostatic valve

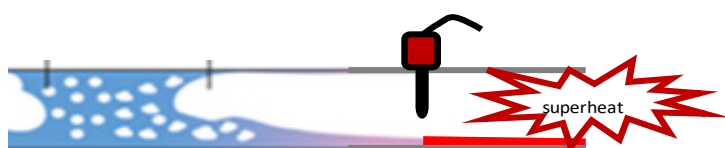

Vapor quality sensor

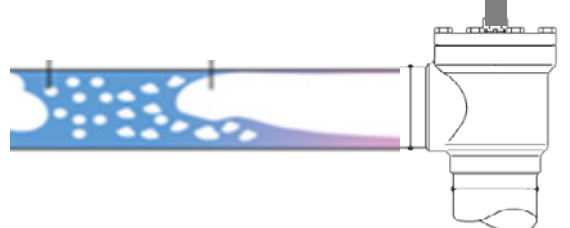

### Optimize the Evaporator

The evaporator efficiency depends on the liquid content of the substance and the flow rate. The figure shows that the efficiency depending on the vapor quality from X=0 wet to X=1 dry gas. The highest efficiency is achieved in the semi flooded operation area from a X value 0.5 to 0.9. In this area the substance is a mix between some liquid and a lot of gas.

As soon as the gas becomes dry beyond 0.9 the efficiency drops dramatically and at the same time the gas is superheated. In a conventionally DX (direct expansion) system the gas is heated up to 5-10 K superheat and that creates a loss in efficiency in the evaporator as 20-30 % of the area is used for superheating. At the same time superheating is a waste of energy and should be avoided.

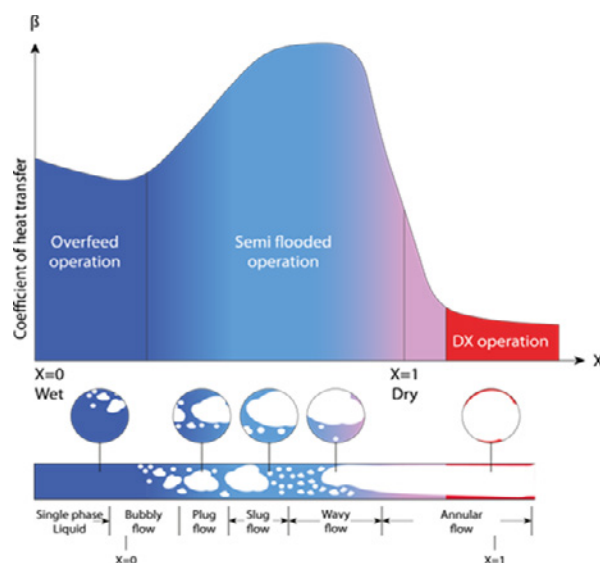

## Special applications

The Vapor Quality Sensor can also be used for:

### Compressor protection

When mounted in the compressor suction line the sensor can detect the liquid like in a DX application and can prevent liquid hammering.

### Leakage detection of ammonia carbamate and vapor quality at the same time

The sensor can be used for detecting CO<sub>2</sub> leaking into an ammonia cascade system creating ammonia carbamate. The sensor can actually also be used as a vapor quality sensor because it is only the alarm function which is used when detecting ammonia carbamate.

# Sensors and Controllers for NH<sub>3</sub>, CO<sub>2</sub> & HFC/HFO Refrigeration Installations

## Sensors and Controllers

**Function:** Vapor Quality Sensor in Strainer Housing  
**Applications:** Gas quality measurement  
**Refrigerant Temperature:** -60°C/+150°C  
**Supply:** 24 V AC/DC  
**Output:** 4...20 mA/PNP-1A



Page 23

**Function:** Vapor Quality Sensor, Inline  
**Applications:** Gas quality measurement  
**Refrigerant Temperature:** -60...+80°C  
**Supply:** 24 V AC/DC  
**Output:** 4...20 mA/PNP-1A



Page 27

**Function:** Vapor Quality Sensor, Angle Rod  
**Applications:** Gas quality measurement  
**Refrigerant Temperature:** -60...+80°C  
**Supply:** 24 V AC/DC  
**Output:** 4...20 mA/PNP-1A



Page 30

# Vapor Quality Sensor in Strainer Housing

## Category: HBX-CR-ST / HBX-DX-ST



### Functional description:

With a vapor quality sensor integrated into a standard strainer house you are ensured safe functionality of the sensor and easy installation. The butt-welded connection makes it easy to weld with same size of piping.

Please be aware that the flow direction of the vapor quality sensor is opposite of the flow direction when used as a strainer. If installed with wrong flow direction functionality will NOT be correct.

Besides the benefit of easy installation this solution makes it easy to dismantle the lid with the sensor conductor and clean it if necessary.

The sensor integrated into standard strainer housing is available in both carbon steel DN20 to DN300 and stainless steel DN20 to DN65. Ask for availability if size outside of this range is requested

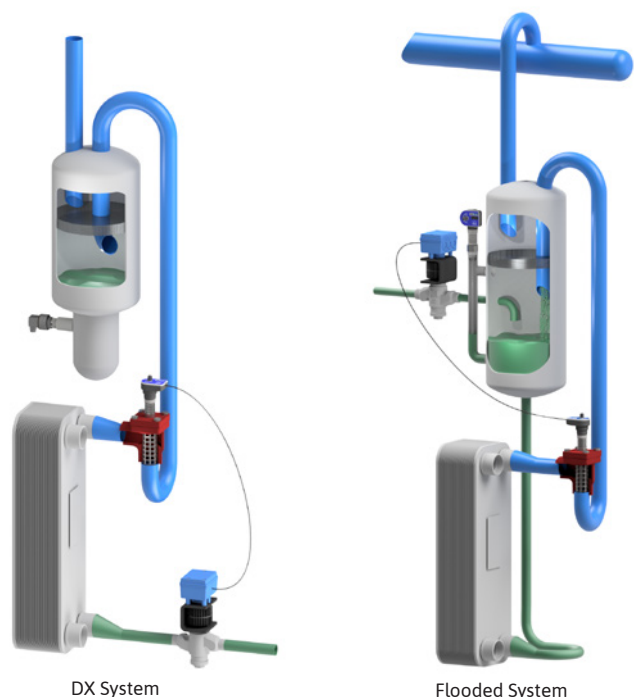

- Available as 2-wire sensor
- Now with ATEX / IECEx certificate (This version is without LED display)

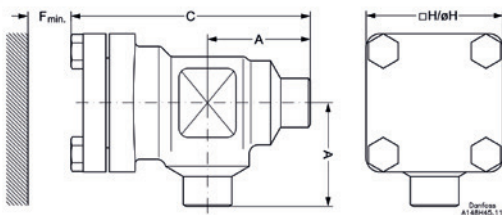

In the sizes DN20-DN40 the strainer is extended with a 100 mm tube.

Strainer size		A	C	H	Fmin	Weight (Excl. Sensor)
DN 20 (¾")	mm	45	105	60	68	1,1 kg
	in	1,77	4,13	2,36	2,68	2,4 lbs
DN 25 - 40 (1"-1 ½")	mm	55	132	70	95	1,7 kg
	in	2,17	5,20	2,76	3,74	3,7 lbs
DN 50 (2")	mm	60	132	77	92	2,8 kg
	in	2,36	5,20	3,03	3,62	6,2 lbs
DN 65	mm	70	152	90	107	3,8 kg
	in	2,76	5,98	3,54	4,21	8,4 lbs

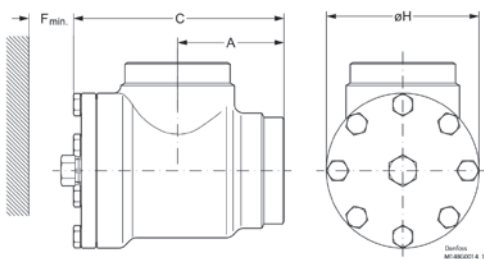

Strainer size		A	C	H	Fmin	Weight (Excl. Sensor)
DN 80 (3")	mm	90	189	129	133	7,3 kg
	in	3,54	7,44	5,08	5,24	16,1 lbs
DN 100 (4")	mm	106	223	156	163	11,9 kg
	in	4,17	8,78	6,14	6,42	26,2 lbs
DN 125 (5")	mm	128	268	192	190	21,2 kg
	in	5,04	10,6	7,56	7,48	46,7 lbs
DN 150 (6")	mm	145	303	219	223	30,5 kg
	in	5,71	11,93	8,62	8,78	67,2 lbs
DN 200 (8")	mm	180	372	276	280	68 kg
	in	7,09	14,65	10,87	11,02	150 lbs

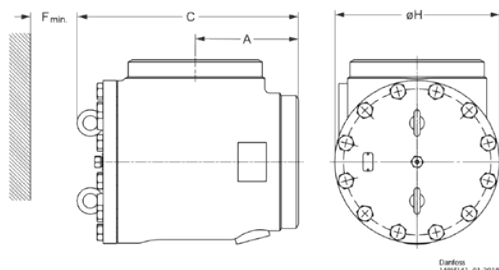

Strainer size		A	C	H	Fmin	Weight (Excl. Sensor)
DN 250 (10")	mm	210	450,5	334	285	89,6 kg
	in	8,27	17,74	13,14	11,22	197,5 lbs
DN 300 (12")	mm	240	510,5	384	340	122 kg
	in	9,45	20,1	15,12	13,39	269 lbs



## Technical data

Power supply		Mechanical specifications	
Voltage	24 V AC/DC	Welding connection	Butt weld
Current consumption - sensor only*	Max 250 mA	Material liquid parts	AISI 304 / PEEK Carbon steel
Electrical connection	M12 - 5 pins	Material - electronic parts	GF BLK, Nylon 6 (PA)
Output		Size	See drawing and table on previous page
Analog signal	4-20 mA	Weight	See table on previous page
Control	Build in controller for valve (optional)	Type	Front house
Environmental conditions		Approvals	
Refrigerants	Applicable to HC, HFC/HFO, NH <sub>3</sub> , CO <sub>2</sub>	EMC test	EN 61000-2
Temperature range	-60°C/+150°C (-76°F/+302°F)	Cable	
Max. working pressure	52 barg (754 psig)	5 mtr cable with M12 connector	HBXC-M12/5
Degree of protection	IP65	Cable specification	PUR -5 x 0,34mm <sup>2</sup>
Vibrations	IEC 68-2-6 (4g)	Indication	
Configurations		LED indication	LED (green, yellow and red)
Configuration	With HB Tool		

\* Total consumption is sensor consumption plus output and it depends on ambient temperature.

## Technical data - valve regulation

Valve control (Modulating valve)		Valve control (Stepper motor)	
Signal to valve	4-20 mA	Stepper motor steps	25-5000 steps
Valve regulation	PI-regulation	Stepper motor speed	2-40 m/s
Valve control (PWM)		Stepper motor phase current	0-750 mA
Signal to valve	24V AC/DC	Stepper motor holding current	0-250 mA
PWM period	0-120 s (default 6 s.)	Cable specification (valve control)	
		Length	3 m (118")
		Cable size	3 x 0.75 mm <sup>2</sup>
		Cable glands	PG7 / M8

## How to order

HBX Vapor Quality Sensors come in numerous variants - all customized to the application. To make the right configuration of the sensor please go to [www.hbproducts.dk](http://www.hbproducts.dk) and fill out the "Product Specification Form" placed under the download tap at the bottom of the Vapor Quality Sensor product pages.

The HBX Vapor Quality Sensor in Strainer Housing is available in the following dimensions and steel types::

Pipe diameter	Stainless steel	Carbon steel
DN20 (3/4")	Available	Available
DN25 (1")	Available	Available
DN32 (1 1/4")	Available	Available
DN40 (1 1/2")	Available	Available
DN50 (2")	Available	Available
DN65 (2 1/2")	Available	Available
DN80 (3")	On request	Available
DN100 (4")	On request	Available
DN125 (5")	On request	Available
DN150 (6")	On request	Available
DN200 (8")	Not available	Available
DN250 (10")	Not available	Available
DN300 (12")	Not available	Available

# Vapor Quality Sensor, Inline

Category: HBX-CR-IN / HBX-DX-IN



## Functional description:

The straight version of the vapor Quality Sensor is called Inline. This sensor type is available from 1" to 2" and the sensor accepts flow in both directions. The pressure loss in the sensor is very low due to the straight flow and smooth internal design.

Mounting can be both horizontal and vertical position. The sensor is made in stainless steel and can be butt welded (TIG) or brazed into the system.

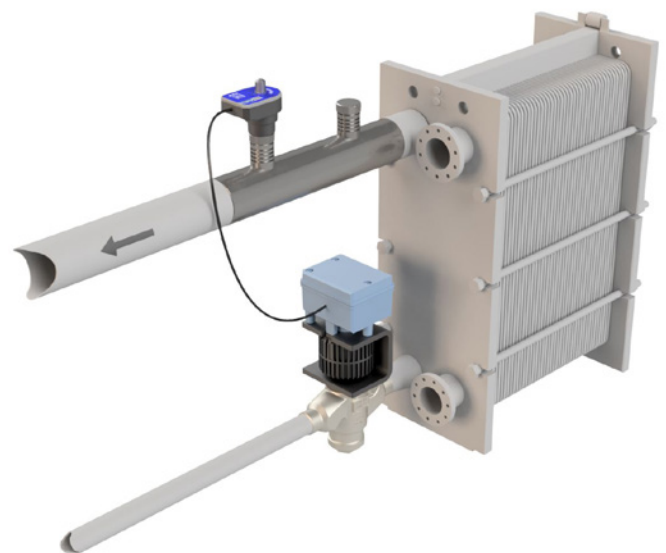

- Available as 2-wire sensor
- Now with ATEX / IECEx certificate (This version is without LED display)

### Technical data - sensor

Power supply		Mechanical specifications	
Voltage	24 V AC/DC + 10%	Material – mechanical parts	AISI 304 / PTFE
Current consumption - sensor only*	Max 250 mA	Material – electronic parts	Nylon 6 (PA)
Electronic connection	M12,5 pins	Dimensions	See drawing
Output		Environmental conditions	
Analog output	4-20 mA	Ambient temperature	-30...+50°C
Alarm output	Max 1 A (24W)	Refrigerant temperature	-60...+80°C
LED indication	Green, yellow, and red	Max pressure	100 bar
Max. possible resistance	500 ohm	Protection degree	IP65
Cable specification (power supply)		Vibrations	IEC 68-2-6 (4g)
Cable size	5 m - 5 x 0.34 mm <sup>2</sup>	Accessories (To be ordered separately)	
Cable glands	PG7 / M8	Splitter box	HBxC-splitbox
Cable resistance	500 Ω/Km	Configuration	
Approvals		Type of configuration	HB Tool
EMC test	EN 61000-2	Tool to be used	HBX software

\* Total consumption is sensor consumption plus output and it depends on ambient temperature.

### Technical data - valve regulation

Valve control (Modulating valve)		Valve control (Stepper motor)	
Signal to valve	4-20 mA	Stepper motor steps	25-5000 steps
Valve regulation	PI-regulation	Stepper motor speed	2-40 m/s
Valve control (PWM)		Stepper motor phase current	0-750 mA
Signal to valve	24V AC/DC	Stepper motor holding current	0-250 mA
PWM period	0-120 s (default 6 s.)	Cable specification (valve control)	
		Length	3 m (118")
		Cable size	3 x 0.75 mm <sup>2</sup>
		Cable glands	PG7 / M8

## Mechanical dimensions

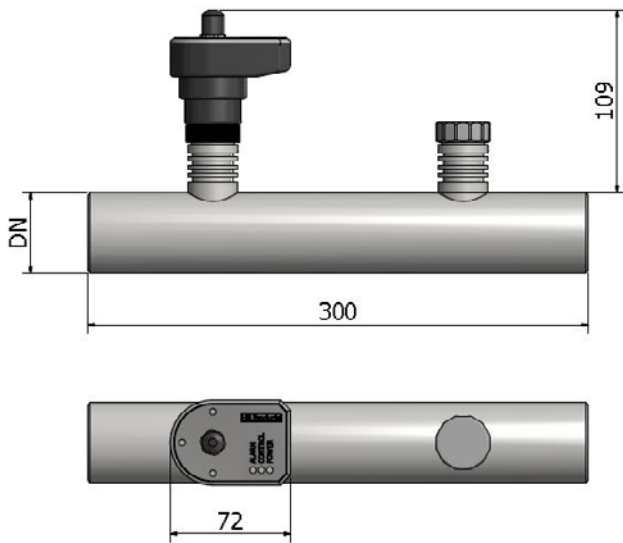

## How to order

HBX Vapor Quality Sensors come in numerous variants - all customized to the application. To make the right configuration of the sensor please go to [www.hbproducts.dk](http://www.hbproducts.dk) and fill out the "Product Specification Form" placed under the download tab at the bottom of the Vapor Quality Sensor product pages.

The HBX Vapor Quality Sensor, Inline is available in the following dimensions and steel type:

Pipe diameter	Stainless steel
DN25 (1")	Available
DN40 (1½")	Available
DN50 (2")	Available

# Vapor Quality Sensor, Angle Rod

Category: HBX-DX/C-SS-XX | HBX-DX/S-SS-XX | HBX-DX/PWM-SS-XX

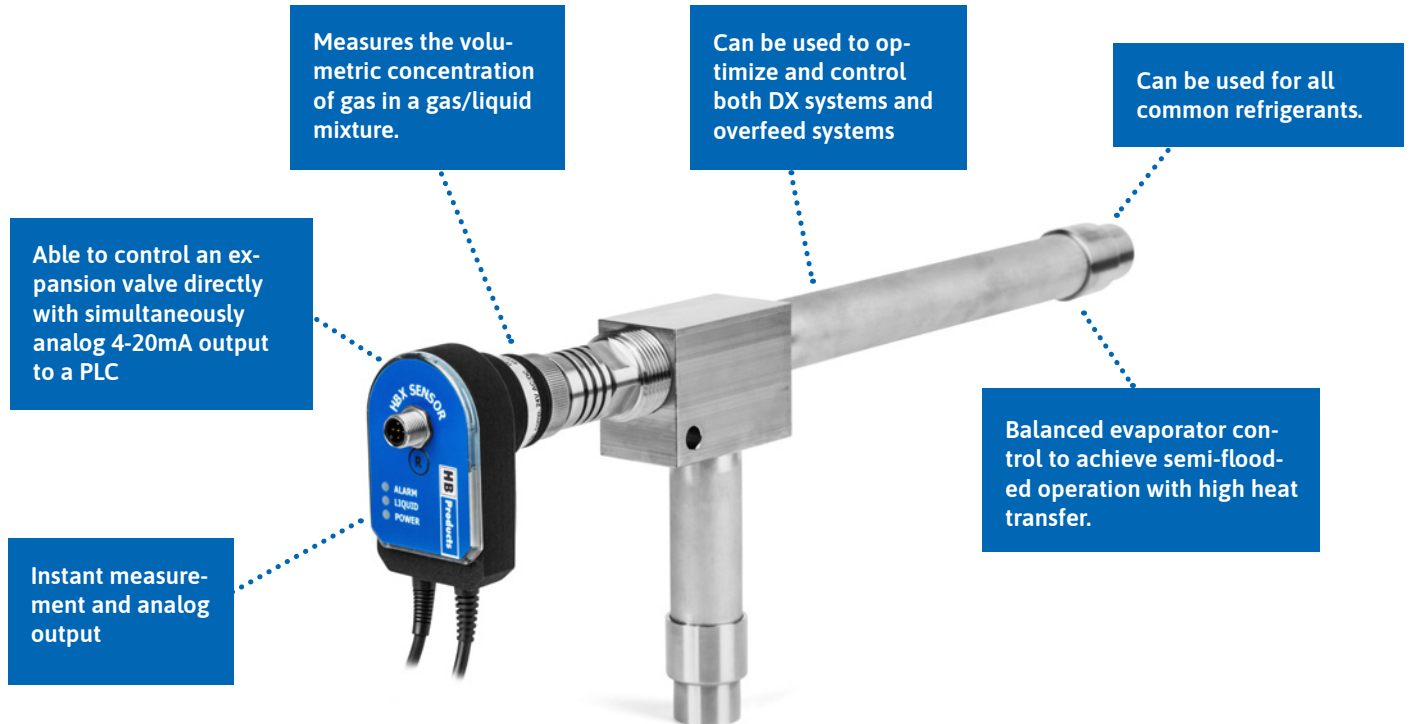

Measures the volumetric concentration of gas in a gas/liquid mixture.

Can be used to optimize and control both DX systems and overfeed systems

Can be used for all common refrigerants.

Able to control an expansion valve directly with simultaneously analog 4-20mA output to a PLC

Balanced evaporator control to achieve semi-flooded operation with high heat transfer.

Instant measurement and analog output

## Functional description:

The Angle Rod version is suited for smaller systems and is made in stainless steel. It accepts flow in both directions and is suited for all common refrigerants. For HFC/HFO's you need to pick an over sized sensor to keep down pressure loss. The sensor comes with reductions to compensate for a restricted flow area as standard.

The sensor is made in stainless steel and can be butt welded (TIG) or brazed into the system. The sensor element can be removed and cleaned if necessary. The sensor is available from 1/4" to 1" pipe size.

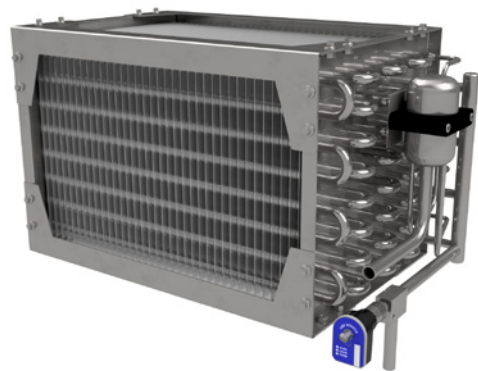

- Available as 2-wire sensor
- Now with ATEX / IECEx certificate (This version is without LED display)

### Technical data

Power supply		Mechanical specifications	
Voltage	24V AC/DC	Size	Please see drawing
Current consumption - sensor only*	250mA with heater	Material	Aisi304, PA6
Electronic connection	DIN Plug or M12, 3p	House type	Front
Output		Environmental conditions	
Output signal "X" 0.8 to 1.0	4-20mA / 0-10V	Ambient temperature	-40...+50°C
Valve output, S or C or PWM	Stepper motor, mA, PWM	Refrigerant temperature	-55...+50°C
EMC	EN 61000-2	Max pressure	Max 120 bar
		Vibrations	IEC 68-2-6 (4G)

\* Total consumption is sensor consumption plus output and it depends on ambient temperature.

### Technical data - valve regulation

Valve control (Modulating valve)		Valve control (Stepper motor)	
Signal to valve	4-20 mA	Stepper motor steps	25-5000 steps
Valve regulation	PI-regulation	Stepper motor speed	2-40 m/s
Valve control (PWM)		Stepper motor phase current	0-750 mA
Signal to valve	24V AC/DC	Stepper motor holding current	0-250 mA
PWM period	0-120 s (default 6 s.)	Cable specification (valve control)	
		Length	3 m (118")
		Cable size	3 x 0.75 mm <sup>2</sup>
		Cable glands	PG7 / M8

### Mechanical dimensions

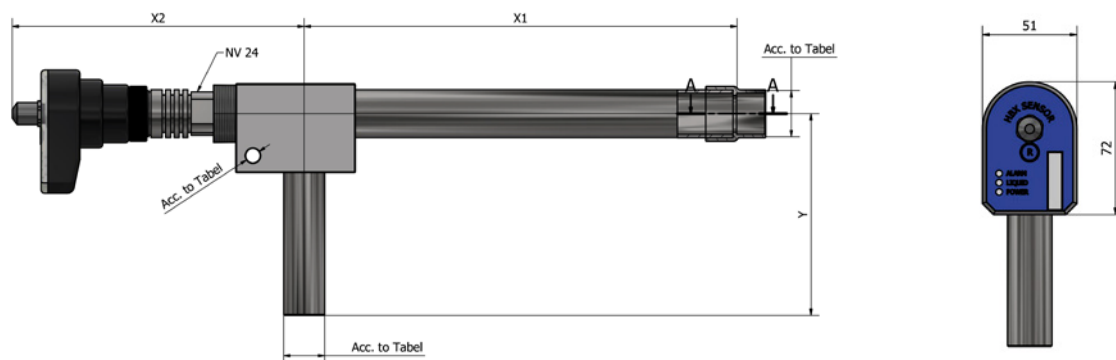

For installation in copper pipes in inches				
Type	Pipe	X1	X2	Y
HBX-DX-SS-3/8	3/8"	246	130	112
HBX-DX-SS-1/2	1/2"	246	130	112
HBX-DX-SS-5/8	5/8"	248	135	114
HBX-DX-SS-3/4	3/4"	248	135	115
HBX-DX-SS-7/8	7/8"*	250	140	115

\*Only for CO<sub>2</sub>

For installation in stainless steel pipes in mm				
Type	Pipe	X1	X2	Y
HBX-DX-SS-3/8	ø10 mm	246	130	112
HBX-DX-SS-1/2	ø13mm	246	130	112
HBX-DX-SS-5/8	ø16mm	248	135	114
HBX-DX-SS-3/4	ø20mm	248	135	115
HBX-DX-SS-7/8	ø24mm"*	250	140	115

\*Only for CO<sub>2</sub>

## How to order

HBX Vapor Quality Sensors come in numerous variants - all customized to the application. To make the right configuration of the sensor please go to [www.hbproducts.dk](http://www.hbproducts.dk) and fill out the "Product Specification Form" placed under the download tap at the bottom of the Vapor Quality Sensor product pages.

The HBX Vapor Quality Sensor, Angle Rod is available in the following dimensions and steel type::

Pipe diameter	CO <sub>2</sub> and other refrigerants	HFC/HC/HFO
1/4"	Available	Available
3/8"	Available	Available
1/2"	Available	Available
5/8"	Available	Available
3/4"	Available	Available
7/8"	Available	Not available





# NH<sub>3</sub> - Ammonia

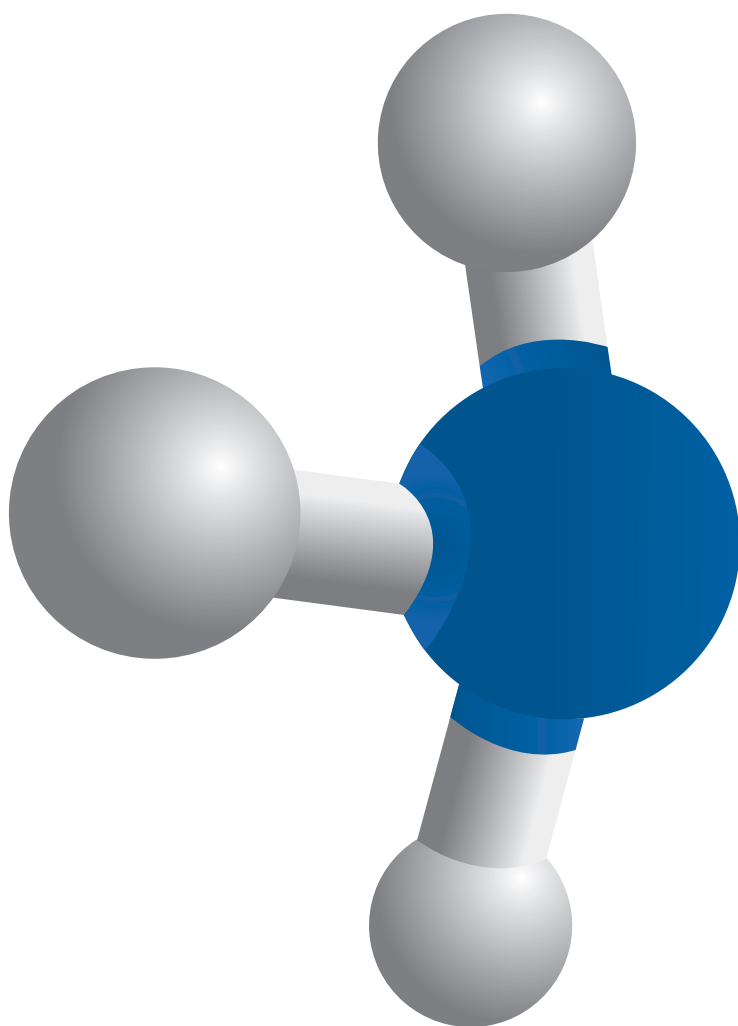

# Why Use Ammonia (NH<sub>3</sub>) in Industrial Refrigeration?

In 1876, Carl Von Linde used ammonia for refrigeration for the first time in a steam compression machine. Other refrigerants, like CO<sub>2</sub> and SO<sub>2</sub>, were also commonly used until the 1920s. The development of CFC in the US tipped the scales in favor of these refrigerants, because CFC refrigerants were seen as harmless and particularly stable chemicals when compared to all other refrigerants used at the time. The environmental consequence of the release of refrigerants on a massive scale could not be anticipated back then. CFC refrigerants were marketed as safe refrigerants, which resulted in a growing demand and success for CFC.

Ammonia came under a great deal of pressure due to the success of CFC, but it retained its position especially in large industrial systems and within food preservation.

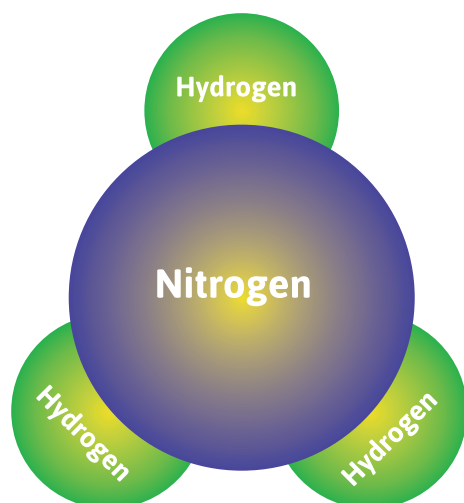

*Ammonia is the most environmentally friendly refrigerant*

In the 1980s, the harmful effects of the CFC refrigerants became apparent, and the general perception was that CFC refrigerants contributed to the destruction of the ozone layer and towards global warming. This led to the Montreal protocol (1989) where almost all countries agreed to phase out CFC over a defined time frame.

In light of the severity of the damage that CFC/HCFC emissions cause to the atmosphere and the effect on global warming, the execution of the plan was hastened in connection with the revision of the Montreal protocol 1990, 1992 Copenhagen, and 1998 Kyoto, Japan. HCFC refrigerants must also be phased out, and Europe is leading the way in this process.

Many countries in Europe have stopped using HCFC refrigerants, and new refrigerants as well. Well-tested and reliable refrigerants like ammonia and CO<sub>2</sub> are being considered for various new applications.

## A number of advantages

Ammonia has a number of advantages, which have been demonstrated through the use of ammonia refrigeration systems over many decades.

## Energy efficiency

Ammonia is one of the most efficient refrigerants, with an application area ranging from high to low temperatures. With the ever increasing focus on energy use, the ammonia refrigeration system is a safe and sustainable choice for the future. A flooded ammonia system will typically be 15-20% more efficient than a corresponding DX R404A. New developments of NH<sub>3</sub> and CO<sub>2</sub> combinations have further contributed to increasing efficiency. Cascade systems with NH<sub>3</sub>/CO<sub>2</sub> are extremely efficient for low and very low temperatures (below -40° C), while NH<sub>3</sub>/CO<sub>2</sub> brine systems are about 20% more efficient than traditional brine solutions.

## The environment

Ammonia is the most environmentally friendly refrigerant. It belongs in the group of so-called "natural" refrigerants and has both a GWP (Global Warming Potential) and an ODP (Ozone Depletion Potential) of zero.

## Safety

Ammonia is a toxic refrigerant and it is also flammable in certain concentrations. Therefore, it must be handled with care, and all ammonia refrigeration systems must be developed in accordance with safety standards. In contrast to other refrigerants, ammonia has a characteristic smell that can be detected even in very low concentrations. This acts as a warning even in case of small ammonia leaks. A combination of ammonia and CO<sub>2</sub> (as cascade or brine) could be a good and efficient solution if it is necessary to reduce the ammonia level.



*When installing ammonia refrigeration systems, an ammonia leak detector must be installed to ensure the safety of the personnel.*

## Smaller pipe sizes

Ammonia requires a smaller pipe diameter than most chemical refrigerants, for both the vapor and liquid phase.

## Better heat transfer

Ammonia has better heat transfer properties than most chemical refrigerants, which enables the use of equipment with a smaller cooling surface. This way, the costs associated with establishing new systems are lower. Since these characteristics also benefit the thermodynamic efficiency of the system, the operational costs will also be lower.

## Refrigerant price

In many countries, the expenses associated with ammonia (per kg) are substantially lower than the price of HFC, CFC or HCFC. This advantage is even greater due to the fact that ammonia has a lower density in liquid form. Furthermore, any refrigerant leakage would be limited when using ammonia, since it would quickly be discovered due to the air smell.

Ammonia is not a universal refrigerant and it is particularly suitable for industrial and heavy commercial applications. Ammonia's toxicity, flammability, and compatibility with materials must always be considered in the assessment. Furthermore, it should be mentioned that a large number of ammonia refrigeration systems exist globally, where these challenges are being successfully managed.

# Ammonia Plant - Principle

**HB Products** WE INCREASE UPTIME, SAFETY AND EFFICIENCY

AMMONIA PLANT -

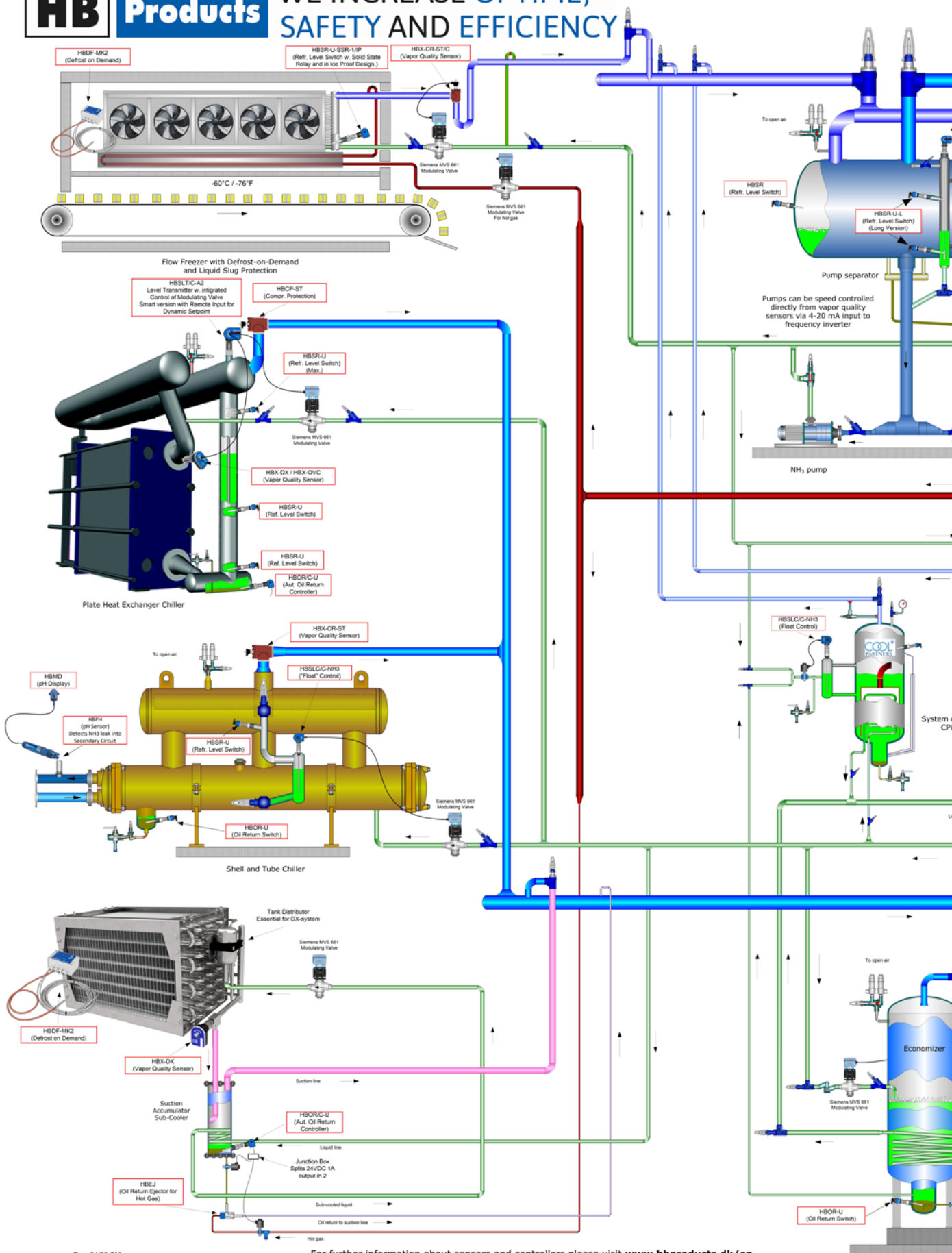



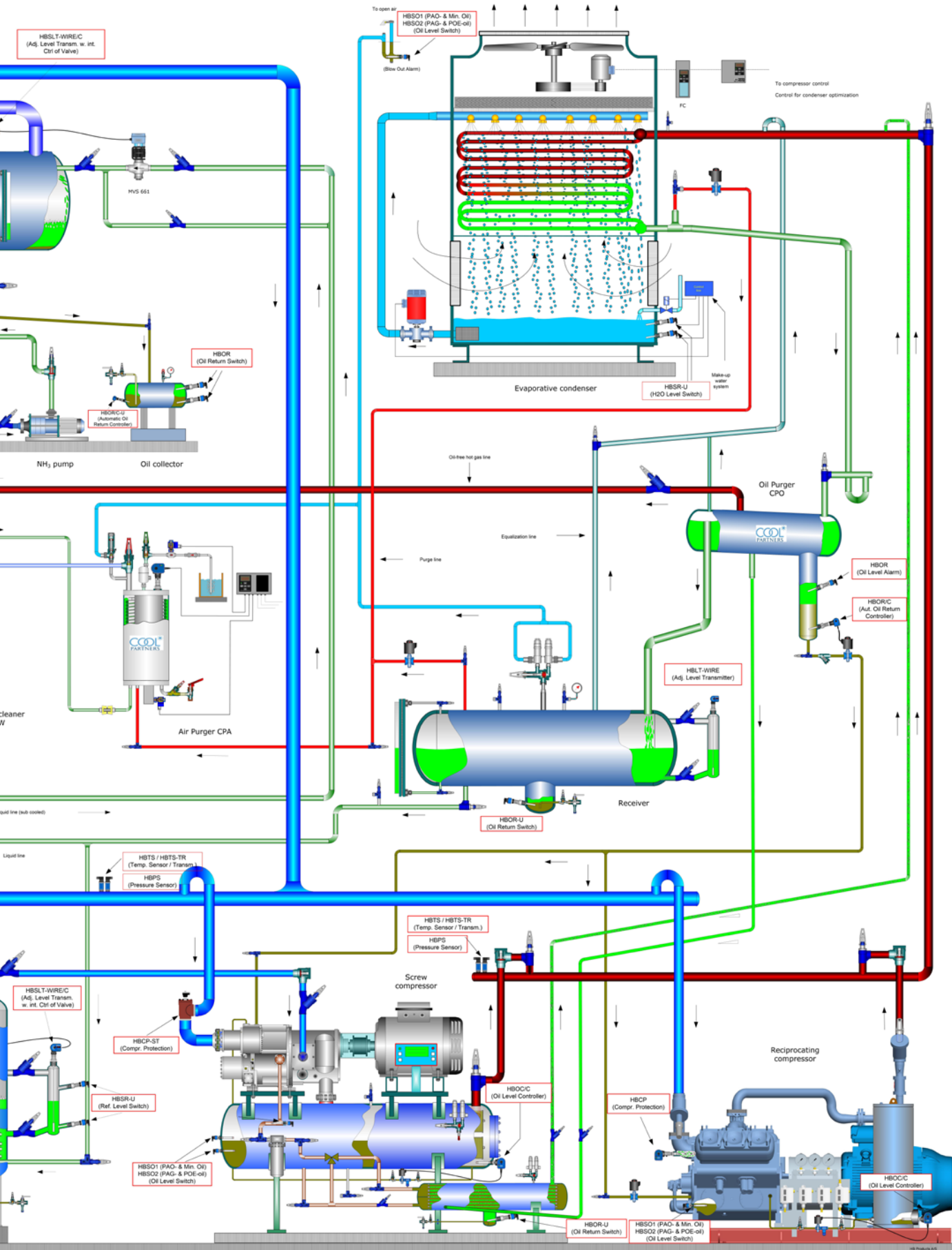

PRINCIPLE











# Switches, Sensors and Controllers for NH<sub>3</sub> Industrial Refrigeration Installations

## ON/OFF Switches

NH <sub>3</sub> liquid	<p><b>Function:</b> NH<sub>3</sub> Liquid Level Switch - 24 V AC/DC  <b>Application:</b> Level switch in vessels  <b>Refrigerant Temperature:</b> -60...+80°C  <b>Supply:</b> 24 V AC/DC  <b>Output:</b> PNP/NPN - 1A</p>		Page 40
	<p><b>Function:</b> NH<sub>3</sub> Liquid Level Switch - 90...240 V AC  <b>Application:</b> Level switch in vessels  <b>Refrigerant Temperature:</b> -60...+80°C  <b>Supply:</b> 90...240 V AC  <b>Output:</b> Solid state relay</p>		Page 43
	<p><b>Function:</b> NH<sub>3</sub> Liquid Level Switch - Low Temperature  <b>Application:</b> Level switch in flow freezers  <b>Refrigerant Temperature:</b> -60...+80°C  <b>Supply:</b> 24 V DC  <b>Output:</b> Solid state relay - 1A</p>		Page 45
	<p><b>Function:</b> NH<sub>3</sub>/CO<sub>2</sub> Leakage Switch  <b>Application:</b> Leakage switch in heat exchangers  <b>Refrigerant Temperature:</b> -60...+80°C  <b>Supply:</b> 24 V DC  <b>Output:</b> PNP - 1 A</p>		Page 47
NH <sub>3</sub> GAS	<p><b>Function:</b> Compressor Protection  <b>Application:</b> Compressor protection sensor  <b>Refrigerant Temperature:</b> -60...+40°C  <b>Supply:</b> 24 V AC/DC  <b>Output:</b> PNP - 1A</p>		Page 50

## Sensors & Controllers

NH <sub>3</sub> liquid	<p><b>Function:</b> NH<sub>3</sub> Liquid Level Sensor – Wire  <b>Applications:</b> Level measurement in standpipes  <b>Refrigerant Temperature:</b> -60...+80°C  <b>Supply:</b> 24 V AC/DC  <b>Output:</b> 4...20 mA/PNP-1A</p>		Page 53
	<p><b>Function:</b> NH<sub>3</sub> Liquid Level Transmitter  <b>Applications:</b> Level measurement in standpipes  <b>Refrigerant Temperature:</b> -60...+80°C  <b>Supply:</b> 24 V AC/DC  <b>Output:</b> 4...20 mA</p>		Page 58
	<p><b>Function:</b> NH<sub>3</sub> Liquid Level Sensor  <b>Applications:</b> Level measurement in standpipes  <b>Refrigerant Temperature:</b> -60...+80°C  <b>Supply:</b> 24 V AC/DC  <b>Output:</b> 4...20 mA</p>		Page 62
	<p><b>Function:</b> NH<sub>3</sub> Liquid Level Controller  <b>Applications:</b> Float regulation in e.g. chillers  <b>Refrigerant Temperature:</b> -60...+80°C  <b>Supply:</b> 24 V AC/DC  <b>Output:</b> 4...20 mA/PNP-1A</p>		Page 66

Sensors & Controllers				
NH <sub>3</sub> liquid	<p><b>Function:</b> Level Controller  <b>Applications:</b> Level control on e.g. pump separators  <b>Supply:</b> 24 V AC/DC / 90-240 V AC  <b>Output:</b> 4...20 mA/3x solid state relays-3/5A</p>			Page 69
	<p><b>Function:</b> pH Sensor  <b>Applications:</b> pH measurement in brine  <b>Liquid Temperature:</b> -15...+95°C  <b>Supply:</b> 20...28 V DC  <b>Output:</b> 4...20 mA</p>			Page 71
	<p><b>Function:</b> pH Display  <b>Applications:</b> Display for pH Level  <b>Supply:</b> 24 V AC/DC / 90-240 V AC  <b>Output:</b> 1x solid state relays-3/5A</p>			Page 73
NH <sub>3</sub> Gas	<p><b>Function:</b> NH<sub>3</sub> Gas Leakage Alarm/Sensor  <b>Applications:</b> Safety switch/sensor for gas leakage detection  <b>Supply:</b> 24 V DC  <b>Output:</b> 4...20 mA / 3 x SPDT, 0,5A</p>			Page 75

# NH<sub>3</sub> Liquid Level Switch - 24 V AC/DC

Category: HBSR-U & HBSR-U-L

Designed for the industrial refrigeration industry - max pressure 100 Bar.

Proven sensor technology for simple transistor output PNP/NPN and NO/NC output function.

Split design which allows for easy installation and diagnostics. The electronic part can be easily disconnected.

Clear indication with LED when refrigerant is detected.

24 V AC/DC voltage supply



- Available as 2-wire sensor
- Now with ATEX / IECEx certificate (This version is without LED display)

## Functional description

HBSR-U is a level switch for the detection of NH<sub>3</sub> and Brine refrigerants.

Typically it is installed in/on the refrigerant vessels, pump separators, economizers or heat exchanger.

The sensor is specially built to resist high pressure and low temperatures.

- For almost 20 years switches from HB Products has been supplied worldwide.
- More than 10.000 switches are produced every year.
- We deliver switches as OEM products to the leading suppliers of industrial refrigeration equipment.

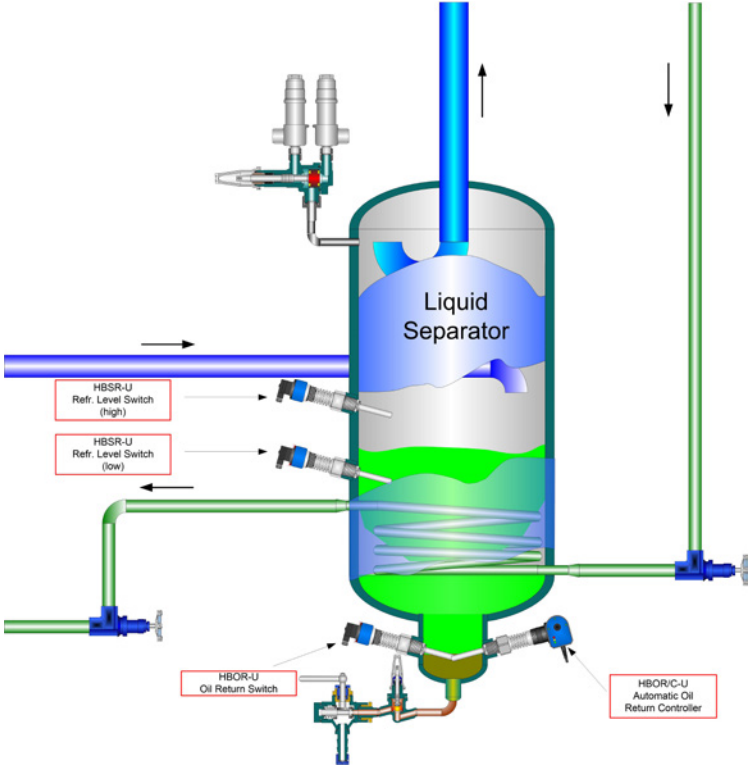



## Technical data

Power supply		Mechanical specifications	
Voltage	24 V AC/DC + 10%	Thread connection	NPT / BSPP / BSPT
Max. current output	Max 50 mA	Material – mechanical parts	AISI 304 / PTFE
Current consumption - sensor only*	200 mA	Material – electronic parts	Nylon 6 (PA)
Plug connection	ISO 4400/DIN 43650	Dimensions for HBSR-U	209x51x45
<b>Output</b>		Dimensions for HBSR-U-L	259x101x45
Output type	PNP or NPN - 50 mA	<b>Environmental conditions</b>	
Output function	NC or NO	Ambient temperature	-30...+50°C
LED indication	4 x LED (red)	Refrigerant temperature*	-60...+80°C
<b>Cable specification*</b>		Max pressure	100 bar
Cable size	3 x 0.34 mm <sup>2</sup>	Protection degree	IP65
Cable glands	PG7 / M8	Vibrations	IEC 68-2-6 (4g)
Cable resistance	500 Ω/Km		
<b>Approvals</b>			
CE	EN 61000-2		

\* Total consumption is sensor consumption plus output and it depends on ambient temperature.

### Mechanical dimensions for HBSR-U

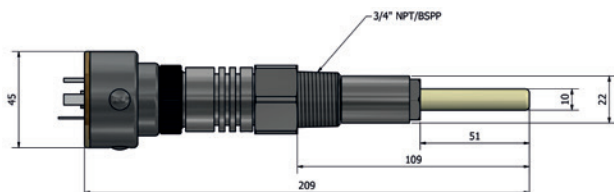

Thread to be sealed with conductive liquid sealing to ensure ground connection.

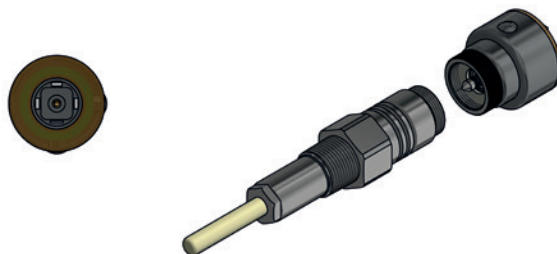

### Mechanical dimensions for HBSR-U-L

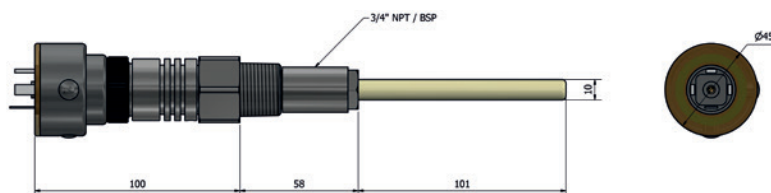

Thread to be sealed with conductive liquid sealing to ensure ground connection.

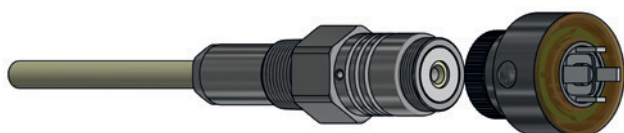

4 x red LED's indicate liquid detection.  
4 x green LED's flashing indicate no detection, but sensor is active.  
4 x red flashing LED's indicate no connection to mechanical unit.

**Switch contact output:**

**NC:** Relay contact is normally closed (current can flow) and opens when liquid is detected.

**NO:** Relay contact is normally open (no current flow) and closes when liquid is detected.

**Ordering codes for HBSR-U-L**

Output	Thread type (G)	Length	Ordering code
PNP / NO	3/4" NPT	160 mm	HBSR-U-L-PNP/NO-2
PNP / NC	3/4" NPT	160 mm	HBSR-U-L-PNP/NC-2
PNP / NO	3/4" BSPT	160 mm	HBSR-U-L-PNP/NO-4
PNP / NC	3/4" BSPT	160 mm	HBSR-U-L-PNP/NC-4
PNP / NO	3/4" BSPP	160 mm	HBSR-U-L-PNP/NO-6
PNP / NC	3/4" BSPP	160 mm	HBSR-U-L-PNP/NC-6
NPN / NO	3/4" NPT	160 mm	HBSR-U-L-NPN/NO-2
NPN / NC	3/4" NPT	160 mm	HBSR-U-L-NPN/NC-2
NPN / NO	3/4" BSPT	160 mm	HBSR-U-L-NPN/NO-4
NPN / NC	3/4" BSPT	160 mm	HBSR-U-L-NPN/NC-4
NPN / NO	3/4" BSPP	160 mm	HBSR-U-L-NPN/NO-6
NPN / NC	3/4" BSPP	160 mm	HBSR-U-L-NPN/NC-6

**Ordering codes for HBSR-U**

Output	Thread type (G)	Ordering code
PNP / NO	1/2" NPT	HBSR-U-PNP/NO-1
PNP / NC	1/2" NPT	HBSR-U-PNP/NC-1
PNP / NO	3/4" NPT	HBSR-U-PNP/NO-2
PNP / NC	3/4" NPT	HBSR-U-PNP/NC-2
PNP / NO	3/4" BSPT	HBSR-U-PNP/NO-4
PNP / NC	3/4" BSPT	HBSR-U-PNP/NC-4
PNP / NO	1/2" BSPP	HBSR-U-PNP/NO-5
PNP / NC	1/2" BSPP	HBSR-U-PNP/NC-5
PNP / NO	3/4" BSPP	HBSR-U-PNP/NO-6
PNP / NC	3/4" BSPP	HBSR-U-PNP/NC-6
NPN / NO	1/2" NPT	HBSR-U-NPN/NO-1
NPN / NC	1/2" NPT	HBSR-U-NPN/NC-1
NPN / NO	3/4" NPT	HBSR-U-NPN/NO-2
NPN / NC	3/4" NPT	HBSR-U-NPN/NC-2
NPN / NO	3/4" BSPT	HBSR-U-NPN/NO-4
NPN / NC	3/4" BSPT	HBSR-U-NPN/NC-4
NPN / NO	1/2" BSPP	HBSR-U-NPN/NO-5
NPN / NC	1/2" BSPP	HBSR-U-NPN/NC-5
NPN / NO	3/4" BSPP	HBSR-U-NPN/NO-6
NPN / NC	3/4" BSPP	HBSR-U-NPN/NC-6

**Spare parts for HBSR-U, HBSR-U-L & HBSR**

Position	Specification	Type	Ordering code
HBSR-U	Electronic parts	PNP/NO	HBSR-U-EL/PNP/NO
		PNP/NC	HBSR-U-EL/PNP/NC
		NPN/NO	HBSR-U-EL/NPN/NO
		NPN/NC	HBSR-U-EL/NPN/NC
HBSR-U	Mechanical parts	1/2" NPT	HBSR-U-MEK-1
		3/4" NPT	HBSR-U-MEK-2
		3/4" BSPT	HBSR-U-MEK-4
		1/2" BSPP	HBSR-U-MEK-5
		3/4" BSPP	HBSR-U-MEK-6
HBSR-U-L	Electronic parts	PNP/NO	HBSR-U-L-EL/PNP/NO
		PNP/NC	HBSR-U-L-EL/PNP/NC
		NPN/NO	HBSR-U-L-EL/NPN/NO
		NPN/NC	HBSR-U-L-EL/NPN/NC
HBSR-U-L	Mechanical parts	3/4" NPT	HBSR-U-L-MEK-2
		3/4" BSPT	HBSR-U-L-MEK-4
		3/4" BSPP	HBSR-U-L-MEK-6
HBSR	Electronic parts	PNP/NO	HBSR-EL/PNP/NO
		PNP/NC	HBSR-EL/PNP/NC
		NPN/NO	HBSR-EL/NPN/NO
		NPN/NC	HBSR-EL/NPN/NC

# NH<sub>3</sub> Liquid Level Switch - 90...240 V AC

Category: HBSR-U-SSR2

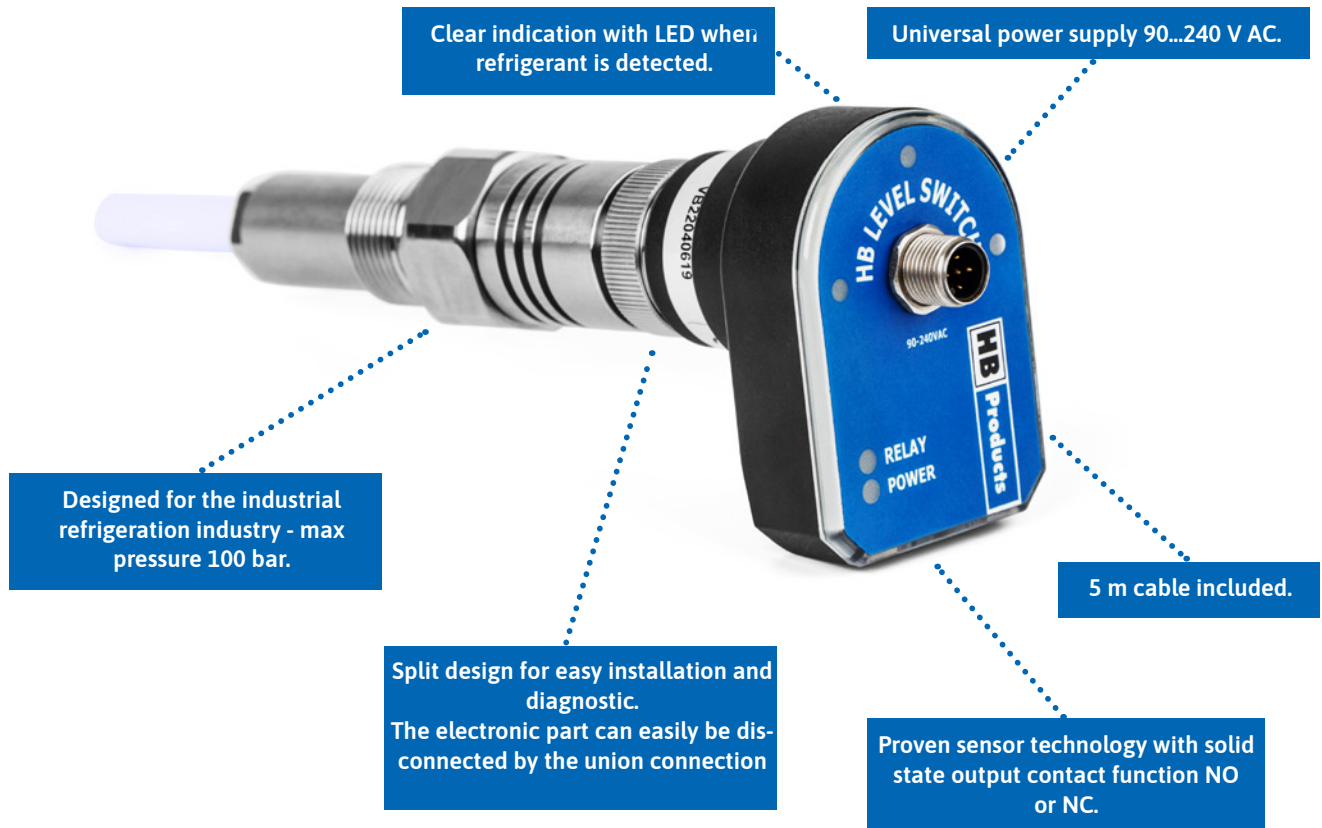

## Functional description

HBSR-U-SSR2 is a level switch for the detection of NH<sub>3</sub> and Brine refrigerants.

Typically it is installed in/on the refrigerant vessels, pump separators, economizers or heat exchangers.

The sensor is specially built to resist high pressure and low temperature.

The switch has a built-in local power supply for direct use on grid supply 90...240 V AC. A solid state relay can also operate a valve directly.

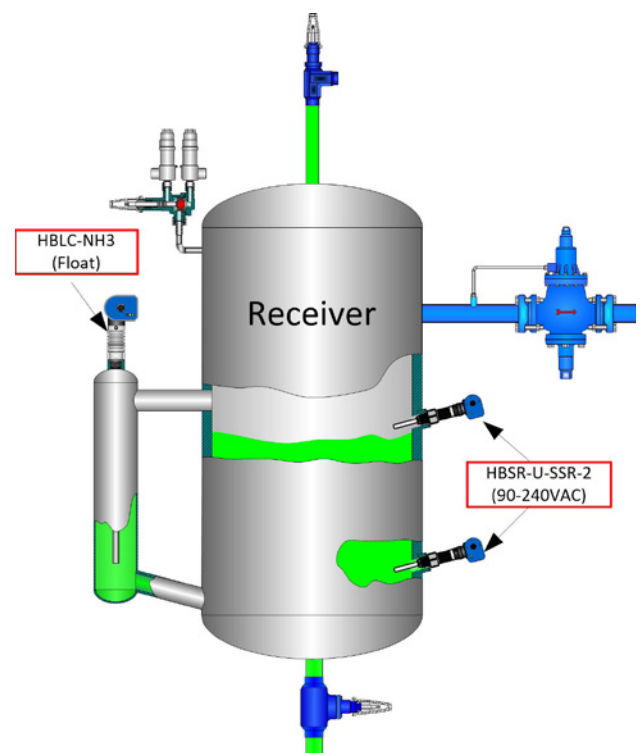

### Technical data

Power supply		Mechanical specifications	
Voltage	90...240 V AC	Thread connection	3/4" NPT / BSPP
Current consumption - sensor only*	<10 mA	Material – mechanical parts	AISI 304 / PTFE
Plug connection	M12 - DIN 0627	Material – electronic parts	Nylon 6 (PA)
Output		Dimensions	See drawing
Solid state relay output	90...240 V AC – 40 W	Environmental conditions	
Output function	NC or NO	Ambient temperature	-30...+50°C
Indication		Refrigerant temperature	-60...+80°C
Level indication	3 x LED (green)	Max pressure	100 bar
Power supply	1 x LED (green)	Protection degree	IP66
Relay-on activation	1 x LED (yellow)	Vibrations	IEC 68-2-6 (4g)
Cable specification (power supply)		Accessories	(To be ordered separately)
Cable size	5m - 3 x 0.25 mm <sup>2</sup>	Adapter - 3/4" NPT / 1" BSPP	HBS/ADAP/8/2
Cable glands	PG7 / M8	Adapter - 3/4" BSPP / 1" BSPP	HBS/ADAP/8/6
Cable resistance	500 Ω/Km		
Approvals			
CE	EN 61000-2		

\* Total consumption is sensor consumption plus output and it depends on ambient temperature.

### Mechanical dimensions

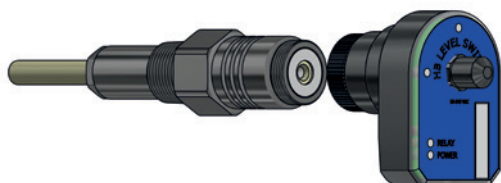
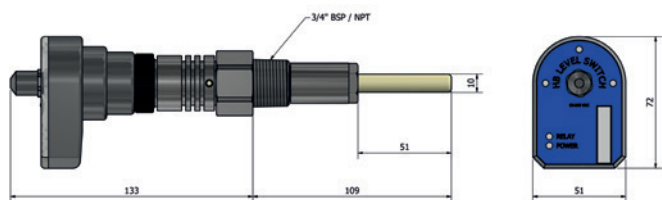

### Spare parts for HBSR-U-SSR2

Position	Specification	Type	Ordering code
1	Electronic parts	NO	HBSR-U-SSR2/NO-EL
		NC	HBSR-U-SSR2/NC-EL
2	Mechanical parts	3/4" NPT	HBSR-U-MEK-2
		3/4" BSPP	HBSR-U-MEK-6

### Spare parts for HBSR-SSR-2

Position	Specification	Type	Ordering code
1	Electronic parts	NO	HBSR-SSR-2/NO-EL
		NC	HBSR-SSR-2/NC-EL

### Ordering codes

Output	Thread type (G)	Ordering code
Solid state relay - NO	3/4" NPT	HBSR-U-SSR2/NO-2
Solid state relay - NO	3/4" BSPP	HBSR-U-SSR2/NO-6
Solid state relay - NC	3/4" NPT	HBSR-U-SSR2/NC-2
Solid state relay - NC	3/4" BSPP	HBSR-U-SSR2/NC-6

# NH<sub>3</sub> Liquid Level Switch - Low temperature

Category: HBSR-U-SSR-1/IP

Designed for the industrial refrigeration industry - max pressure up to 100 bar.

5 m cable included.

Split design that makes it possible to mount and perform a diagnostic without emptying the tanks for refrigerant.



Clear LED indication at level detection.

Reliable design with electronic solid state output and contact function NO or NC.

## Functional description

HBSR-SSR-1/IP Refrigerant Switch with built-in heater to protect against condensation at low temperatures. The switch is suited for use in freezers and for outdoor applications. It will typically be used for control of refrigerant liquid supply to separators. It is also used to control drainage of the liquid refrigerant during hot gas defrost.

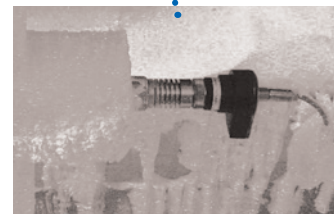
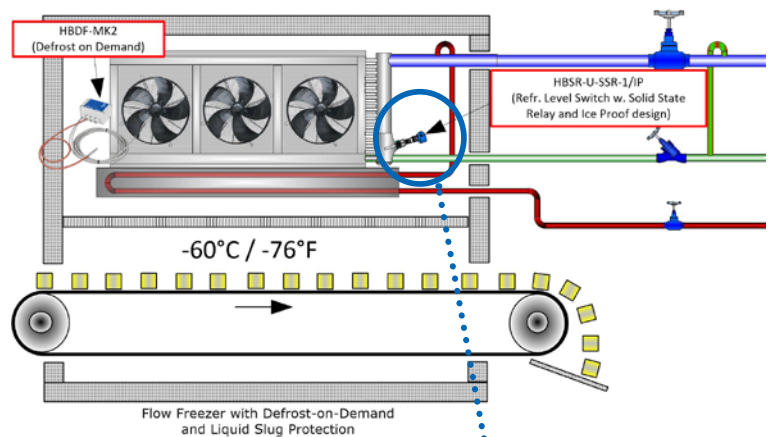

### Technical data

Power supply		Mechanical specifications	
Voltage	24 V DC ±10%	Thread connection	3/4" NPT/BSPP
Current consumption - sensor only*	Max 600 mA	Material – mechanical parts	AISI 304 / PTFE
Plug connection	M12, 5 pins - DIN 0627	Material – electronic parts	Nylon 6 (PA)
		Dimensions	210x52x40
Output		Environmental conditions	
Output type	SSR- 1A / 24 V AC/DC	Ambient temperature	-60...+50°C
Output function	NC or NO	Refrigerant temperature	-60...+80°C
LED indication	Green, yellow, and red	Max pressure	100 bar
Cable specification (power supply)		Protection degree	IP66
Cable size	5m - 3 x 0.34 mm <sup>2</sup>	Vibrations	IEC 68-2-6 (4g)
Cable glands	PG7 / M8		
Cable resistance	500 Ω/Km		
Approvals			
CE	EN 61000-2		

\* Total consumption is sensor consumption plus output and it depends on ambient temperature.

### Mechanical dimensions

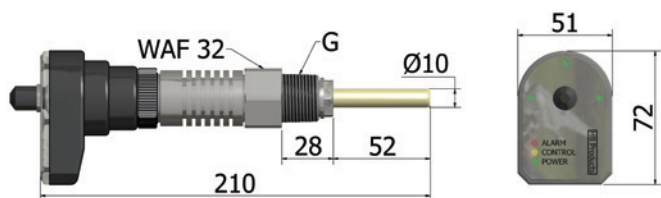

### Ordering codes

Output	Thread type	Ordering code
NC	3/4" NPT	HBSR-U-SSR-1/IP-NC-2
NO	3/4" NPT	HBSR-U-SSR-1/IP-NO-2
NC	3/4" BSPP	HBSR-U-SSR-1/IP-NC-6
NO	3/4" BSPP	HBSR-U-SSR-1/IP-NO-6
NC	1" BSPP	HBSR-U-SSR-1/IP-NC-8
NO	1" BSPP	HBSR-U-SSR-1/IP-NO-8

### Spare parts

Position	Specification	Type	Ordering code
1	Electronic parts	NO	HBSR-U-SSR-1/NO/IP-EL
		NC	HBSR-U-SSR-1/NC/IP-EL
2	Mechanical parts	3/4" NPT thread	HBSR-U-MEK-IP-2
		3/4" BSPP thread	HBSR-U-MEK-IP-6
		1" BSPP thread	HBSR-U-MEK-IP-8

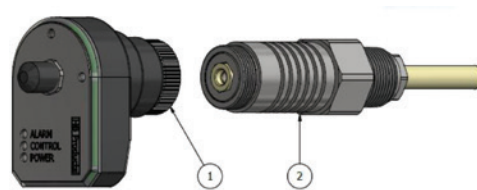

# NH<sub>3</sub>/CO<sub>2</sub> Leakage Switch

Category: HBAC-U\* / HBAC\*\*



HBAC-U Leakage Switch



HBX Leakage Sensor (identical to an HBX Vapor Quality Sensor)

## Functional description

In **CO<sub>2</sub>/NH<sub>3</sub> Cascade Refrigeration Systems** leakage of CO<sub>2</sub> into NH<sub>3</sub> creates ammonia carbamate which is a corrosive salt. A leakage will create severe damage in a refrigeration system and must be stopped as soon as possible.

Two sensors are available for this application:

- **HBAC-U /HBAC** is used in shell and tube applications where the sensor is mounted in the bottom of the vessel.
- **HBX** is used in the outlet of a plate heat exchanger and is a vapor quality sensor with special settings.

Both sensors trigger an alarm if CO<sub>2</sub> leak into the NH<sub>3</sub> part and the sensor detects even very small leaks.

### HBAC-U /HBAC

In a shell and tube heat exchanger the sensor is mounted in a low point in the liquid ammonia and reacts quickly on the formation of ammonia carbamate. The built-in alarm function is used to stop the refrigeration plant or to close the stop valves to reduce the system damages.

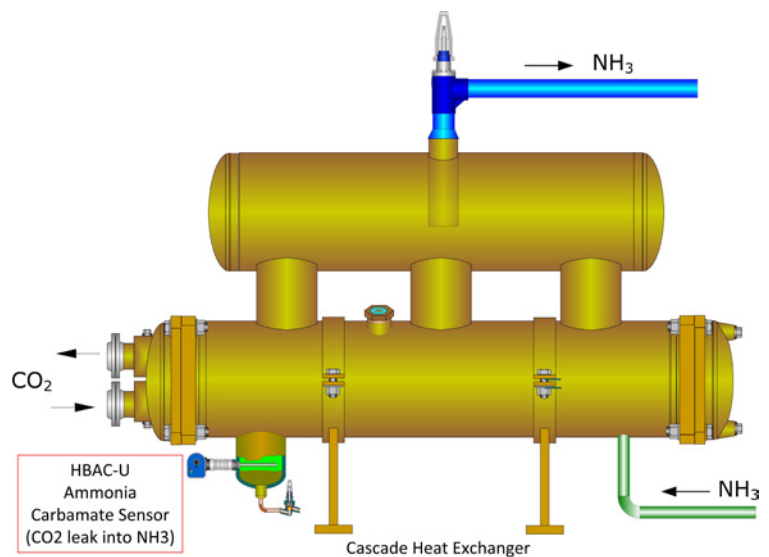

\* HBAC- U is the latest version. The electronic part can be disconnected by a union.

\*\* HBAC the electronic part can be disconnected by two screws.

## Technical data for HBAC-U

Power supply		Mechanical specifications	
Voltage	24 V AC/DC ±10%	Thread connection	¾" NPT / BSPP
Current consumption - sensor only*	Max 50 mA	Material - mechanical parts	AISI 304 / PTFE
		Material - electronic parts	Nylon 6 (PA)
Electrical connection	M12 - DIN 0627	Dimensions	210x52x40
Output		Environmental conditions	
Output type	PNP, 1 A	Ambient temperature	-30...+50°C
Output function	NC or NO	Refrigerant temperature	-60...+80°C
LED indication	Green & red	Max pressure	100 bar
Cable specification (power supply)		Protection degree	
Cable size	5m - 3 x 0.34 mm <sup>2</sup>	Vibrations	IEC 68-2-6 (4g)
Cable glands	PG7 / M8	Approvals	
Cable resistance	500 Ω/Km	CE	EN 61000-2

\* Total consumption is sensor consumption plus output and it depends on ambient temperature.

## Mechanical dimensions for HBAC-U

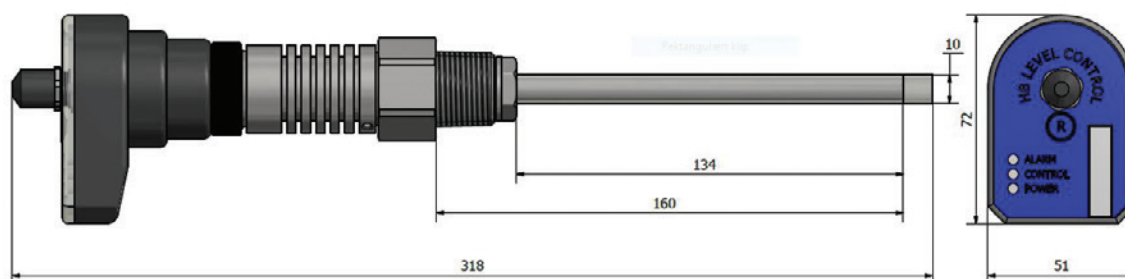

## Spare parts for HBAC-U

Output	Thread type (G)	Ordering code
NO	¾" NPT	HBAC-U-1.6-NO-2
NC	¾" NPT	HBAC-U-1.6-NC-2
NO	¾" BSPP	HBAC-U-1.6-NO-6
NC	¾" BSPP	HBAC-U-1.6-NC-6

## Ordering codes for HBAC-U

Position	Specification	Type	Ordering code
1	Electronic parts	NO	HBAC-U-EL-NO
		NC	HBAC-U-EL-NC
2	Mechanical parts	¾" NPT	HBLC-U-MEK-1.6-2
		¾" BSPP	HBLC-U-MEK-1.6-6

## Spare parts for HBAC

Position	Specification	Type	Ordering code
1	Electronic parts	NO	HBAC-EL-NO
		NC	HBAC-EL-NC



# Ammonia Carbamate detection in Strainer Housing

## Category: HBAC-ST

For plate heat exchangers an HBAC sensor in strainer housing can be specified for detecting ammonia carbamate.

An alarm setting in the sensor will provide a digital output, when ammonia carbamate is detected, alternatively the analog output can provide the same information to a PLC as a high mA signal.

The HBAC sensor in strainer housing can be supplied with a filter on request. The sensor can also be combined with a vapor quality sensor function for optimal control of the plate heat exchanger.

For technical data and mechanical dimensions for the strainer house solution please go to **page 23**.



## Ordering codes for HBAC-ST

Size	Ordering code	
	Carbon steel	Stainless steel
DN20	HBAC-ST-DN20	HBAC-ST-DN20-SS
DN25	HBAC-ST-DN25	HBAC-ST-DN25-SS
DN32	HBAC-ST-DN32	HBAC-ST-DN32-SS
DN40	HBAC-ST-DN40	HBAC-ST-DN40-SS
DN50	HBAC-ST-DN50	HBAC-ST-DN50-SS
DN65	HBAC-ST-DN65	HBAC-ST-DN65-SS
DN80	HBAC-ST-DN80	
DN100	HBAC-ST-DN100	
DN125	HBAC-ST-DN125	
DN150	HBAC-ST-DN150	
DN200	HBAC-ST-DN200	
DN250	HBAC-ST-DN250	
DN300	HBAC-ST-DN300	

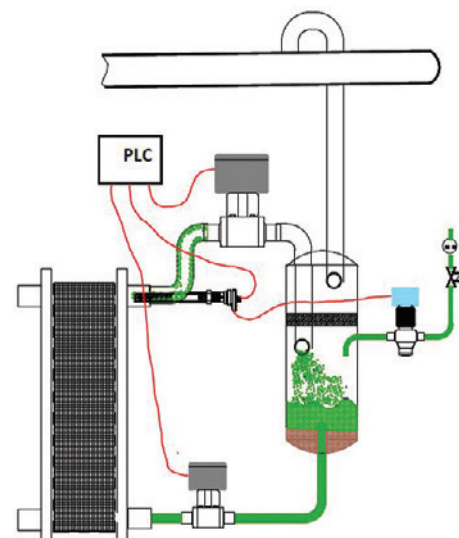

Detects ammonium carbamate in a NH<sub>3</sub> systems



# Compressor Protection

Category: HBCP



HBCP



HBCP-ST (HBCP in strainer housing)

## Functional description

HBCP is a variant of the HBX vapor quality sensor used at the compressor inlet. HBCP can provide an alarm, when the liquid content in the gas exceeds the critical set point or simply provides an analog signal to a PLC. The sensor can prevent liquid refrigerant from entering the compressor, causing damage to the moving parts. The sensor has a high sensitivity and detects even small liquid droplets before they become critical to the compressor. The sensor has a uniquely short reaction time which can be used for emergency stop of the compressor, but typically the signal can be used as an early warning or as a part of the evaporator control.

Two types are available: The rod style sensor, which is installed in a pipe elbow or the strainer house version. The strainer house solution is easier to install correctly.

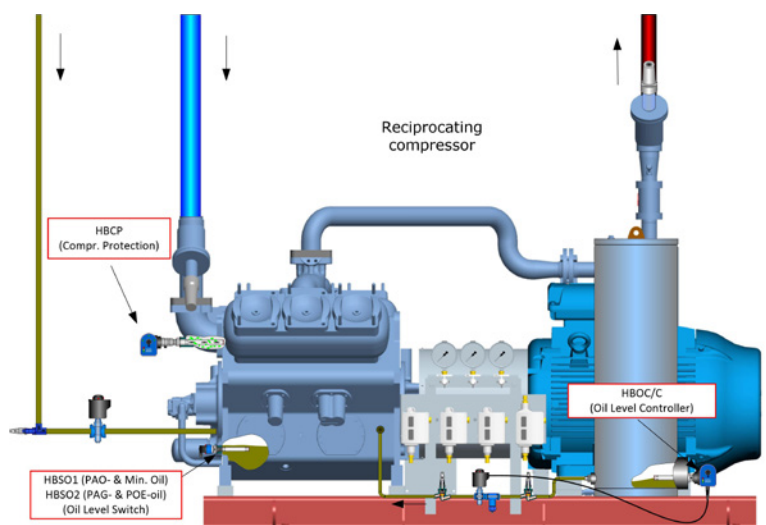

## Technical data for HBCP

Power supply		Mechanical specifications	
Voltage	24 V AC/DC ±10%	Thread connection	3/4" & 1" NPT / BSPP
Current consumption - sensor only*	600 mA	Material - mechanical parts	AISI 304 / PTFE
Plug connection	M12, 5 pins - DIN 0627	Material - electronic parts	Nylon 6 (PA)
		Dimensions	See drawing
Output		Environmental conditions	
Output type	PNP-1 A	Ambient temperature	-30...+50°C
Output function	NC or NO	Refrigerant temperature	-60...+40°C
LED indication	Green, yellow, and red	Max pressure	100 bar
Cable specification (power supply)		Protection degree	IP65
Cable size	5m - 3 x 0.25 mm <sup>2</sup>	Vibrations	IEC 68-2-6 (4g)
Cable glands	PG7 / M8	Approvals	
Cable resistance	500 Ω/Km	CE	EN 61000-2
Configuration			
Type of configuration	HB Tool		
Tool to be used	HBCP or HBX software		

\* Total consumption is sensor consumption plus output and it depends on ambient temperature.

## Mechanical dimensions for HBCP

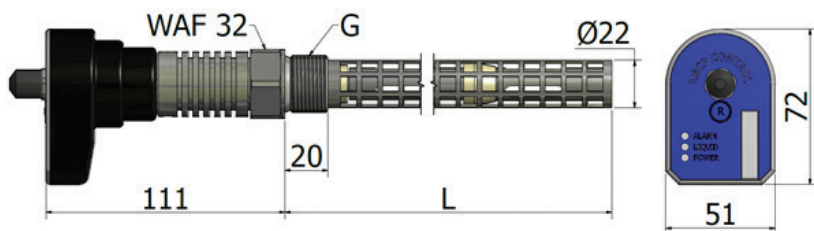

## Ordering codes for HBCP

Pipe size (compressor line)	Length (L)	Connection	Ordering code
< 2"	150 mm	3/4" NPT	HBCP-1.5-2
< 2"	150 mm	3/4" BSPP	HBCP-1.5-6
> 2"	300 mm	3/4" NPT	HBCP-3-2
> 2"	300 mm	3/4" BSPP	HBCP-3-6
> 2"	300 mm	1" NPT	HBCP-3-9
> 2"	300 mm	1" BSPP	HBCP-3-8

## Spare parts for HBCP

Position	Specification	Type	Ordering code
1	Electronic part	PC-programmable	HBCP-EL
2	Mechanical parts	3/4" NPT	HBCP-2-MEK
		3/4" BSPP	HBCP-6-MEK
		1" NPT	HBCP-9-MEK
		1" BSPP	HBCP-8-MEK

# Compressor Protection in strainer housing

## Category: HBCP-ST

To help you install the Compressor Protection Sensor correctly we recommend using an HBCP-ST Sensor in strainer housing. Physically the HBCP-ST sensor is identical to the HBX sensor. The difference between the two sensors are the configuration, which can be customized to your system.

For technical data, mechanical dimensions for the strainer house solution please go to [page 23](#).



## Ordering codes for HBCP-ST

Size	Ordering code	
	Carbon steel	Stainless steel
DN20	HBCP-ST-DN20	HBCP-ST-DN20-SS
DN25	HBCP-ST-DN25	HBCP-ST-DN25-SS
DN32	HBCP-ST-DN32	HBCP-ST-DN32-SS
DN40	HBCP-ST-DN40	HBCP-ST-DN40-SS
DN50	HBCP-ST-DN50	HBCP-ST-DN50-SS
DN65	HBCP-ST-DN65	HBCP-ST-DN65-SS
DN80	HBCP-ST-DN80	
DN100	HBCP-ST-DN100	
DN125	HBCP-ST-DN125	
DN150	HBCP-ST-DN150	
DN200	HBCP-ST-DN200	
DN250	HBCP-ST-DN250	
DN300	HBCP-ST-DN300	

# NH<sub>3</sub> Liquid Level Sensor - Wire

## Category: HBLT-W-Wire & HBSLT-W-Wire

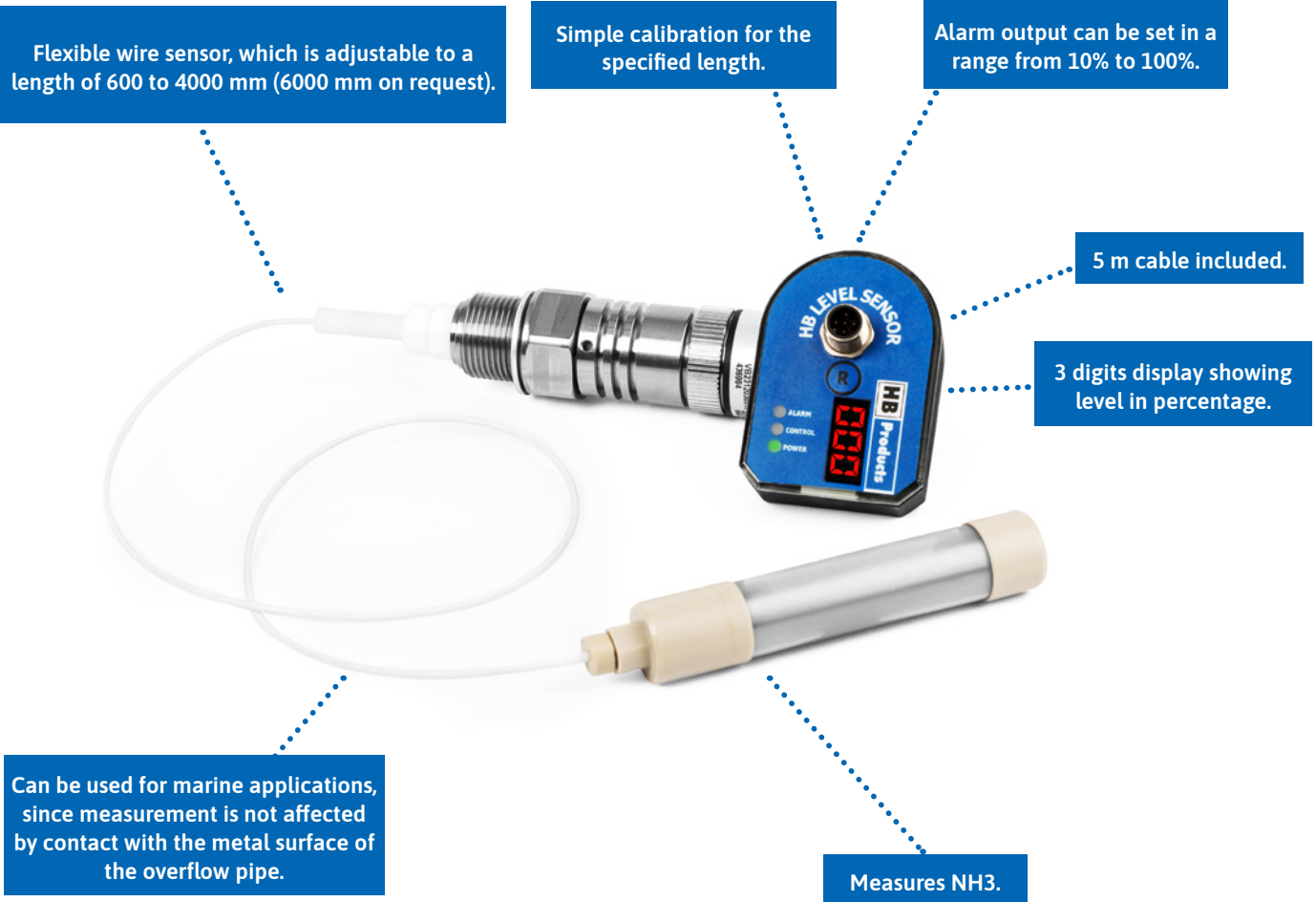

### Functional description:

HBLT-W-WIRE is a capacitive sensor for level measurement of NH<sub>3</sub> refrigerant in industrial refrigeration systems. The sensor has an output signal of 4-20 mA, which is proportional with 0 to 100%. The output signal is 4 mA for an empty vessel and 20 mA for a full vessel. HBLT-W-WIRE can be adjusted in length to the current application. The sensor element consists of a 2 mm preisolated steel wire. Both parts are provided with a length of 4 m and can be shortened with diagonal cutters or other pliers. HBLT-wire can be used in connection with the HBLT-C1 controller for controlling pumps, etc., or it can be configured to directly control a valve without the need for another controller. Also available with integrated cable for direct control of any type of liquid valve.

The sensor is delivered in a version without integrated cable (named HBLT-WIRE) and a version with cable for direct control of valves (named HBSLT-WIRE).



- Available as 2-wire sensor
- Now with ATEX / IECEx certificate (This version is without LED display)

## Use of HBLT-Wire sensor

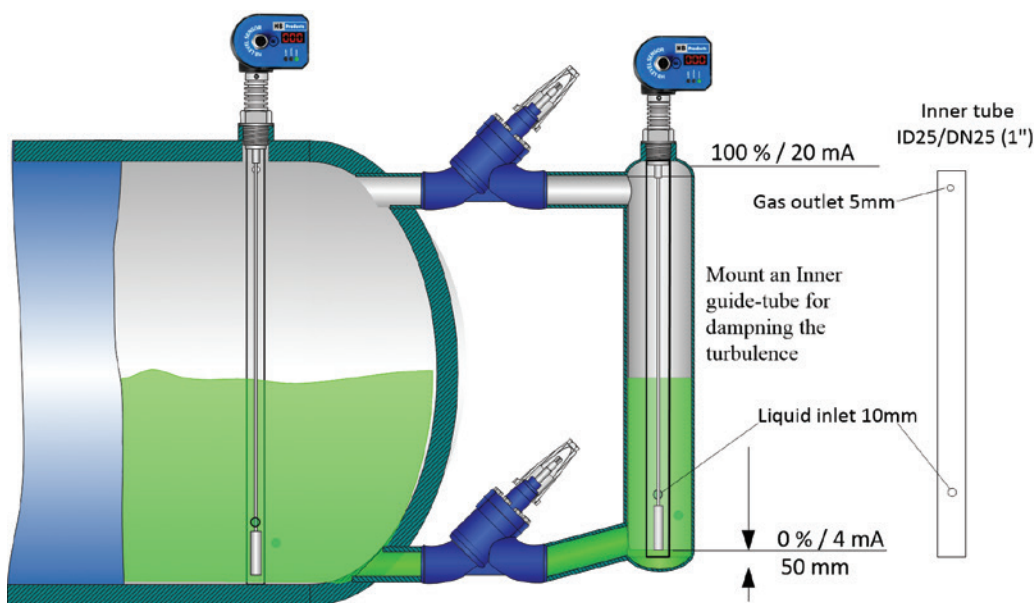

When using a level sensor for measuring Ammonia in a compact plate and shell heat exchanger or other systems with turbulent conditions, we have new recommendation based on recent experience:

### Stand-pipe construction:

- It is essential to secure drainage of oil from the standpipe. The drainage outlet must be below the lowest sensor point and the outlet should have a slope towards the tank. A collection of oil in the standpipe will disturb the measurement.

### For Stand-pipes with stable conditions (smooth changes in the level):

- Use a HBLT-Wire, a HBLT-A1 rod style sensor or a HBLT-A2 rod style sensor.

### For Stand-pipes with turbulent conditions (a lot of turbulence, cooking, foaming, liquid from the top):

- Use a HBLT-A2 rod-style sensor, or
- Use only a HBLT-Wire sensor when you have it mounted in an inner guide-tube of e.g. DN25 as illustrated. The guide-tube will dampen the turbulence and the foaming and you will have a good measurement.
- If HBLT-Wire sensor is already mounted under these conditions WITHOUT a guide-tube, do eventually set the filter time function between 60-120 seconds to dampen the signal from the turbulent conditions.

### For tank/drum installation:

- Use a HBLT-A1 rod-style sensor, or
- Use only a HBLT-Wire sensor when you have it mounted in an inner guide-tube of e.g. DN25 as illustrated. The guide-tube will dampen the level and the foaming and you will have a good measurement.
- If HBLT-Wire sensor is already mounted under these conditions WITHOUT a guide-tube, do eventually set the filter time function between 60-120 seconds to dampen the signal from the turbulent conditions.

### For Alfa Laval U-turn evaporator:

- Use an HBLT-A2 rod-style sensor.

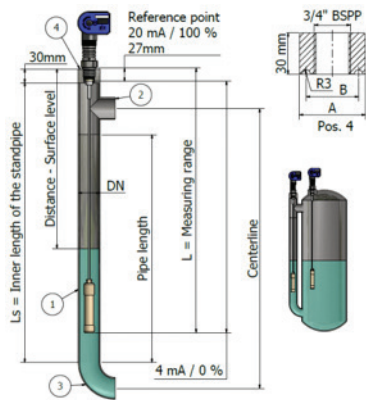

Stand pipe: DN32.....DN65.  
 Recommended pipe standard: DIN 10220  
 Recommended bending: DIN 2615-1/Type 3  
 Recommended TEE: DIN 2615-1

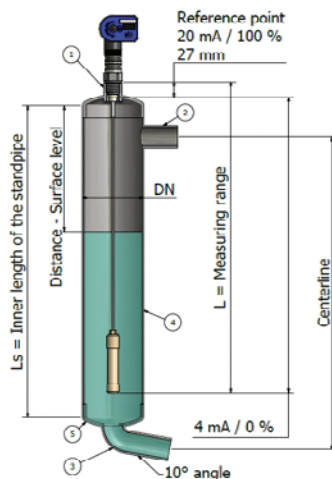

Standpipe: DN65...DN100.  
 Recommended pipe standard: DIN 10220  
 Recommended bending: DIN 2615-1/  
 Type 3  
 Site pipe can be designed in smaller pipe  
 e.g. 0.5 x DN.

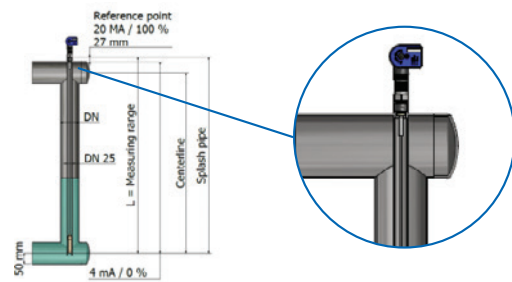

If the sensor is installed in standpipe on front of plate heat exchanger with return liquid flow the wire must be protected against splashing with a protection tube size DN25..DN32.

If a splashing pipe is not installed, the filter time can be changed to 120 sec. See separate manual for sensor configuration.

**Technical data**

Power supply		Mechanical specifications	
Voltage	24 V AC/DC + 10%	Thread connection	3/4" NPT/BSPP
Current consumption - sensor only*	Max 50 mA	Material - mechanical parts	AISI 304 / PTFE
		Material - electronic parts	Nylon 6 (PA)
Plug connection	M12, 5 pins - DIN 0627	Dimensions	See drawing
Output		Environmental conditions	
Analog output	4-20 mA	Ambient temperature	-30...+50°C (IP version: -60...+50°C)
Alarm output	1A (24V DC)	Refrigerant temperature*	-60...+80°C
LED indication	Green, yellow, and red	Max pressure	100 bar
Max. possible resistance	500 ohm	Protection degree	IP65
Cable specification (power supply)		Vibrations	IEC 68-2-6 (4g)
Cable size	5 m - 3 x 0.25 mm2	Accessories	<b>(To be ordered separately)</b>
Cable glands	PG7 / M8	Adapter - 3/4" NPT / 1" BSPP	HBS/ADAP/8/2
Cable resistance	500 Ω/Km	Adapter - 3/4" BSPP / 1" BSPP	HBS/ADAP/8/6
Approvals		Configuration tool	
CE	EN 61000-2	Plug converter	HBxC-M12/DIN
EAC Regulation of Conformity			
Configuration			
Type of configuration	HB Tool/HMI		
Tool to be used	HBLT-Wire software		

\* Total consumption is sensor consumption plus output and it depends on ambient temperature.

### Ordering codes

Length	Thread type	Without integrated cable	Modulating valve*	Stepper motor valve**	Pulse width modulation***
600 – 4000 mm	3/4" NPT	HBLT-W-WIRE-2	HBSLT-W-WIRE/C-2	HBSLT-W-WIRE/S-2	HBSLT-W-WIRE/PWM-2
600 – 4000 mm	3/4" BSPP	HBLT-W-WIRE-6	HBSLT-W-WIRE/C-6	HBSLT-W-WIRE/S-6	HBSLT-W-WIRE/PWM-6
600 - 6000 mm	3/4" NPT	HBLT-W-WIRE-6-2	HBSLT-W-WIRE/C-6-2	HBSLT-W-WIRE/S-6-2	HBSLT-W-WIRE/PWM-6-2
600 - 6000 mm	3/4" BSPP	HBLT-W-WIRE-6-6	HBSLT-W-WIRE/C-6-6	HBSLT-W-WIRE/S-6-6	HBSLT-W-WIRE/PWM-6-6
600 – 4000 mm	3/4" NPT	HBLT-W-WIRE-2-IP****			
600 – 4000 mm	3/4 BSPP	HBLT-W-WIRE-6-IP			

\*For direct control of a modulating valve such as Siemens MVS661.

\*\*For direct control of a stepper motor valve such as Carel.

\*\*\*For direct control of a pulse width modulation valve such as Danfoss AKVA.

\*\*\*\*HBLT-WIRE-IP is a low temperature version.

### Mechanical dimensions

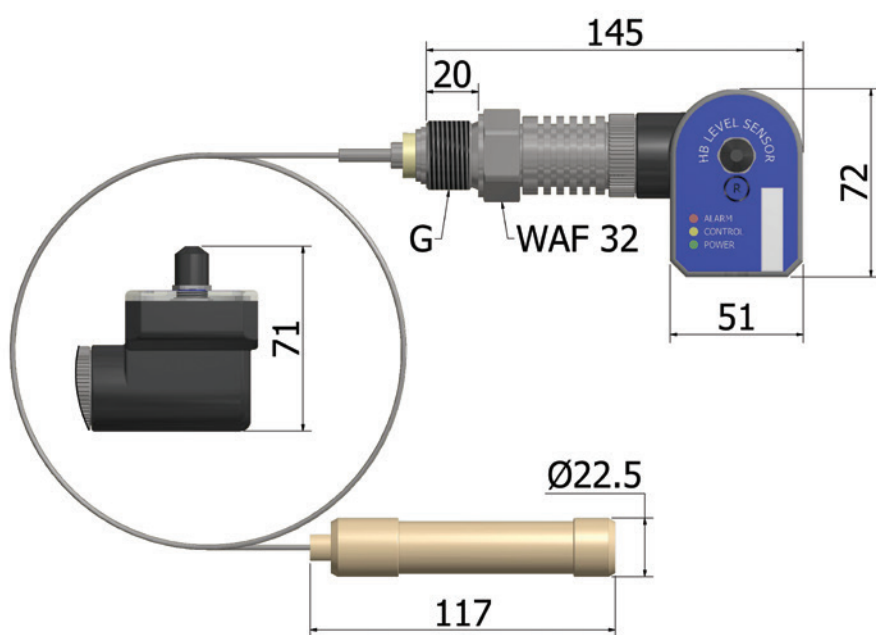



## HBLT-WIRE - Counterweight with adjustable center position spring

Under turbulent conditions, the counterweight for the HBLT-WIRE can be supplied as a spare part with an adjustable center position spring. The center position spring is delivered with cutting marks so it can be adapted and cut to the dimension of the stand pipe..

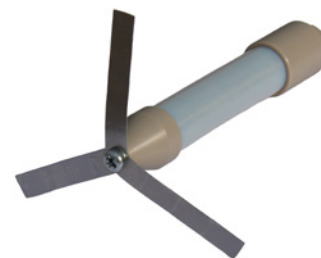

### Spare parts

Position	Specification	Type/Thread	Ordering code
1	Electronic parts	PC-programmable	HBLT-Wire-EL
		PC-programmable - for modulating valve	HBLT-WIRE/C-EL
		PC-programmable - for stepper motor	HBLT-WIRE/S-EL
		PC-programmable - for low temperature	HBLT-WIRE-EL-IP
2	Mechanical parts	3/4" NPT	HBLT-WIRE-MEK-2
		3/4" BSPP	HBLT-WIRE-MEK-6
		3/4" NPT	HBLT-WIRE-MEK-6-2
		3/4" BSPP	HBLT-WIRE-MEK-6-6
3	Wire plumb	Dimensions: Ø22.5x115 mm	HBLT-WIRE-PLUMB
4	Counterweight	Dimensions: Ø to be adjusted x 127mm	HBLT-W-COUNTERWEIGHT
5	Thread Adapter	1"BSPP -> 3/4"BSPP adap. W. alu gasket	HBS/ADAP/8/6

\*HBLT-WIRE/C is with LED-display and integrated cable for control of modulating valve.

\*HBLT-WIRE/S is with integrated cable for control of stepper motor regulation. This version does not have LED-display.

\*HBLT-WIRE-IP is a low temperature version.

# NH<sub>3</sub> Liquid Level Transmitter

## Category: HBLT-A2 & HBSLT-A2

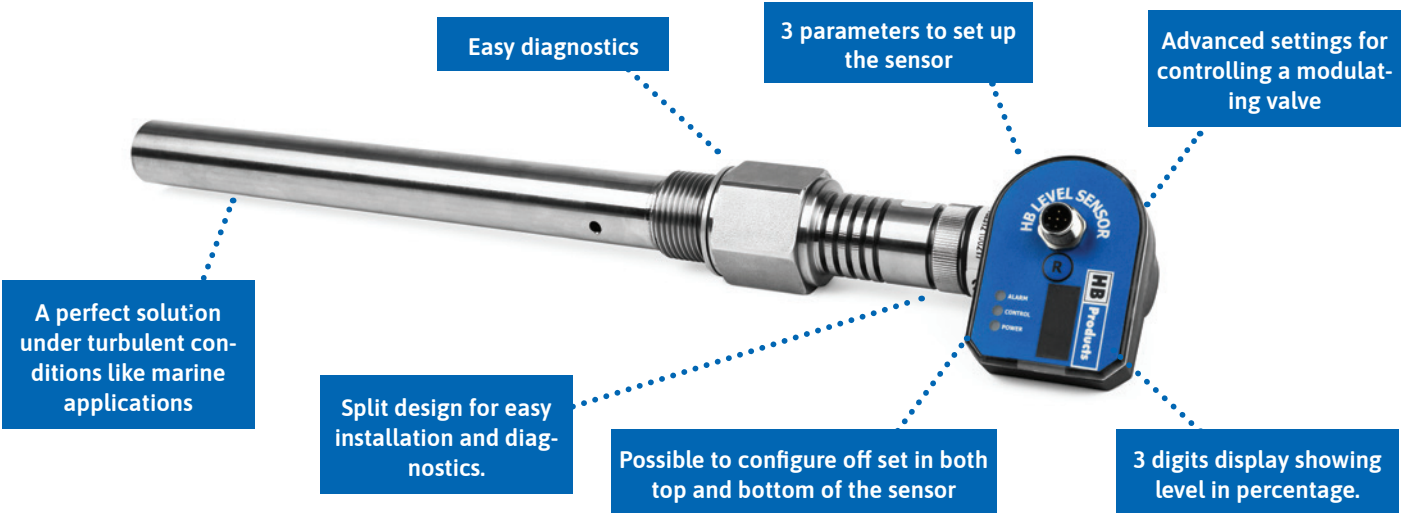

### Functional description

HBLT-A2 capacitive liquid level sensors are used to measure liquid levels in refrigerant vessels. The sensor transmits a current signal from 4 to 20 mA (4 mA when the transmitter does not register liquid - and 20 mA when the entire transmitter is surrounded by liquid).

The difference between the new HBLT-A2 and the HBLT-A1 is the electronic head. We have used the electronic head from our HBLC sensor, which gives more opportunities in the HB Tool for configuration with 3 parameters to set up the sensor. HBLT-A2 has a digital display instead of the bar graph known from HBLT-A1 and HBLT-A2 is an intelligent sensor with a built-in microprocessor. It emits a 4-20 mA signal, which is proportional to the sensor's set range of measurement. Apart from the 4-20 mA signal the sensor also has a built-in controller. The controller can be set-up with all the parameters necessary for controlling a modulating motor valve. The sensor can be delivered with a cable for direct supply to and control of motor valves.

The sensor is delivered in a version without integrated cable (named HBLT) and a version with cable for direct control of valves (named HBSLT).

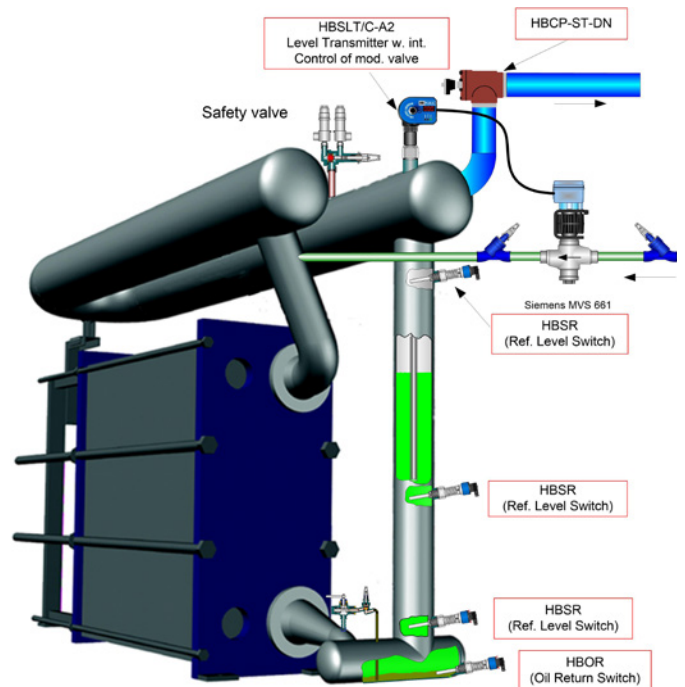

HBLT/C-A2, here is a cable connection directly to a modulating liquid valve such as Siemens MVS661, this will save installations cost because there is built in a level controller in the sensor head.

**HBLT-A2 provides new possibilities but is available to the same price as HBLT-A1**



- Available as 2-wire sensor
- Now with ATEX / IECEx certificate (This version is without LED display)

## Technical data

Power supply		Mechanical specifications	
Voltage	24 V AC/DC $\pm$ 10 % *	Thread connection	$\frac{3}{4}$ " NPT & 1" BSPP
Current consumption - sensor only*	250 mA	Material - mechanical parts	AISI304 / PTFE
Electrical connection	M12, 5 pins	Material - electronic parts	GF BLK Nylon 6 (PA)
		Housing design:	Front
Direct valve control		Configuration & indication	
/C: Signal to modulation valve	4-20 mA	Configuration	By HB Tool
/S: Integrated controller for stepper motor valve		LED indication	Green, yellow, and red
Alarm output	1A (24V DC)		
Environmental conditions		Cable specification:	
Ambient temperature	-30...+50°C	Supply cable, 5 meters	HBxC-M12/5 Straight
Refrigerant temperature	-60...+80°C	Cable size	5 x 0,34 mm <sup>2</sup>
Max. operational pressure	100 bar		
Protection degree	IP 65		
Authorisations		Accessories	
Vibrations	IEC 68-2-6 (4g)	Modulating valve	Siemens MVS 661
EMC Emission	EN61000-3-2	Stepper motor valve	Carel E2V
EMC Immunity	EN61000-4-2	Adapter - $\frac{3}{4}$ " NPT / 1" BSPP	HBS/ADAP/8/2
EAC Regulation of Conformity:		Adapter - $\frac{3}{4}$ " BSPP / 1" BSPP	HBS/ADAP/8/6

\* Total consumption is sensor consumption plus output and it depends on ambient temperature.

## Mechanical dimensions

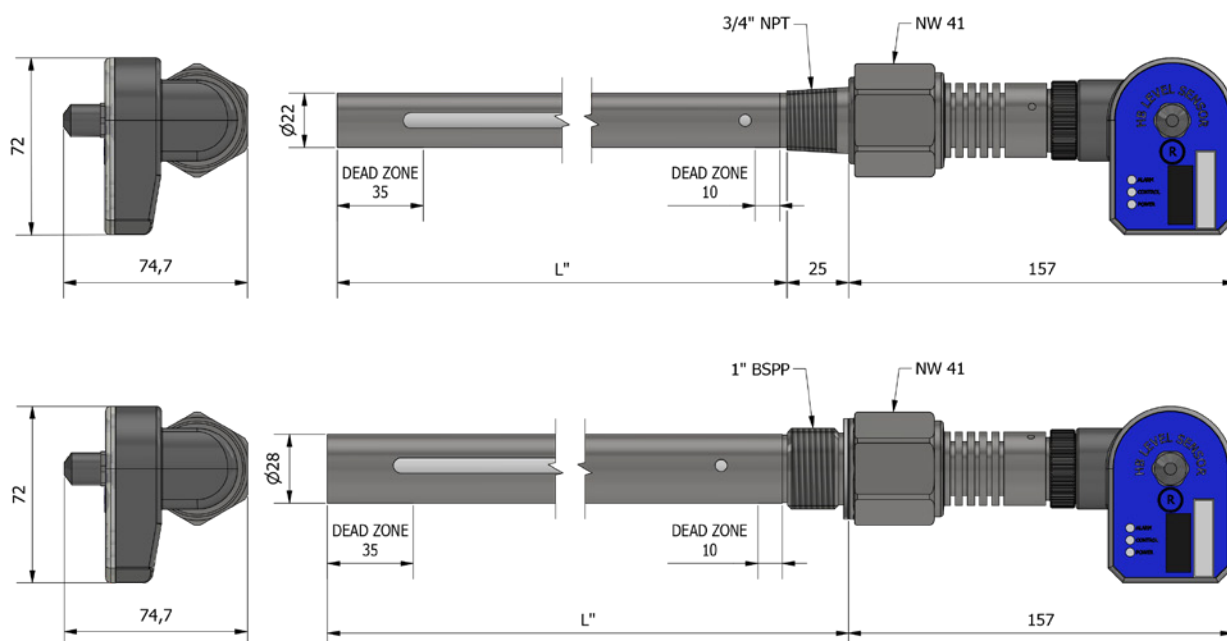

## Ordering codes

Length	Thread type	Without cable	Modulating valve*	Stepper motor**	Pulse width modulation***
280 mm	1" BSPP (G)	HBLT-A2-2.8	HBSLT/C-A2-2.8	HBSLT/S-A2-2.8	HBSLT/PWM-A2-2.8
500 mm	1" BSPP (G)	HBLT-A2-5	HBSLT/C-A2-5	HBSLT/S-A2-5	HBSLT/PWM-A2-5
800 mm	1" BSPP (G)	HBLT-A2-8	HBSLT/C-A2-8	HBSLT/S-A2-8	HBSLT/PWM-A2-8
1000 mm	1" BSPP (G)	HBLT-A2-10	HBSLT/C-A2-10	HBSLT/S-A2-10	HBSLT/PWM-A2-10
1200 mm	1" BSPP (G)	HBLT-A2-12	HBSLT/C-A2-12	HBSLT/S-A2-12	HBSLT/PWM-A2-12
1500 mm	1" BSPP (G)	HBLT-A2-15	HBSLT/C-A2-15	HBSLT/S-A2-15	HBSLT/PWM-A2-15
1700 mm	1" BSPP (G)	HBLT-A2-17	HBSLT/C-A2-17	HBSLT/S-A2-17	HBSLT/PWM-A2-17
2200 mm	1" BSPP (G)	HBLT-A2-22	HBSLT/C-A2-22	HBSLT/S-A2-22	HBSLT/PWM-A2-22
3000 mm	1" BSPP (G)	HBLT-A2-30	HBSLT/C-A2-30	HBSLT/S-A2-30	HBSLT/PWM-A2-30
6"	3/4" NPT	HBLT-A2-6U	HBSLT/C-A2-6U	HBSLT/S-A2-6U	HBSLT/PWM-A2-6U
8"	3/4" NPT	HBLT-A2-8U	HBSLT/C-A2-8U	HBSLT/S-A2-8U	HBSLT/PWM-A2-8U
12"	3/4" NPT	HBLT-A2-12U	HBSLT/C-A2-12U	HBSLT/S-A2-12U	HBSLT/PWM-A2-12U
15.3"	3/4" NPT	HBLT-A2-15.3U	HBSLT/C-A2-15.3U	HBSLT/S-A2-15.3U	HBSLT/PWM-A2-15.3U
19.2"	3/4" NPT	HBLT-A2-19.2U	HBSLT/C-A2-19.2U	HBSLT/S-A2-19.2U	HBSLT/PWM-A2-19.2U
23.1"	3/4" NPT	HBLT-A2-23.1U	HBSLT/C-A2-23.1U	HBSLT/S-A2-23.1U	HBSLT/PWM-A2-23.1U
30"	3/4" NPT	HBLT-A2-30U	HBSLT/C-A2-30U	HBSLT/S-A2-30U	HBSLT/PWM-A2-30U
35"	3/4" NPT	HBLT-A2-35U	HBSLT/C-A2-35U	HBSLT/S-A2-35U	HBSLT/PWM-A2-35U
45"	3/4" NPT	HBLT-A2-45U	HBSLT/C-A2-45U	HBSLT/S-A2-45U	HBSLT/PWM-A2-45U
55"	3/4" NPT	HBLT-A2-55U	HBSLT/C-A2-55U	HBSLT/S-A2-55U	HBSLT/PWM-A2-55U
65"	3/4" NPT	HBLT-A2-65U	HBSLT/C-A2-65U	HBSLT/S-A2-65U	HBSLT/PWM-A2-65U
85"	3/4" NPT	HBLT-A2-85U	HBSLT/C-A2-85U	HBSLT/S-A2-85U	HBSLT/PWM-A2-85U
105"	3/4" NPT	HBLT-A2-105U	HBSLT/C-A2-105U	HBSLT/S-A2-105U	HBSLT/PWM-A2-105U
120"	3/4" NPT	HBLT-A2-120U	HBSLT/C-A2-120U	HBSLT/S-A2-120U	HBSLT/PWM-A2-120U

\*For direct control of a modulating valve such as Siemens MVS661.

\*\*For direct control of a stepper motor valve such as Carel.

\*\*\*For direct control of a pulse width modulation valve such as Danfoss AKVA.

## Spare parts



Specification	Length	Thread type	Ordering code
Electronic parts			HBLT-A2-EL
For modulating valve			HBLT/C-A2-EL
For stepper motor			HBLT/S-A2-EL
Mechanical parts	6"	3/4" NPT	HBLT-MEK-6U
	8"	3/4" NPT	HBLT-MEK-8U
	12"	3/4" NPT	HBLT-MEK-12U
	15.3"	3/4" NPT	HBLT-MEK-15.3U
	19.2"	3/4" NPT	HBLT-MEK-19.2U
	30"	3/4" NPT	HBLT-MEK-30U
	35"	3/4" NPT	HBLT-MEK-35U
	45"	3/4" NPT	HBLT-MEK-45U
	55"	3/4" NPT	HBLT-MEK-55U
	65"	3/4" NPT	HBLT-MEK-65U
	85"	3/4" NPT	HBLT-MEK-85U
	105"	3/4" NPT	HBLT-MEK-105U
	120"	3/4" NPT	HBLT-MEK-120U
	280 mm	1" BSPP (G)	HBLT-MEK-2.8
	500 mm	1" BSPP (G)	HBLT-MEK-5
	800 mm	1" BSPP (G)	HBLT-MEK-8
	1000 mm	1" BSPP (G)	HBLT-MEK-10
	1200 mm	1" BSPP (G)	HBLT-MEK-12
	1500 mm	1" BSPP (G)	HBLT-MEK-15
	1700 mm	1" BSPP (G)	HBLT-MEK-17
	2200 mm	1" BSPP (G)	HBLT-MEK-22
	3000 mm	1" BSPP (G)	HBLT-MEK-30

# NH<sub>3</sub> Liquid Level Sensor

Category: HBLT-A1

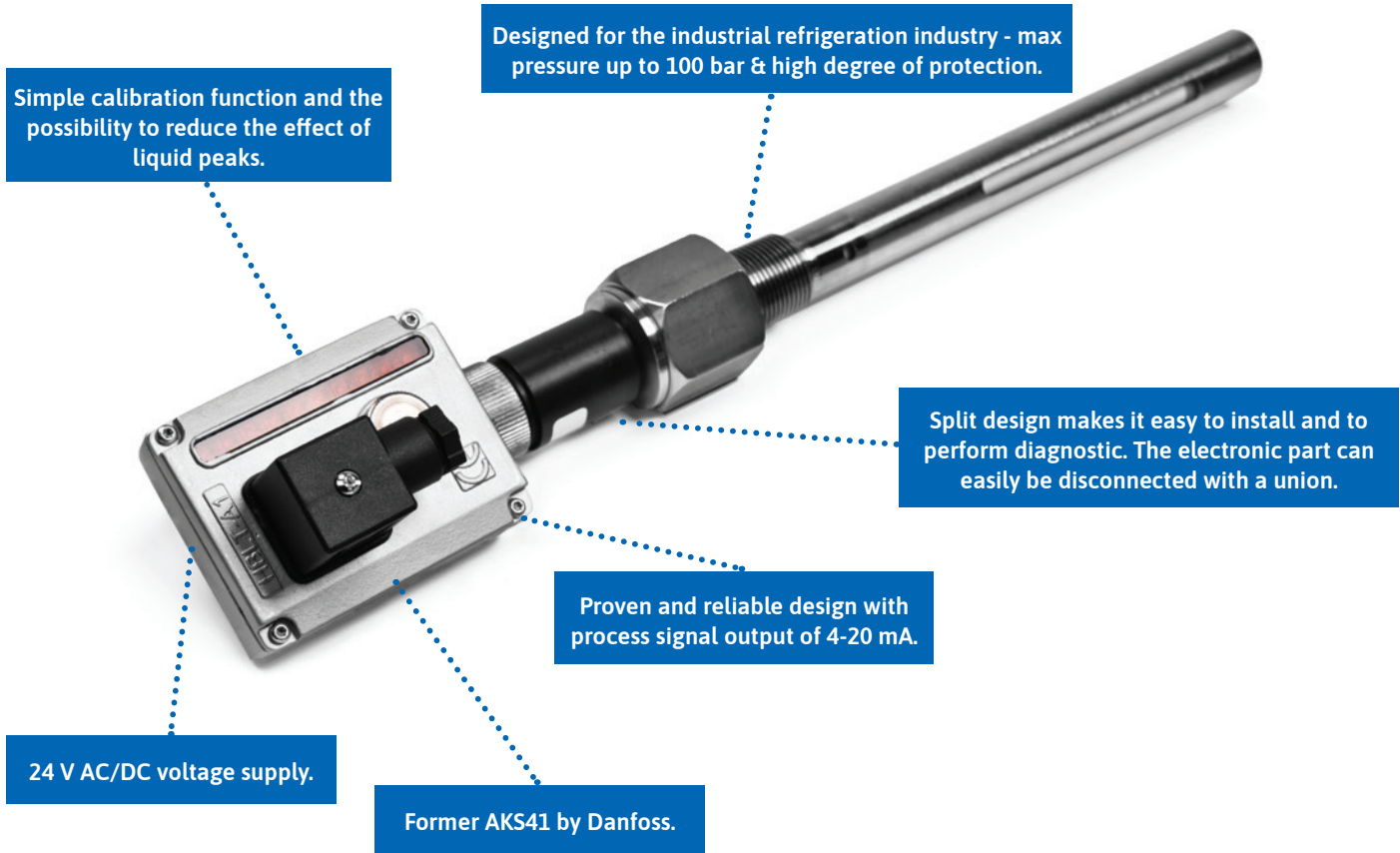

## Functional description:

HBLT capacitive liquid level transmitters are used to measure liquid levels in refrigerant vessels. The HBLT transmits an active 4-20 mA signal which is proportional to the liquid level. 4 mA when the transmitter does not register liquid and 20 mA when the entire transmitter is surrounded by liquid. The 4-20 mA signal from HBLT can be used in conjunction with a controller e.g. HBLT-C1 to control the liquid level.

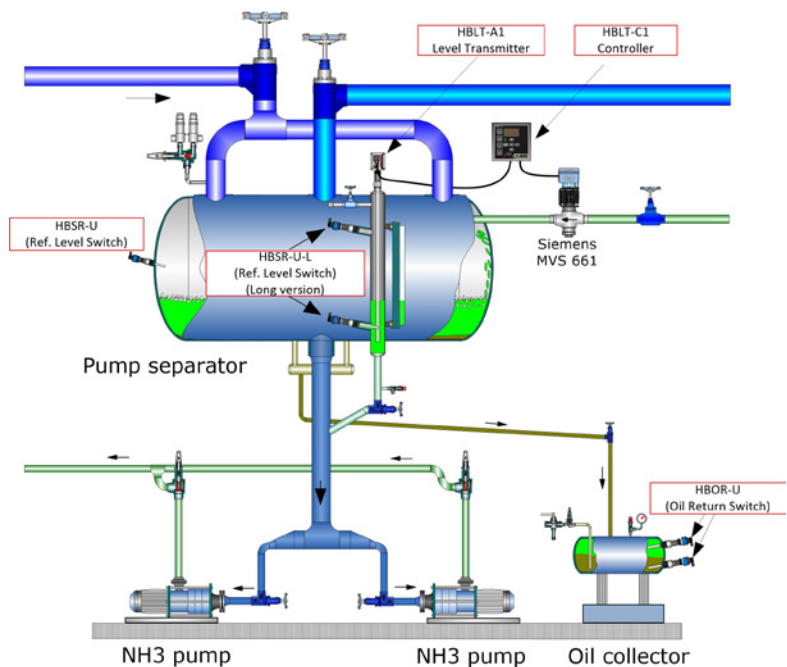

## Technical data

Power supply		Mechanical specifications	
Voltage	24 V AC/DC + 10%	Thread connection	3/4" NPT & 1" BSPP
Current consumption - sensor only*	Max 50 mA	Material - mechanical parts	AISI 304 / PTFE
		Material - electronic parts	Nylon 6 (PA)
Plug connection	ISO 4400/DIN 43650	Dimensions	See drawing
Output		Environmental conditions	
Analog output	4-20 mA	Ambient temperature	-30...+50°C
Alarm output	NA	Refrigerant temperature	-60...+80°C
LED indication	Bar graph (option)	Max pressure	100 bar
Max. load resistance	500 ohm	Protection degree	IP65
Cable specification*		Vibrations	IEC 68-2-6 (4g)
Cable size	3 x 0.34 mm <sup>2</sup>		
Cable glands	PG7 / M8		
Cable resistance	500 Ω/Km		
Approvals			
CE	EN 61000-2		
Configuration			
Type of configuration	Push bottom		

\* Total consumption is sensor consumption plus output and it depends on ambient temperature.

NB: Cable not included.

## Mechanical dimensions

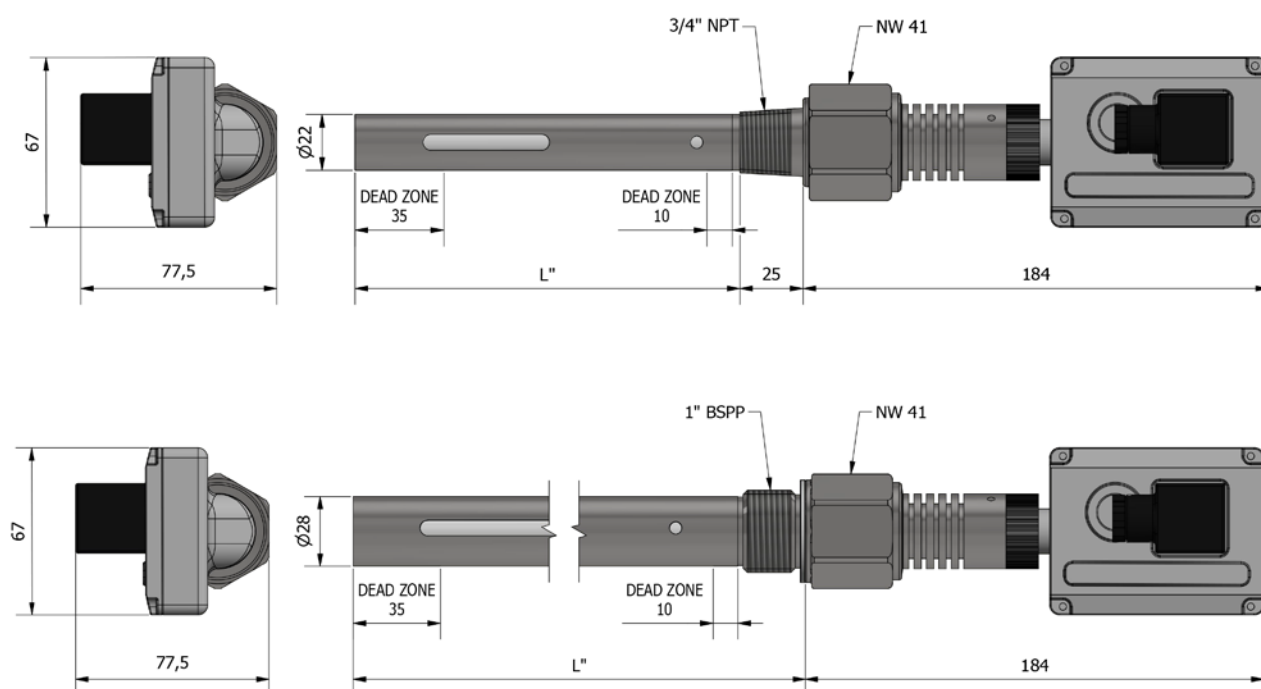

## Ordering codes

Length / thread (G)	Ordering code without Bar graph	Ordering code with Bar graph
280 mm / 1" BSPP	HBLT-A1-2.8	HBLT-A1B-2.8
500 mm / 1" BSPP	HBLT-A1-5	HBLT-A1B-5
800 mm / 1" BSPP	HBLT-A1-8	HBLT-A1B-8
1000 mm / 1" BSPP	HBLT-A1-10	HBLT-A1B-10
1200 mm / 1" BSPP	HBLT-A1-12	HBLT-A1B-12
1500 mm / 1" BSPP	HBLT-A1-15	HBLT-A1B-15
1700 mm / 1" BSPP	HBLT-A1-17	HBLT-A1B-17
2200 mm / 1" BSPP	HBLT-A1-22	HBLT-A1B-22
3000 mm / 1" BSPP	HBLT-A1-30	HBLT-A1B-30
6" / 3/4" NPT	HBLT-A1-6U	HBLT-A1B-6U
8" / 3/4" NPT	HBLT-A1-8U	HBLT-A1B-8U
10" / 3/4" NPT	HBLT-A1-10U	HBLT-A1B-10U
12" / 3/4" NPT	HBLT-A1-12U	HBLT-A1B-12U
15.3" / 3/4" NPT	HBLT-A1-15.3U	HBLT-A1B-15.3U
19.2" / 3/4" NPT	HBLT-A1-19.2U	HBLT-A1B-19.2U
23.1" / 3/4" NPT	HBLT-A1-23.1U	HBLT-A1B-23.1U
30" / 3/4" NPT	HBLT-A1-30U	HBLT-A1B-30U
35" / 3/4" NPT	HBLT-A1-35U	HBLT-A1B-35U
45" / 3/4" NPT	HBLT-A1-45U	HBLT-A1B-45U
55" / 3/4" NPT	HBLT-A1-55U	HBLT-A1B-55U
65" / 3/4" NPT	HBLT-A1-65U	HBLT-A1B-65U
85" / 3/4" NPT	HBLT-A1-85U	HBLT-A1B-85U
105" / 3/4" NPT	HBLT-A1-105U	HBLT-A1B-105U
120" / 3/4" NPT	HBLT-A1-120U	HBLT-A1B-120U



## Spare parts

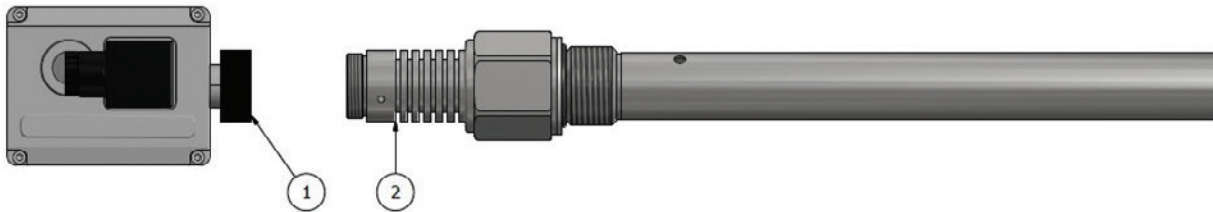

Position	Specification	Type	Thread	Ordering code
1	Electronic parts	Programmable without bar graph		HBLT-A1-EL
		Programmable with bar graph		HBLT-A1B-EL
2	Mechanical parts	For 280 mm length	1" BSPP (G)	HBLT-MEK-2.8
		For 500 mm length	1" BSPP (G)	HBLT-MEK-5
		For 800 mm length	1" BSPP (G)	HBLT-MEK-8
		For 1000 mm length	1" BSPP (G)	HBLT-MEK-10
		For 1200 mm length	1" BSPP (G)	HBLT-MEK-12
		For 1500 mm length	1" BSPP (G)	HBLT-MEK-15
		For 1700 mm length	1" BSPP (G)	HBLT-MEK-17
		For 2200 mm length	1" BSPP (G)	HBLT-MEK-22
		For 3000 mm length	1" BSPP (G)	HBLT-MEK-30
		For 6" length	3/4" NPT	HBLT-MEK-6U
		For 8" length	3/4" NPT	HBLT-MEK-8U
		For 12" length	3/4" NPT	HBLT-MEK-12U
		For 15.3" length	3/4" NPT	HBLT-MEK-15.3U
		For 19.2" length	3/4" NPT	HBLT-MEK-19.2U
		For 23.1" length	3/4" NPT	HBLT-MEK-23.1U
		For 30" length	3/4" NPT	HBLT-MEK-30U
			For 35" length	3/4" NPT
	For 45" length	3/4" NPT	HBLT-MEK-45U	
	For 55" length	3/4" NPT	HBLT-MEK-55U	
	For 65" length	3/4" NPT	HBLT-MEK-65U	
	For 85" length	3/4" NPT	HBLT-MEK-85U	
	For 105" length	3/4" NPT	HBLT-MEK-105U	
	For 120" length	3/4" NPT	HBLT-MEK-120U	

# NH<sub>3</sub> Liquid Level Controller

## Category: HBLC-U-NH3 & HBSLC-U-NH3

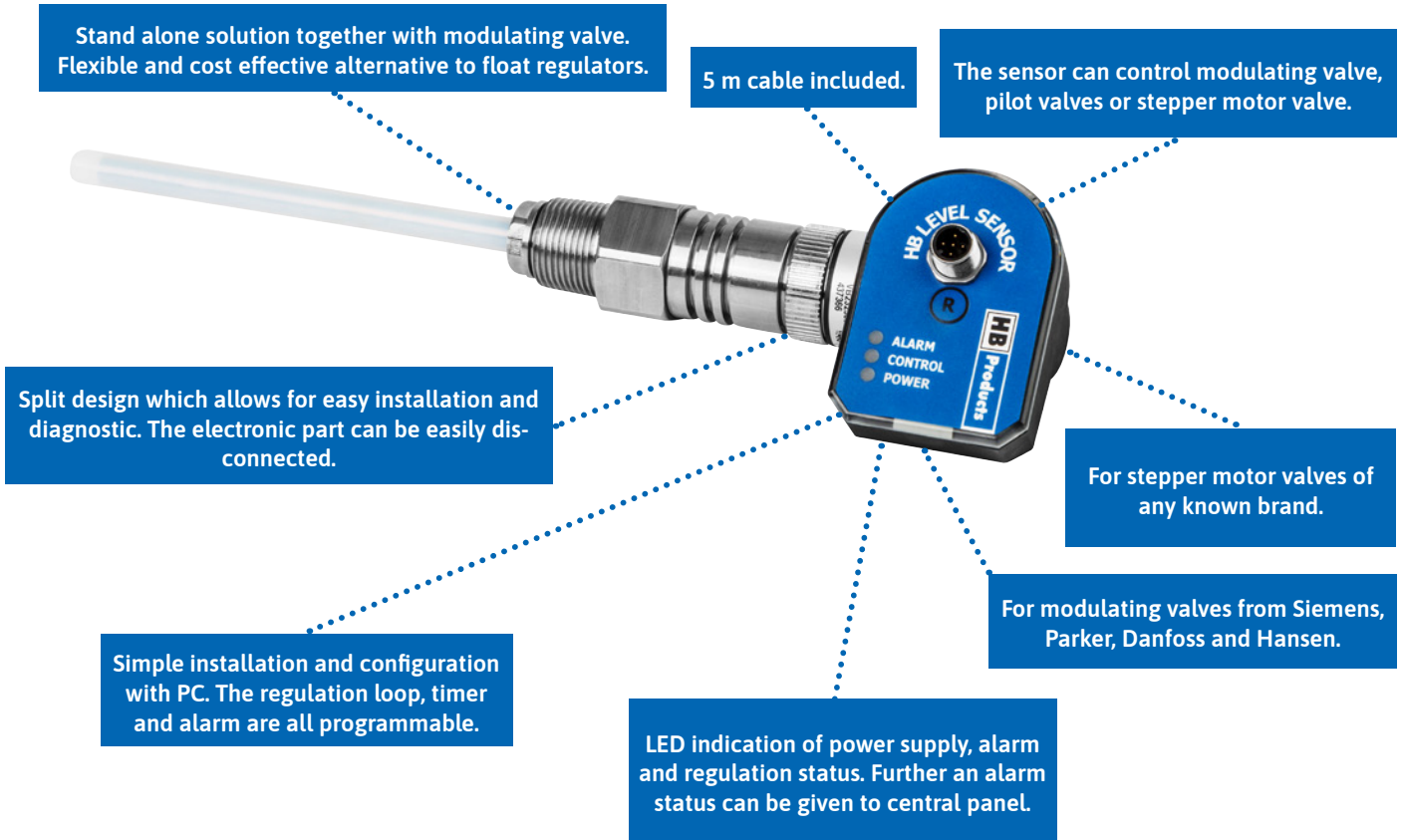

### Functional description:

HBLC-U is an intelligent sensor with a built-in microprocessor. It is designed to control refrigerant levels in both low pressure and high pressure systems. It emits a 4-20 mA signal, which is proportional to the sensor's set range of measurement. Apart from the 4-20 mA signal, the sensor also has a built-in controller. The controller can be set-up with all the parameters necessary for controlling a modulating motor valve or stepper motor. The sensor can be delivered with a cable for direct supply to and control of motor valve or stepper motor valve. The sensor is delivered in a version without integrated cable (named HBLC) and a version with cable for direct control of valves (named HBSLC).

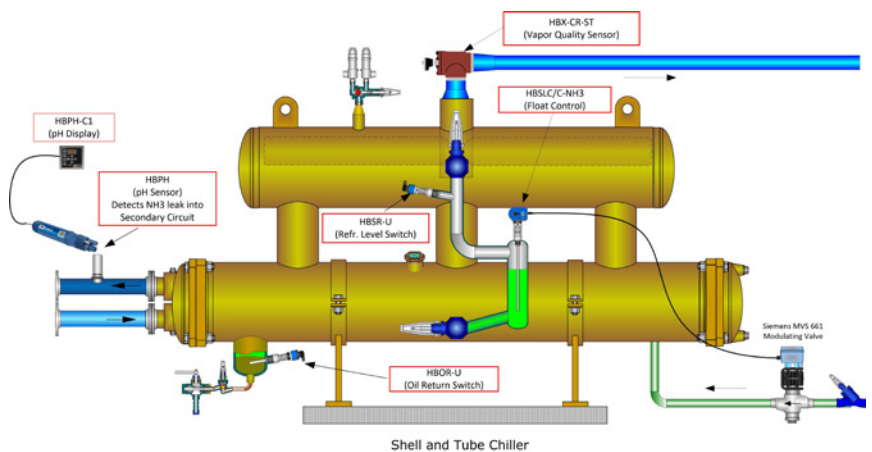

- Available as 2-wire sensor
- Now with ATEX / IECEx certificate (This version is without LED display)

## Technical data - sensor

Power supply		Mechanical specifications	
Voltage	24 V AC/DC + 10%	Thread connection	3/4" NPT/BSPP
Current consumption - sensor only*	250 mA	Material - mechanical parts	AISI 304 / PTFE
Electrical connection	M12, 5 pins - DIN 0627	Material - electronic parts	Nylon 6 (PA)
		Dimensions	See drawing
Output		Environmental conditions	
Analog output	4-20 mA	Ambient temperature	-30...+50°C
Alarm output	Max 1 A (24W)	Refrigerant temperature	-60...+80°C
LED indication	Green, yellow, and red	Max pressure	100 bar
Max. possible resistance	500 ohm	Protection degree	IP65
Cable specification (power supply)		Vibrations	
Cable size	5 m - 3 x 0.25 mm <sup>2</sup>	Accessories	(To be ordered separately)
Cable glands	PG7 / M8	Adapter - 3/4" NPT / 1" BSPP	HBS/ADAP/8/2
Cable resistance	500 Ω/Km	Adapter - 3/4" BSPP / 1" BSPP	HBS/ADAP/8/6
Approvals		Splitter box	
CE	EN 61000-2	Configuration cable	HBxC-USB
Configuration			
Type of configuration	HB Tool		
Tool to be used	HBLC software		

\* Total consumption is sensor consumption plus output and it depends on ambient temperature.

\*\* Power consumption is including consumption on Siemens MVS661 valve

## Technical data - valve regulation

Valve control (Modulating valve)		Valve control (Stepper motor)	
Signal to valve	4-20 mA	Stepper motor steps	25-5000 steps
Valve regulation	P-regulation	Stepper motor speed	2-40 m/s
Cable specification (valve control)		Stepper motor phase current	
Length	3 m (118")	Stepper motor holding current	0-250 mA
Cable size	3 x 0.75 mm <sup>2</sup>		
Cable glands	PG7 / M8		

## Ordering codes

Length	Thread	Without integrated cable	Modulating valve*	Stepper motor**	Pulse width modulation***
160 mm	3/4" NPT	HBLC-U-NH3-1.6-2	HBSLC/C-U-NH3-1.6-2	HBSLC/S-U-NH3-1.6-2	HBSLC/PWM-U-NH3-1.6-2
160 mm	3/4" BSPP	HBLC-U-NH3-1.6-6	HBSLC/C-U-NH3-1.6-6	HBSLC/S-U-NH3-1.6-6	HBSLC/PWM-U-NH3-1.6-6
210 mm	3/4" NPT	HBLC-U-NH3-2.1-2	HBSLC/C-U-NH3-2.1-2	HBSLC/S-U-NH3-2.1-2	HBSLC/PWM-U-NH3-2.1-2
210 mm	3/4" BSPP	HBLC-U-NH3-2.1-6	HBSLC/C-U-NH3-2.1-6	HBSLC/S-U-NH3-2.1-6	HBSLC/PWM-U-NH3-2.1-6
310 mm	3/4" NPT	HBLC-U-NH3-3.1-2	HBSLC/C-U-NH3-3.1-2	HBSLC/S-U-NH3-3.1-2	HBSLC/PWM-U-NH3-3.1-2
310 mm	3/4" BSPP	HBLC-U-NH3-3.1-6	HBSLC/C-U-NH3-3.1-6	HBSLC/S-U-NH3-3.1-6	HBSLC/PWM-U-NH3-3.1-6
400 mm	3/4" NPT	HBLC-U-NH3-4-2	HBSLC/C-U-NH3-4-2	HBSLC/S-U-NH3-4-2	HBSLC/PWM-U-NH3-4-2
400 mm	3/4" BSPP	HBLC-U-NH3-4-6	HBSLC/C-U-NH3-4-6	HBSLC/S-U-NH3-4-6	HBSLC/PWM-U-NH3-4-6
500 mm	3/4" NPT	HBLC-U-NH3-5-2	HBSLC/C-U-NH3-5-2	HBSLC/S-U-NH3-5-2	HBSLC/PWM-U-NH3-5-2
500 mm	3/4" BSPP	HBLC-U-NH3-5-6	HBSLC/C-U-NH3-5-6	HBSLC/S-U-NH3-5-6	HBSLC/PWM-U-NH3-5-6

\*For direct control of a modulating valve such as Siemens MVS661.

\*\*For direct control of a stepper motor valve such as Carel.

\*\*\*For direct control of a pulse width modulation valve such as Danfoss AKVA.

### Mechanical dimensions

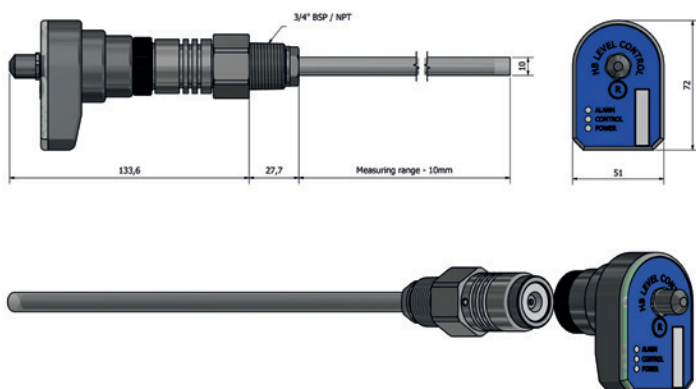

### Spare parts for HBLC-U & HBSLC/C

Position	Specification	Type	Ordering code
1	Mechanical parts	3/4" NPT - 160 mm	HBLC-U-NH3-1.6-2-MEK
		3/4" BSPP - 160 mm	HBLC-U-NH3-1.6-6-MEK
		3/4" NPT - 210 mm	HBLC-U-NH3-2.1-2-MEK
		3/4" BSPP - 210 mm	HBLC-U-NH3-2.1-6-MEK
		3/4" NPT - 310 mm	HBLC-U-NH3-3.1-2-MEK
		3/4" BSPP - 310 mm	HBLC-U-NH3-3.1-6-MEK
		3/4" NPT - 400 mm	HBLC-U-NH3-4-2-MEK
		3/4" BSPP - 400 mm	HBLC-U-NH3-4-6-MEK
		3/4" NPT - 500 mm	HBLC-U-NH3-5-2-MEK
		3/4" BSPP - 500 mm	HBLC-U-NH3-5-6-MEK
2	Electronic parts	Liquid Level Control Sensor for NH3	HBLC-U-NH3-EL
		With cable for control of modulating valve	HBSLC/C/C-NH3-EL
		With cable for control of stepper motor	HBSLC/C/S-NH3-EL
		Special PWM-configuration with cable	HBSLC/C/C-PWM-NH3-EL
		Special PWM-configuration without cable	HBSLC/C/PWM-NH3-EL

\* Spare Parts - Must be calibrated on-site

### Spare parts for HBLC-NH3

Position	Specification	Type	Ordering code
1	Mechanical parts	3/4" NPT - 160 mm	HBLC-NH3-1.6-2-MEK
		3/4" BSPP - 160 mm	HBLC-NH3-1.6-6-MEK
		3/4" NPT - 210 mm	HBLC-NH3-2.1-2-MEK
		3/4" BSPP - 210 mm	HBLC-NH3-2.1-6-MEK
		3/4" NPT - 310 mm	HBLC-NH3-3.1-2-MEK
		3/4" BSPP - 310 mm	HBLC-NH3-3.1-6-MEK
		3/4" NPT - 400 mm	HBLC-NH3-4-2-MEK
		3/4" BSPP - 400 mm	HBLC-NH3-4-6-MEK
		3/4" NPT - 500 mm	HBLC-NH3-5-2-MEK
		3/4" BSPP - 500 mm	HBLC-NH3-5-6-MEK

\* Spare Parts - Must be calibrated on-site

# Level Controller

Category: HBLT-C1 & HBMD-L



HBLT-C1



HBMD-L

## Functional description:

HBLT-C1 is designed for level control in vessels in industrial refrigeration systems. It can be used in connection with the HBLT-A1 and HBLT-Wire analog level sensor or other similar sensors with a 4-20 mA output signal.

### To be used in:

- Pump vessels
- Separators
- Intercoolers
- Economizers
- Condensers
- Receivers

HBMD-L is a display for showing the level value directly like the display on the level sensor. The display can be installed anywhere on the cable between a level sensor and the PLC using M12 cables.

The sensor is supplied with a 5 m M12 extension cable.

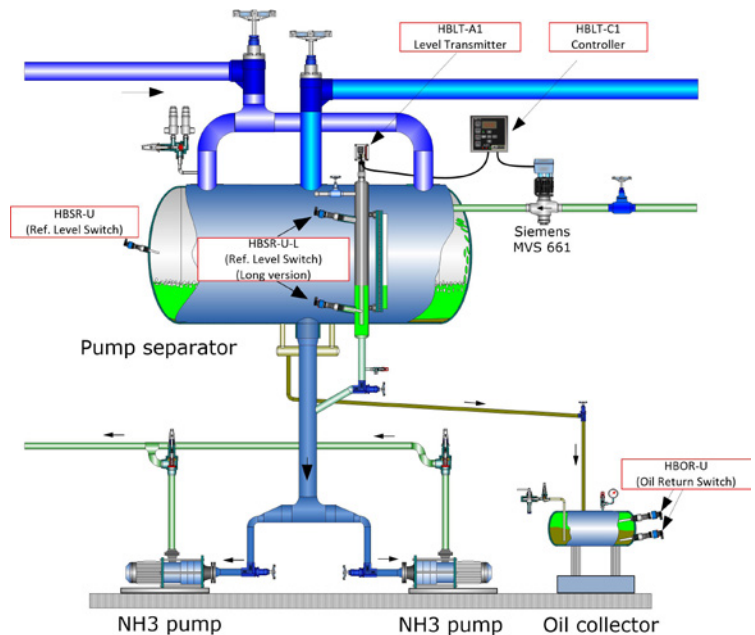

## Technical data

Supply	HBLT-C1	HBLT-C1-ENC	HBMD-L
<b>Voltage</b>	24 V AC/DC ± 10 %	100..240 V AC or 24 V AC/DC	24 V AC/DC ± 10 %
<b>Frequency</b>	50/60 Hz	50/60 Hz	50/60 Hz
<b>Current consumption - sensor only*</b>	Max 40 mA	Max 1.5 A	Max 40 mA
<b>Connection</b>	Screw terminal	Screw terminal	Plug
<b>Wire size</b>	< 2.5 mm <sup>2</sup>	< 2.5 mm <sup>2</sup>	< 2.5 mm <sup>2</sup>
<b>Installation conditions:</b>			
<b>Surrounding temperature</b>	-20...+70°C	-20...+70°C	-40...+70°C
<b>Protection class</b>	IP45	IP65	IP65
<b>Relative humidity</b>	20...80 %	20...80 %	20...80 %
<b>Approvals:</b>			
<b>EMC Emission</b>	EN61000-3-2	EN61000-3-2	EN61000-3-2
<b>EMC Immunity</b>	EN61000-4-2	EN61000-4-2	EN61000-4-2
<b>Mechanical specifications:</b>			
<b>Mounting</b>	In front of panel	In cabinet/casing for mounting on a wall	Wall mounting
<b>External measurement</b>	(96x96x94 (WxHxD))	298x198x182 mm (WxHxD)	100x81x40 mm (WxHxD)
<b>Cut-out measurement</b>	92.8x92.8 mm	N.A.	N/A
<b>Material</b>	Plastic	Plastic	Plastic
<b>Weight</b>	0.2 kg	1.4 kg	0.3 kg
<b>Display:</b>			
<b>Digit's display</b>	3 digits, red	3 digits, red	3 digits, red
<b>Alarm indication</b>	LED (green and red)	LED (green and red)	N/A
<b>Programming</b>	From front	From front	HB Tool
<b>Updating</b>	1 time each second	1 time each second	1 time each second
<b>Input:</b>			
<b>Analog input - sensor</b>	4-20 mA	4-20 mA	4-20 mA
<b>Output:</b>			
<b>Analog output</b>	4-20 mA	4-20 mA	4-20 mA
<b>Load</b>	3A/24 VDC	3A/24 VDC	3A/24 VDC
<b>Relay output</b>	@24VAC/VDC: 3 x 3A @110 V AC: 3 x 5A @220 V AC: 3 x 5A	@24VAC/VDC: 3 x 3A @110 V AC: 3 x 5A @220 V AC: 3 x 5A	@24VAC/VDC: 3 x 3A @110 V AC: 3 x 5A @220 V AC: 3 x 5A

\* Total consumption is sensor consumption plus output and it depends on ambient temperature.

## Ordering codes

Design	Specification
Controller - 24 V AC/DC power supply	HBLT-C1
Controller built in a cabinet and mounted - 100...240 V AC power supply	HBLT-C1-ENC
Multi display - can be used as a local level display - 24 V AC/DC power supply	HBMD-L

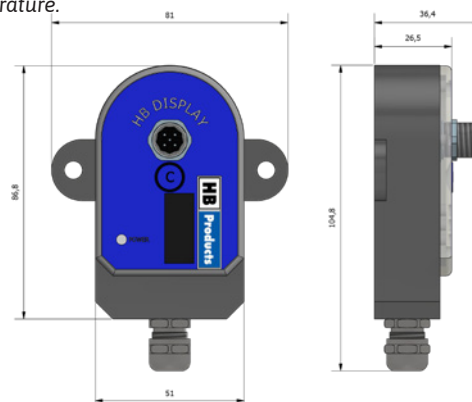

# pH Sensor - Suitable for NH<sub>3</sub>/brine leakage detection

Category: HBPH-MK2-LT

- DIFFERENTIAL 2-WIRE (4-20 mA) pH Sensor

Simple wiring with 2-wire measurement technology.

Measurement range: 0..14 pH - 4...20 mA.

Improved and protected universal flat-faced glass process electrode specially designed for tough applications

Designed with "Semi-flush" design so as to minimize the build-up of dirt on the probe.

Differential measurement technology with replaceable salt bridge.

## Functional description:

HBPH-MK2-LT is a pH sensor designed for the extreme requirements of industrial refrigeration. It is used to measure the pH value of brine in case of an ammonia leak in a heat exchanger. Brine has a pH value of 7, and even for small leaks, the pH will rise to 9-10. The sensor is designed with differential measurement technology that ensures a minimum lifetime of 2 years for the sensor element.

The latest version HBPH-MK2 has an improved and protected universal flat-faced glass process electrode specially designed for tough applications.

The HBPH-MK2-LT -sensor can be used together with our "NH<sub>3</sub>/Brine leakage Display" type HBPH-C1 which is a controller used to calibrate and set up the alarm limit for the HBPH-MK2-LT sensor.

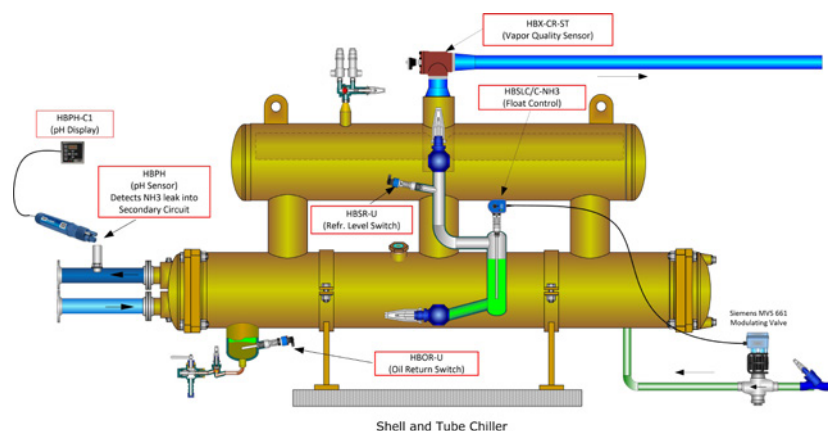

### Technical data

<b>Electrical specifications</b>		<b>Protection degree</b>	IP65
<b>Cable</b>	4.5 m	<b>Flow rate</b>	Max 3.0 m/s
<b>Power supply</b>	20...28 V DC	<b>Vibrations</b>	IEC 68-2-6 (4g)
<b>Output</b>	4...20 mA, not calibrated	<b>Mechanical specifications</b>	
<b>Connection</b>	2-wire	<b>Thread connection</b>	1" NPT
<b>Max load</b>	450 ohm	<b>Material</b>	Ryton, ceramic, titanium, glass, viton
<b>Max cable length</b>	Depends on cable size		
<b>Environmental conditions</b>		<b>Approvals</b>	
<b>Ambient temperature</b>	-15...+50°C (+5...+122°F)	<b>EMC test</b>	EN 61000-2
<b>Liquid temperature</b>	-15...+95°C (+5...+203°F)	<b>Accessories</b>	
<b>Measurement range</b>	0... 14 pH	<b>3-pack salt bridge replacement kit</b>	HBPH-2W-9-MK2-KIT
<b>Resolution</b>	± 0.01 pH	<b>Controller for pH Sensor</b>	HBPH-C1
<b>Max pressure</b>	6.9 bar @ 65°C & 2.75 bar @ 95°C	<b>Controller for pH Sensor in enclosure</b>	HBPH-C1-ENC

### Mechanical dimensions

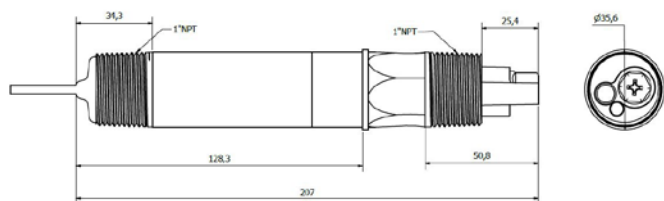

### Ordering codes

Measurement area pH	Thread type	Ordering code
0...14	1" NPT	HBPH-2W-9-MK2-LT

### Parts and Accessories

Position	Specification	Ordering code
1	3-pack salt bridge replacement kit	HBPH-2W-9-MK2-KIT
2	Controller for pH Sensor	HBPH-C1
3	Controller for pH Sensor in enclosure	HBPH-C1-ENC

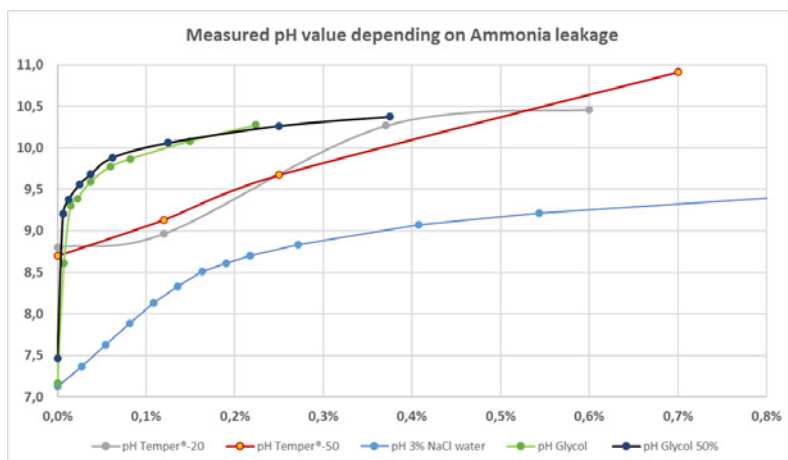

The graf shows how the pH value of different brines are impacted by ammonia leaking into the brine circuit. For more information visit [www.hbproducts.dk](http://www.hbproducts.dk)



# pH Display

Category: HBPH-C1 & HBMD-PH



HBPH-C1



New

HBMD-PH

## Functional description:

HBPH-C1 is a display designed for connection with the HBPH-MK2-LT sensor. In the display, it is possible to calibrate and set up the alarm limit. The display is provided in a version for installation into the front of a panel, as well as a version built into the cabinet. The cabinet version has a 110/240 V supply and can be installed either indoors or outdoors.

HBMD-PH is a display box for showing the pH value directly, when connected with the HBPH sensor. It is possible to do the calibration in the display box and send the pH value on as a linear analog output to a PLC.

The sensor is supplied with a M12 female connector used for connecting the pH sensor and a 5 m M12 supply cable.

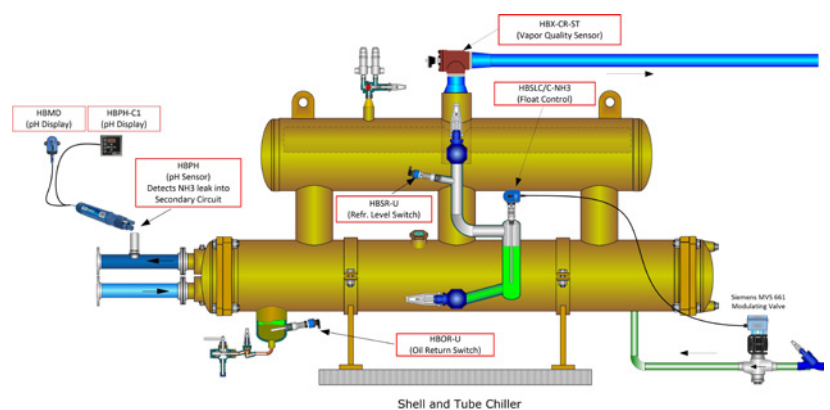

## Technical data

Supply	HBPH-C1	HBPH-C1-ENC	HBMD-PH
Voltage	24 V AC/DC ± 10 %	100..240 V AC or 24 V AC/DC	24 V AC/DC ± 10 %
Frequency	50/60 Hz	50/60 Hz	50/60 Hz
Current consumption - sensor only	Max 40 mA	Max 1.5 A	Max 40 mA
Connection	Screw terminal	Screw terminal	Plug
Wire size	< 2.5 mm <sup>2</sup>	< 2.5 mm <sup>2</sup>	< 2.5 mm <sup>2</sup>
<b>Installation conditions:</b>			
Surrounding temperature	-20...+70°C	-20...+70°C	-40...+70°C
Protection class	IP45	IP65	IP65
Relative humidity	20...80 %	20...80 %	20...80 %
<b>Approvals:</b>			
EMC Emission	EN61000-3-2	EN61000-3-2	EN61000-3-2
EMC Immunity	EN61000-4-2	EN61000-4-2	EN61000-4-2
<b>Mechanical specifications:</b>			
Mounting	In front of panel	In a cabinet/box for mounting on a wall	Wall mounting
External measurement	96x96x94 mm (BxHxD)	298x198x182 mm (BxHxD)	100x81x40 mm (WxHxD)
Cut-out measurement	92.8x92.8 mm	N.A.	N/A
Material	Plastic	Plastic	Plastic
Weight	0.2 kg	1.4 kg	0.3 kg
<b>Display:</b>			
Digit's display	3 digits, red	3 digits, red	3 digits, red
Alarm indication	LED (green and red)	LED (green and red)	N/A
Programming	From front	From front	HB Tool
Updating	1 time each second	1 time each second	1 time each second
<b>Input:</b>			
Analog input - sensor	4-20 mA	4-20 mA	4-20 mA
<b>Output:</b>			
Analog output	4-20 mA	4-20 mA	4-20 mA
Load	3A/24 VDC	3A/24 VDC	3A/24 VDC
Relay output	@24VAC/VDC: 3 x 3A @110 V AC: 3 x 5A @220 V AC: 3 x 5A	@24VAC/VDC: 3 x 3A @110 V AC: 3 x 5A @220 V AC: 3 x 5A	@24VAC/VDC: 3 x 3A @110 V AC: 3 x 5A @220 V AC: 3 x 5A

## Ordering codes

Design	Specification
Controller - 24 V AC/DC power supply	HBPH-C1
Controller built in a cabinet and mounted - 100...240 V AC power supply	HBPH-C1-ENC
Multi-display - can be used as a local level display - 24 V AC/DC power supply	HBMD-PH

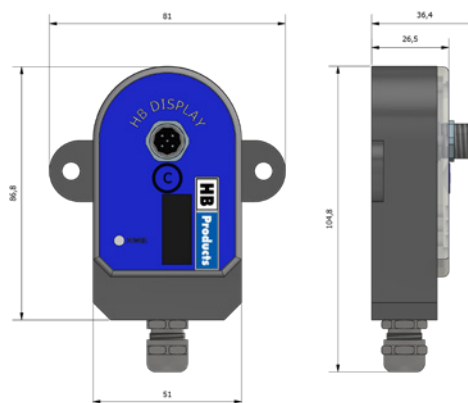

# NH<sub>3</sub> Gas Leakage Alarm/Sensor

Category: HBGS

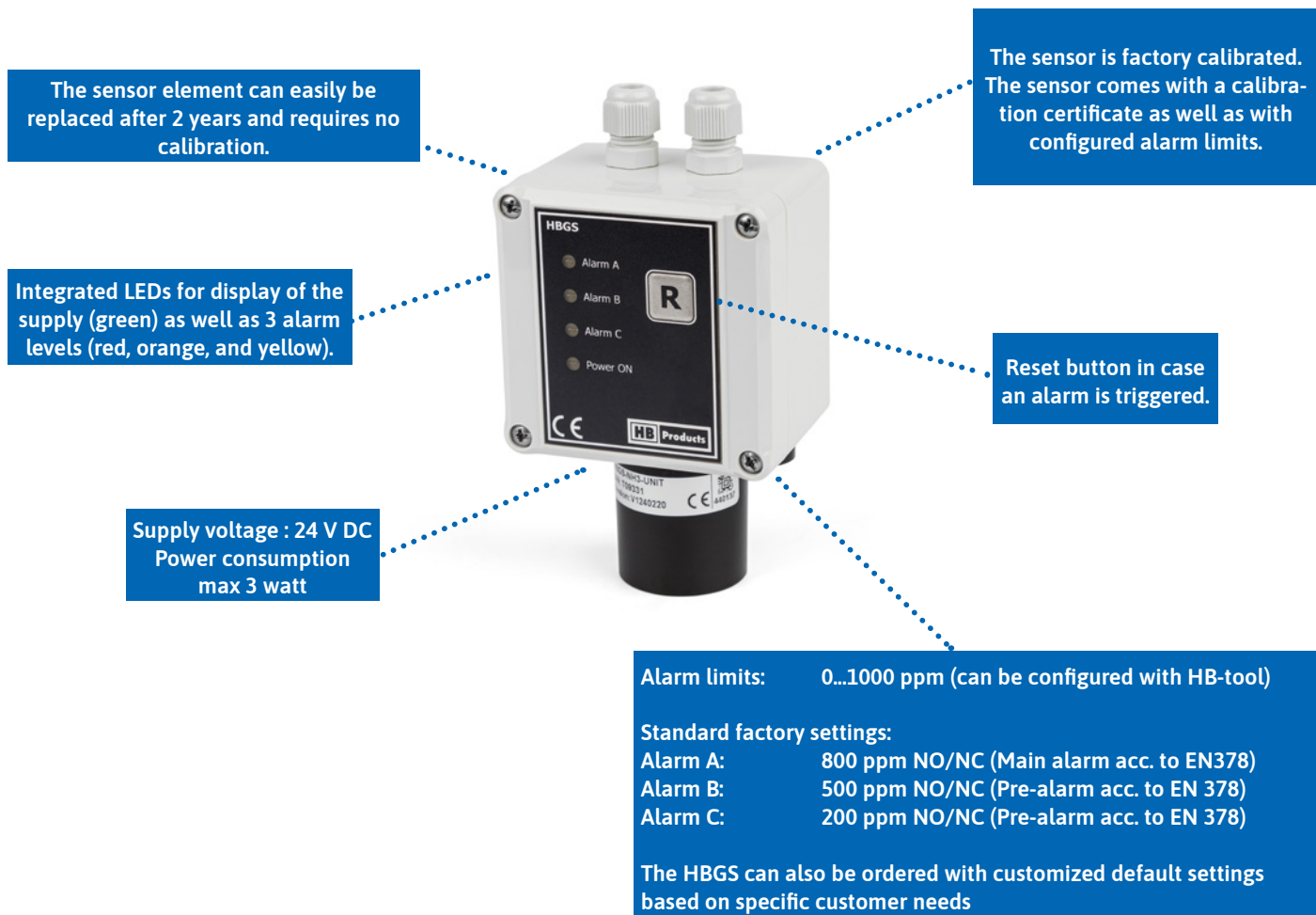

## Functional description:

HBGS fulfills the requirements for gas leakage measurement in accordance with F-GAS regulation EU/517/2014. HBGS detects CO<sub>2</sub> (R744) in a range of 0...10000 ppm. It is an independent unit that must be supplied with 24 V DC. It has 3 built-in digital alarm output and 1 analog 4... 20 mA output. The sensor can be set up using a PC with the HB Configuration Tool.

The CO<sub>2</sub> sensor version has a lifetime of more than 5 years. Both sensor elements can easily be replaced and does not require a new calibration. On the front, you can find 4 integrated LEDs for display of the supply (green) as well as 3 alarm levels (red, orange, and yellow). Similarly, there is a reset button in case an alarm is

triggered. The sensor is factory calibrated. Verification during the lifetime can be done with high gas concentrations. The sensor is optimized for use in areas where cleaning solvents are used. Built-in heating element ensures low ambient temperatures down to -30 ° C. The sensor comes with a calibration certificate as well as with preconfigured alarm limits.

### Technical data

Electrical connection		Mechanical specifications	
Measuring accuracy	+/-10%	Cabinet size	82x59x126mm
Connection	Screw terminals		
Cable connection	2xPG7	Material	Plastic
Supply voltage	24 V DC – Power consumption max 3watt	Mounting	On walls with screws
Analog output	4...20 mA	Alarm	Can be configured with HB-tool
Max load:	500 ohm	Alarm limits	0 to 1000 ppm
Digital output - relay:	3 x SPDT, 0.5A	Alarm A	800 ppm NO/NC (Main alarm acc. to EN378)
		Alarm B	500 ppm NO/NC (Pre-alarm acc. to EN 378)
		Alarm C	200 ppm NO/NC (Pre-alarm acc. to EN 378)
Installation conditions		Approvals	
Ambient temperature:	-30...+50°C	EMC Emission	EN 61000-3-2
Protection degree	IP20, box IP65	EMC Immunity	EN 61000-4-2
Vibrations	IEC 68-2-6 (4g)		

### Mechanical dimensions

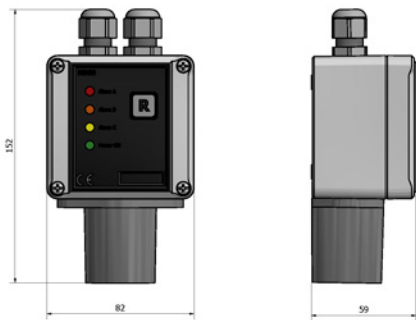

### Ordering codes

House design	Gas	Measuring area	Ordering code
Front	NH3 (R717)	0... 1000 ppm	HBGS-NH3



HBGS-NH<sub>3</sub>-ServiceKit

### Spare parts

Accessories for test and calibration	Gas	Ordering code
Part no. Sensor Part	NH3 (R717)	HBGS-NH3-Unit
Part no. Service kit	NH3 (R717)	HBGS-NH3-ServiceKit
Part no. Siren/flash light	NH3 (R717)	Sounder Beacon



# Carbon Dioxide - CO<sub>2</sub>

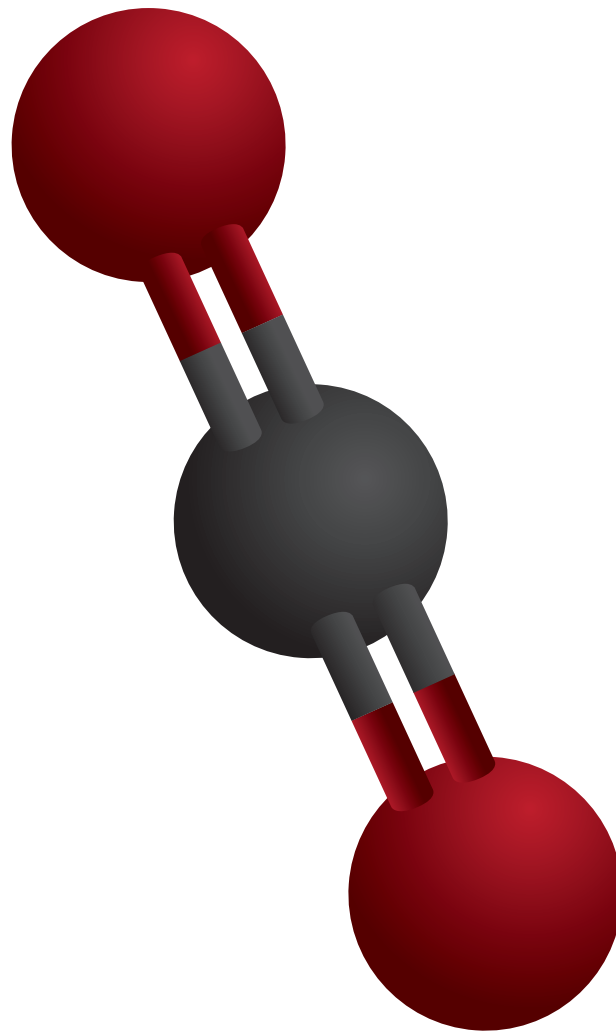

# Two-stage Transcritical CO<sub>2</sub> Plant - Principle

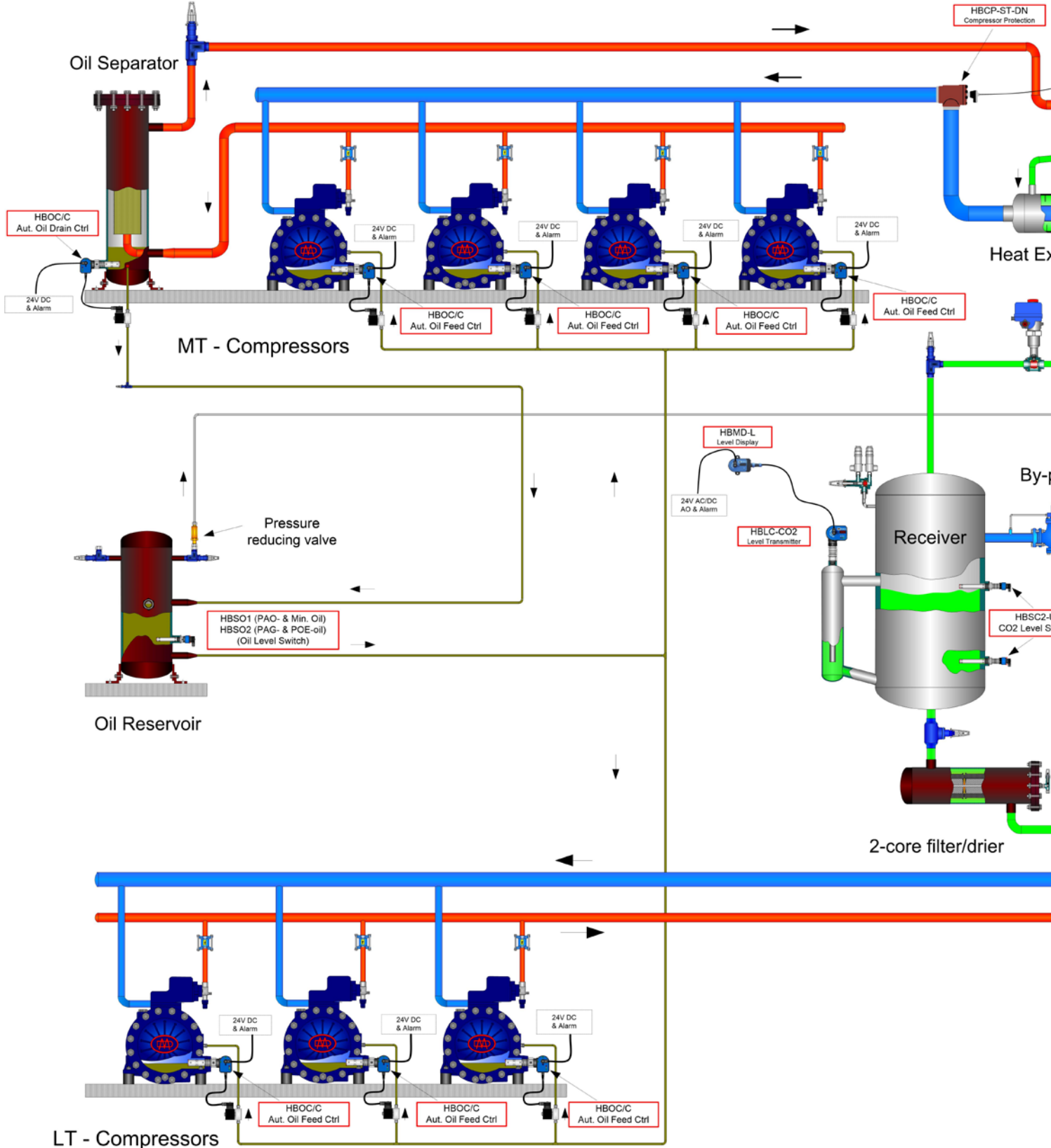

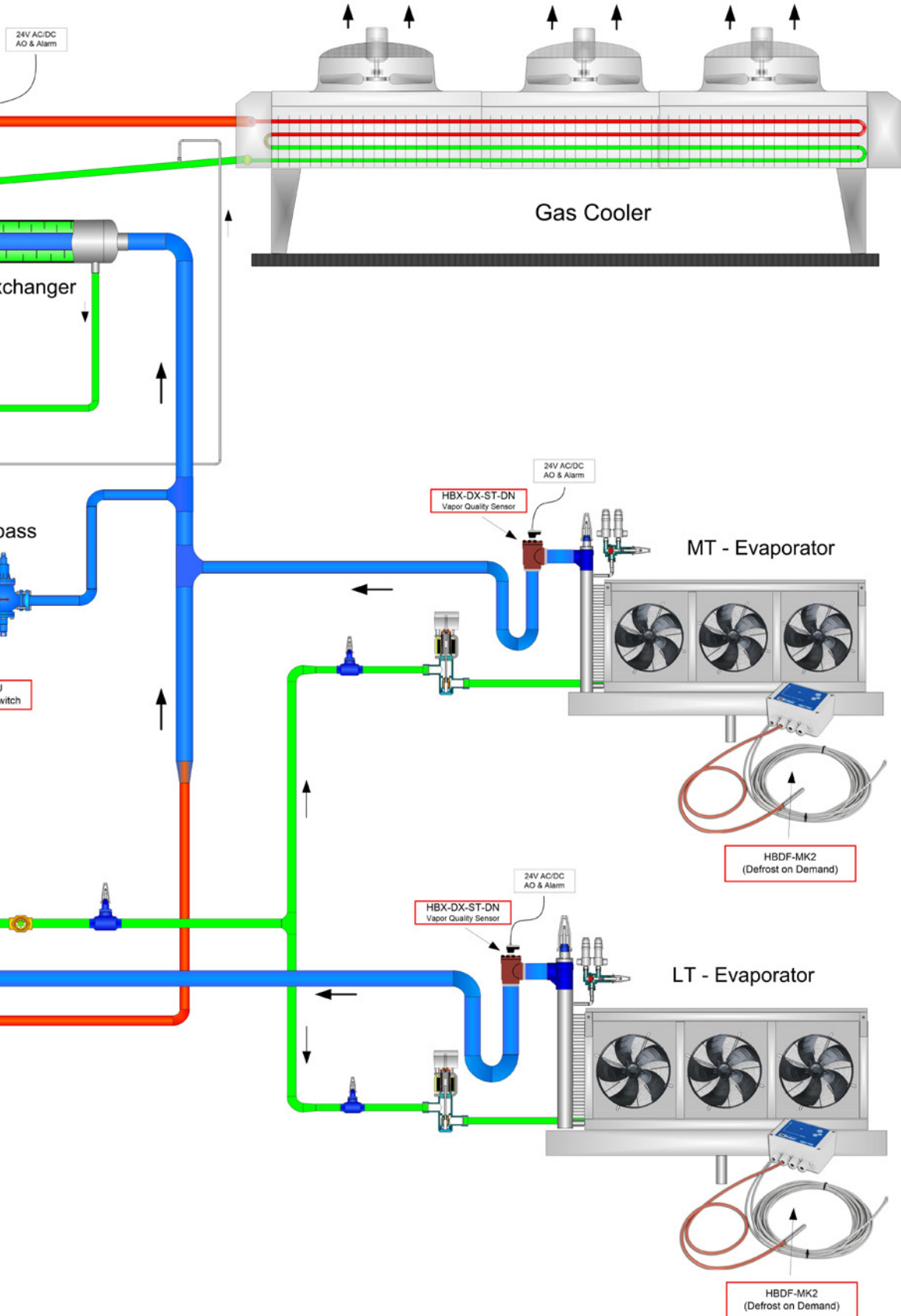

# plant - principle







# Switches, Sensors and Controls for CO<sub>2</sub> Refrigeration Installations

## ON/OFF Switches

CO <sub>2</sub> liquid	<b>Function:</b> CO <sub>2</sub> Liquid Level Switch - 24 V AC/DC <b>Application:</b> Level switch in vessels <b>Refrigerant Temperature:</b> -55...+30°C <b>Supply:</b> 24 V AC/DC <b>Output:</b> PNP/NPN - 1A		<b>Page 81</b>
	<b>Function:</b> CO <sub>2</sub> Liquid Level Switch - 90...240 V AC <b>Application:</b> Level switch in vessels <b>Refrigerant Temperature:</b> -55...+30°C <b>Supply:</b> 90...240 V AC <b>Output:</b> Solid state relay		<b>Page 84</b>
	<b>Function:</b> CO <sub>2</sub> Liquid Level Switch - Low Temperature <b>Application:</b> CO <sub>2</sub> switch - Low temperature <b>Refrigerant Temperature:</b> -55...+30°C <b>Supply:</b> 24 V DC <b>Output:</b> Solid state relay		<b>Page 86</b>

## Sensors and Controllers

CO <sub>2</sub> liquid	<b>Function:</b> Liquid Level Sensor - Flex (HFC / HFO / CO <sub>2</sub> ) <b>Applications:</b> Level measurement in standpipes <b>Refrigerant Temperature:</b> -60...+60°C <b>Supply:</b> 24 V AC/DC <b>Output:</b> 4...20 mA/PNP - 1A		<b>Page 88</b>
	<b>Function:</b> CO <sub>2</sub> Liquid Level Sensor <b>Applications:</b> Chillers, evaporators and condensers <b>Refrigerant Temperature:</b> -55...+30°C <b>Supply:</b> 24 V AC/DC <b>Output:</b> 4...20 mA / PNP-1A		<b>Page 91</b>
	<b>Function:</b> Level Controller <b>Applications:</b> Level control on e.g. pump separators <b>Supply:</b> 24 V AC/DC / 100-240 V AC <b>Output:</b> 4...20 mA / 3x solid state relay - 3/5 A		<b>Page 94</b>
	<b>Function:</b> Gas Leakage Alarm/Sensor <b>Applications:</b> Safety switch/sensor for gas leakage detection <b>Supply:</b> 24 V DC <b>Output:</b> 4...20 mA / 3 x SPDT, 0,5A		<b>Page 96</b>



# CO<sub>2</sub> Liquid Level Switch - 24 V AC/DC

Category: HBSC2-U

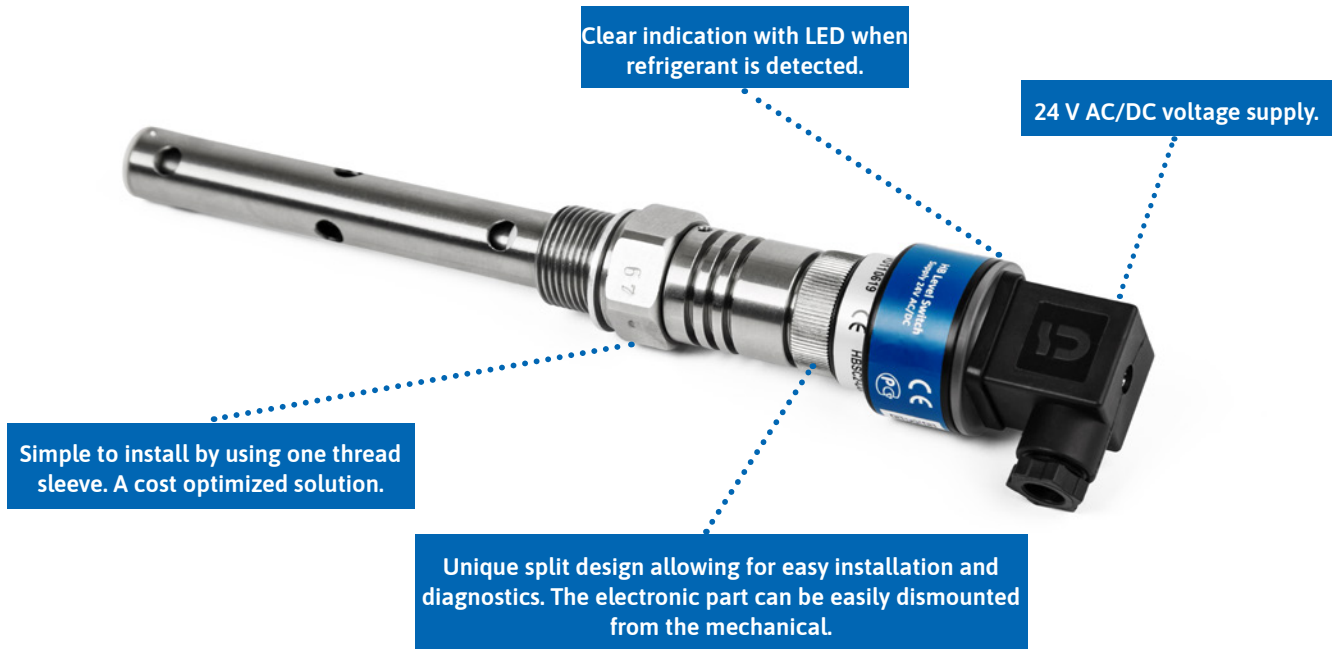

- Available as 2-wire sensor
- Now with ATEX / IECEx certificate (This version is without LED display)

## Functional description:

HBSC2-U is a level switch for detecting liquid CO<sub>2</sub> in refrigeration systems. Typically, it is installed in/on the receiver, but it is also suited for installation in other locations where a level indication is needed. The sensor's measurement principle makes it unique for these purposes, since the properties of the measurement principle as well as its special construction allows it to withstand high pressure and low refrigerant temperatures. The sensor is suited for use on transcritical CO<sub>2</sub> refrigeration systems.

- For almost 20 years switches from HB Products have been supplied worldwide.
- More than 10.000 switches are produced every year.
- We deliver switches as OEM products to the leading suppliers of industrial refrigeration equipment.

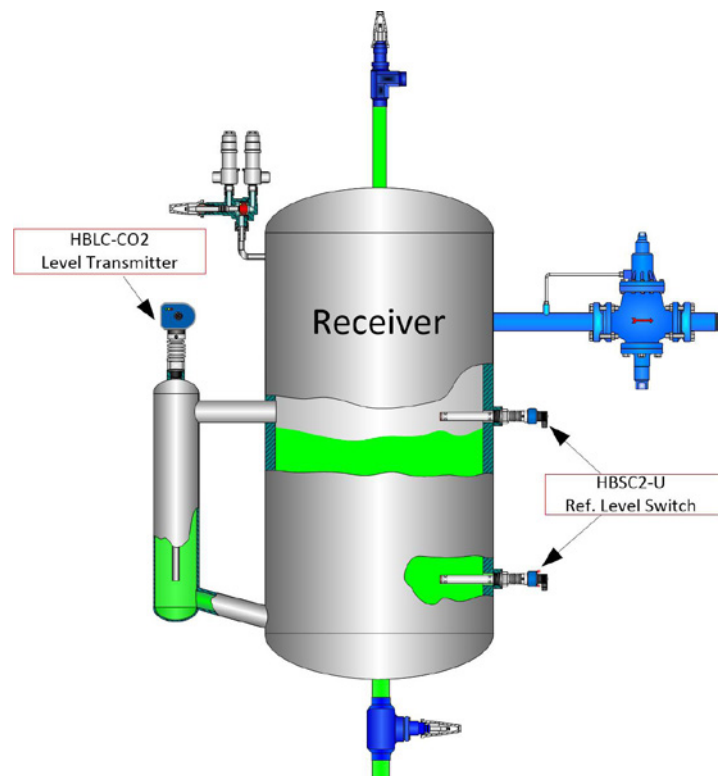

## Technical data

Power supply		Mechanical specifications	
Voltage	24 V AC/DC + 10%	Thread connection	3/4" NPT / BSPP
Max. current output	Max 50 mA	Material – mechanical parts	AISI 304 / PTFE
Current consumption - sensor only*	200 mA	Material – electronic parts	Nylon 6 (PA)
Plug connection	ISO 4400/DIN 43650	Dimensions	210x52x40
Output		Environmental conditions	
Output type	PNP or NPN - 50 mA	Ambient temperature	-30...+50°C
Output function	NC or NO	Refrigerant temperature*	-55...+30°C
LED indication	4 x red	Max pressure	150 bar
Cable specification**		Protection degree	IP65**
Cable size	3 x 0.34 mm <sup>2</sup>	Vibrations	IEC 68-2-6 (4g)
Cable glands	PG7 / M8		
Cable resistance	500 Ω/Km		
Approvals			
CE	EN 61000-2		

\* Total consumption is sensor consumption plus output and it depends on ambient temperature.

\*\* Cable not included.

## Mechanical dimensions

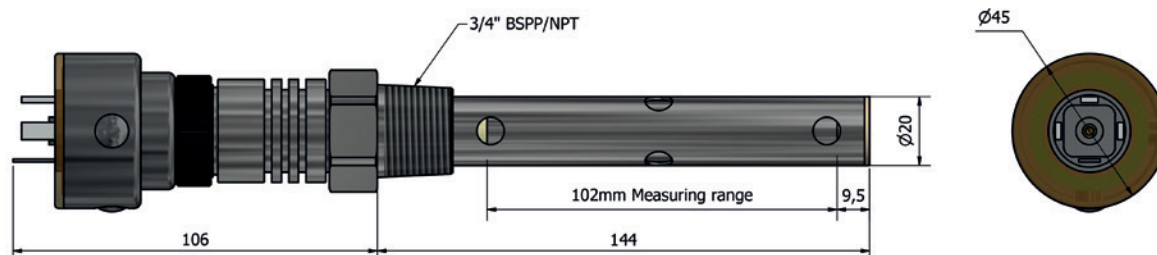

## Ordering codes

Output	Thread type	Ordering code
PNP / NO	3/4" NPT	HBSC2-U-PNP/NO-2
PNP / NC	3/4" NPT	HBSC2-U-PNP/NC-2
PNP / NO	3/4" BSPT	HBSC2-U-PNP/NO-4
PNP / NC	3/4" BSPT	HBSC2-U-PNP/NC-4
PNP / NO	3/4" BSPP	HBSC2-U-PNP/NO-6
PNP / NC	3/4" BSPP	HBSC2-U-PNP/NC-6
NPN / NO	3/4" NPT	HBSC2-U-NPN/NO-2
NPN / NC	3/4" NPT	HBSC2-U-NPN/NC-2
NPN / NO	3/4" BSPT	HBSC2-U-NPN/NO-4
NPN / NC	3/4" BSPT	HBSC2-U-NPN/NC-4
NPN / NO	3/4" BSPP	HBSC2-U-NPN/NO-6
NPN / NC	3/4" BSPP	HBSC2-U-NPN/NC-6

4 x red LED's indicate liquid detection.  
 4 x green LED's flashing indicate no detection, but sensor is active.  
 4 x red flashing LED's indicate no connection to mechanical unit.

**Switch contact output:**

**NC:** Relay contact is normally closed (current can flow) and opens when liquid is detected.

**NO:** Relay contact is normally open (no current flow) and closes when liquid is detected.

### Spare parts for HBSC2-U

Position	Specification	Type	Ordering code
1	Electronic parts	NPN/NO	HBSC2-U-EL/NPN/NO
		NPN/NC	HBSC2-U-EL/NPN/NC
		PNP/NO	HBSC2-U-EL/PNP/NO
		PNP/NC	HBSC2-U-EL/PNP/NC
2	Mechanical parts	¾" NPT	HBSC2-U-MEK-2
		¾" BSPT	HBSC2-U-MEK-4
		¾" BSPP	HBSC2-U-MEK-6

### Spare parts for HBSC2

Position	Specification	Type	Ordering code
1	Electronic parts	NPN/NO	HBSC2-EL/NPN/NO
		NPN/NC	HBSC2-EL/NPN/NC
		PNP/NO	HBSC2-EL/PNP/NO
		PNP/NC	HBSC2-EL/PNP/NC

# CO<sub>2</sub> Liquid Level Switch - 90...240 V AC

Category: HBSC2-U-SSR2

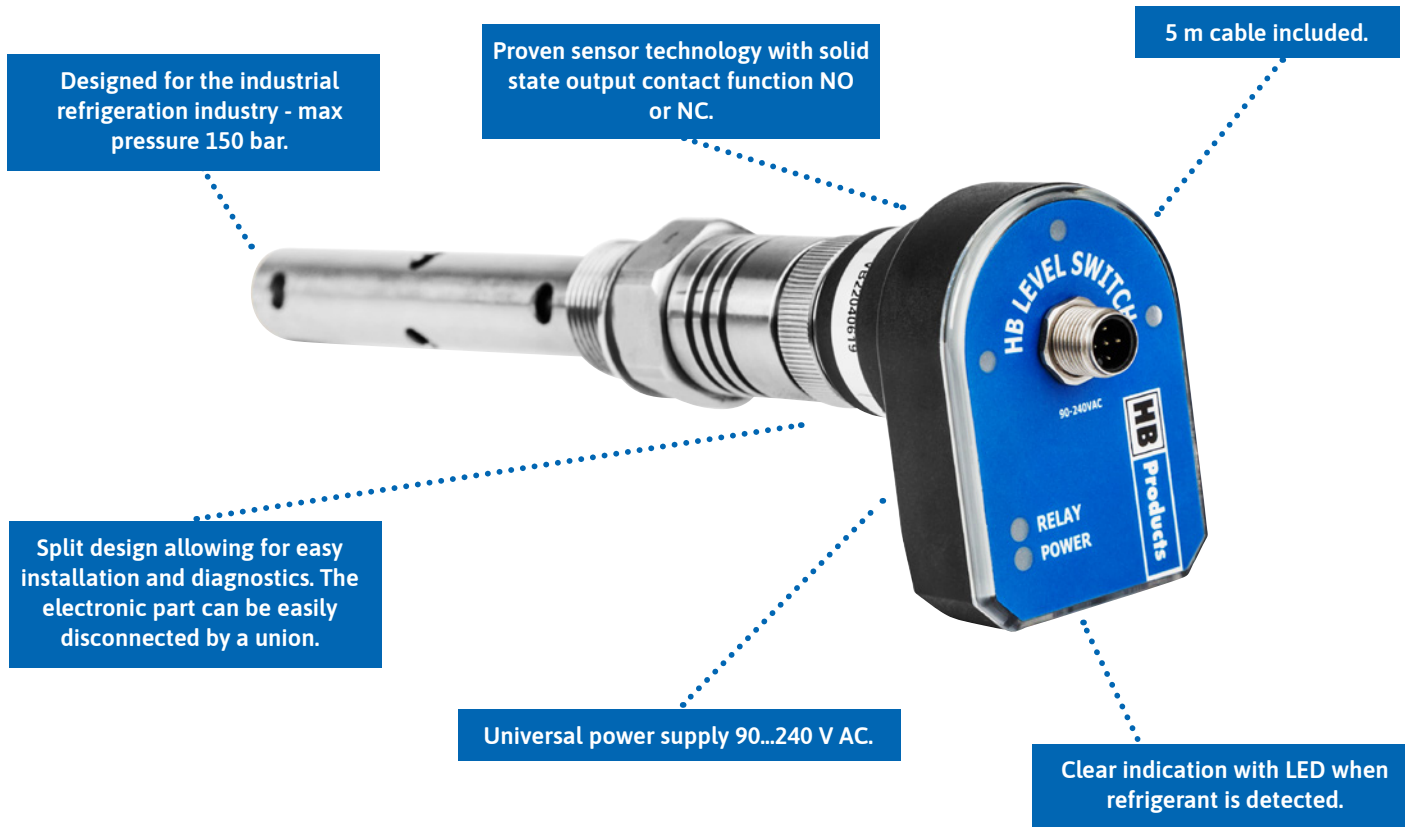

## Functional description:

HBSC2-U-SSR2 is a level switch for detecting liquid CO<sub>2</sub> in refrigeration systems. Typically, it is installed in/on the receiver, but it is also suited for installation in other locations where a level indication is needed. The sensor's measurement principle makes it unique for these purposes, since the properties of the measurement principle as well as its special construction allows it to withstand high pressure and low refrigerant temperatures. The sensor is suited for use on transcritical CO<sub>2</sub> refrigeration systems.

The switch has a built-in local power supply for direct use on grid supply 90...240 V AC. A solid state relay can also operate a valve directly.

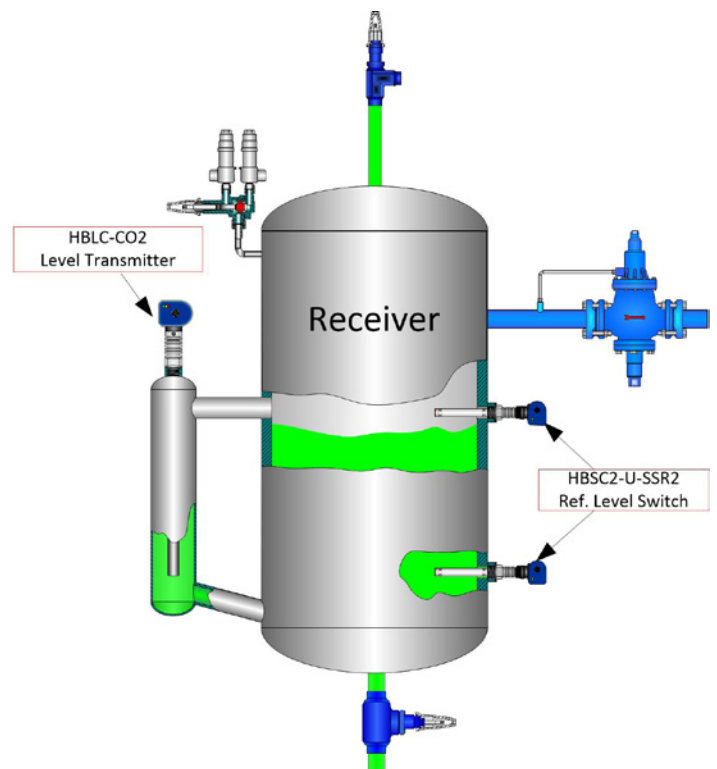

## Technical data

Power supply		Mechanical specifications	
Voltage	90...240 V AC	Thread connection	3/4" NPT / BSPP
Current consumption - sensor only	< 10 mA	Material – mechanical parts	AISI 304 / PTFE
Max. current output	Max 50 mA	Material – electronic parts	Nylon 6 (PA)
Plug connection	M12 - DIN 0627	Dimensions	251 x 51 x 72 mm
Output		Environmental conditions	
Output type	Solid state relay - 40 W	Ambient temperature	-30...+50°C
Output function	NC or NO	Refrigerant temperature	-55...+30°C
LED indication	Level indication: 3 x LED (green) Relay-on activation: 1 x Led (yellow) Power supply: 1 x LED (green)	Max pressure	150 bar
Cable specification (power supply)		Protection degree	IP65
Cable size	3 x 0,34 mm <sup>2</sup>	Vibrations	IEC 68-2-6 (4g)
Cable glands	PG7 / M8		
Cable resistance	500 Ω/Km		
Approvals			
CE	EN 61000-2		

\*For outdoor and low temperature application use low temperature type with built-in heater.

## Mechanical dimensions

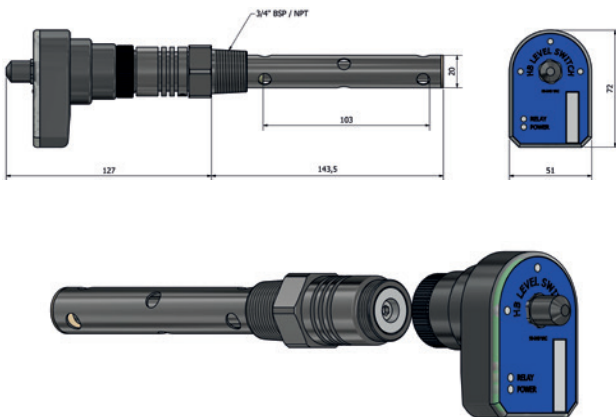

## Ordering codes

Output	Thread type	Ordering code
Solid state relay - NO	3/4" NPT	HBSC2-U-SSR2/NO-2
Solid state relay - NO	3/4" BSPP	HBSC2-U-SSR2/NO-6
Solid state relay - NC	3/4" NPT	HBSC2-U-SSR2/NC-2
Solid state relay - NC	3/4" BSPP	HBSC2-U-SSR2/NC-6

## Spare parts

Position	Specification	Type	Ordering code
1	Electronic parts	NO	HBSC2-U-SSR2/NO-EL
		NC	HBSC2-U-SSR2/NC-EL
2	Mechanical parts	3/4" NPT	HBSC2-U-MEK-2
		3/4" BSPP	HBSC2-U-MEK-6

# CO<sub>2</sub> Liquid Level Switch - Low Temperature

Category: HBSC2-SSR-1/IP

Designed for the industrial refrigeration industry - max pressure up to 150 bar.

Clear LED indication at level detection.

Split design makes it possible to mount and perform diagnostics without emptying the tanks for refrigerant.

5 m cable included.



Reliable design with electronic solid state output and contact function NO or NC.

## Functional description

HBSC2-SSR-1/IP refrigerant switch with built-in heater to protect against condensation at low temperatures. The switch is suited for use in freezers and for outdoor applications. It will typically be used for control of refrigerant liquid supply to separators. It is also used to control drainage of the liquid refrigerant during hot gas defrost.

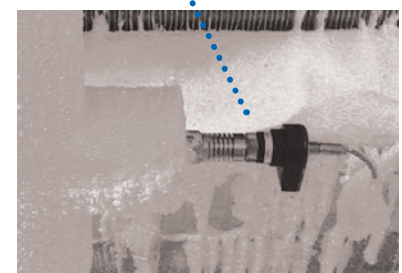
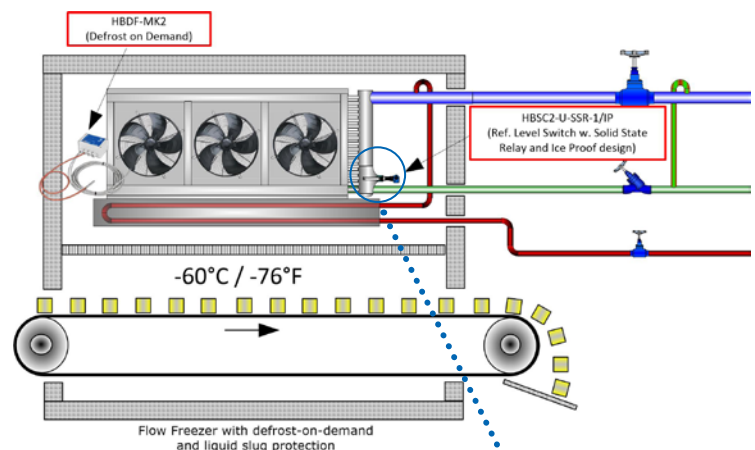

## Technical data

Power supply		Mechanical specifications	
Voltage	24 V DC $\pm$ 10%	Thread connection	3/4" NPT
		Material – mechanical parts	AISI 304 / PTFE
Current consumption - sensor only*	Max 600 mA	Material – electronic parts	PA46-GF30
Plug connection	M12, 5 pins - DIN 0627	Dimensions	254 x 51 x 72 mm
Output		Environmental conditions	
Output type	1A (24V DC)	Ambient temperature	-60...+50°C
Output function	NC or NO	Refrigerant temperature	-55...+30°C
LED indication	Green, yellow, and red	Max pressure	150 bar
Cable specification (power supply)		Protection degree	IP66
Cable size	5m - 4 x 0,34 mm <sup>2</sup>	Vibrations	IEC 68-2-6 (4g)
Cable glands	PG7 / M8		
Cable resistance	500 $\Omega$ /Km		
Approvals			
CE	EN 61000-2		

\* Total consumption is sensor consumption plus output and it depends on ambient temperature.

## Mechanical dimensions

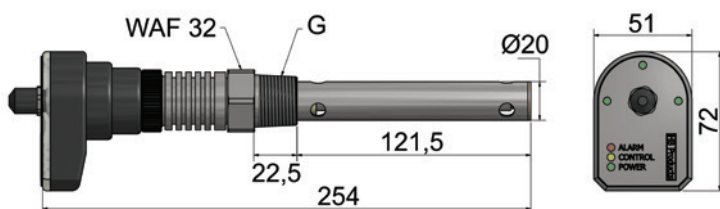

## Ordering codes

Output	Thread type (G)	Ordering code
NC	3/4" NPT	HBSC2-SSR-1/IP-2-NC
NO	3/4" NPT	HBSC2-SSR-1/IP-2-NO
NC	3/4" BSPP	HBSC2-SSR-1/IP-6-NC
NO	3/4" BSPP	HBSC2-SSR-1/IP-6-NO
NC	1" BSPP	HBSC2-SSR-1/IP-8-NC
NO	1" BSPP	HBSC2-SSR-1/IP-8-NO

## Spare parts

Position	Specification	Type	Ordering code
1	Electronic parts	PC-programmable / NO	HBSC2-SSR-1/IP-EL-NO
		PC-programmable / NC	HBSC2-SSR-1/IP-EL-NC
2	Mechanical parts	3/4" NPT thread	HBSC2-SSR-1-MEK-2
		3/4" BSPP thread	HBSC2-SSR-1-MEK-6
		1" BSPP thread	HBSC2-SSR-1-MEK-8

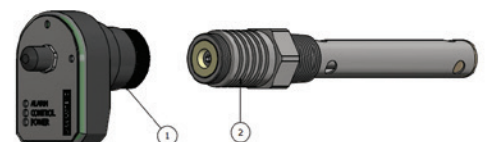

# Liquid Level Sensor - Flex

Category: HBLT-Flex & HBSLT-Flex- HFC / HFO / CO<sub>2</sub>

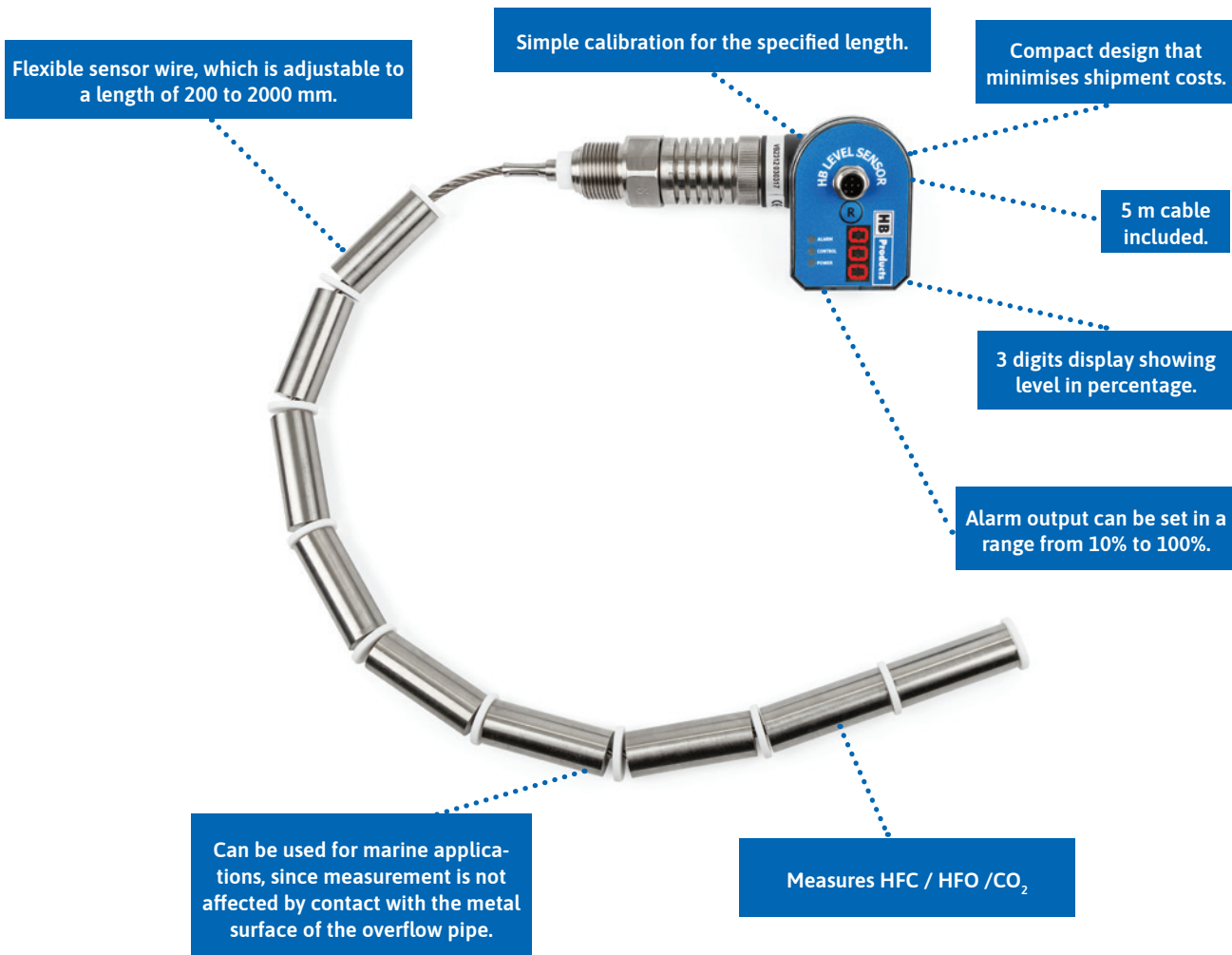

## Functional description:

HBLT-flex is a capacitive sensor for level measurement of HFC/HFO/CO<sub>2</sub> refrigerant in industrial refrigeration systems. The sensor has an output signal of 4-20 mA, which is proportional with 0 and 100%. Its output signal is 4 mA for an empty container and 20 mA for a full container. HBLT-flex can be adjusted in length to the current application. The sensor element consists of a 4 mm steel wire and 5 cm aluminum weights. The HBLT-FLEX sensor can be delivered in lengths of 200 - 2000 mm and can be used in connection with the HBLT-C1 controller for controlling pumps, etc., or it can be configured to directly control a valve without the need for another controller.

The sensor is delivered in a version without integrated cable (named HBLT-Flex) and a version with cable for direct control of valves (named HBSLT-Flex).

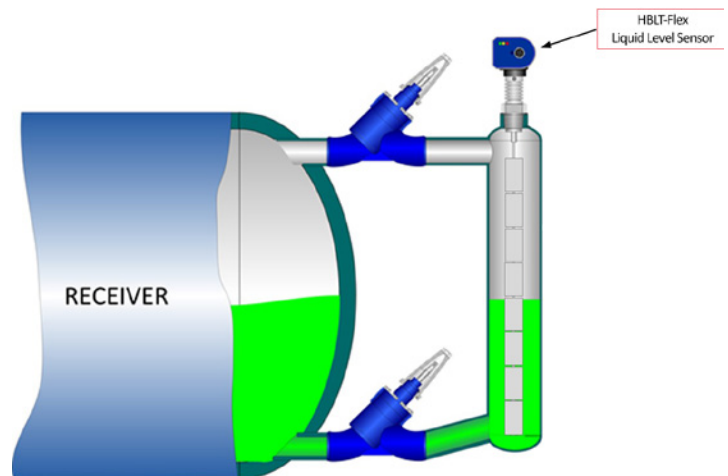



## Technical data

Power supply		Mechanical specifications	
Voltage	24 V AC/DC + 10%	Thread connection	3/4" NPT/BSPP
Current consumption - sensor only*	Max 30 mA	Material - mechanical parts	AISI 304 / PTFE
Plug connection	ISO 4400/DIN 43650	Material - electronic parts	Nylon 6 (PA)
<b>Output</b>		Dimensions	See drawing
Analog output	4-20 mA	<b>Environmental conditions</b>	
Alarm output	PNP, 1 A	Ambient temperature	-30...+50°C
LED indication	3 digits display	Refrigerant temperature	-60...+60°C
Max. possible resistance	500 ohm	Max pressure	100 bar
<b>Cable specification (power supply)</b>		Protection degree	IP65
Cable size	5 m - 3 x 0.25 mm <sup>2</sup>	Vibrations	IEC 68-2-6 (4g)
Cable glands	PG7 / M8	<b>Accessories (To be ordered separately)</b>	
Cable resistance	500 Ω/Km	Adapter - 3/4" NPT / 1" BSPP	HBS/ADAP/8/2
<b>Approvals</b>		Adapter - 3/4" BSPP / 1" BSPP	HBS/ADAP/8/6
CE	EN 61000-2	Splitterbox	HBxC-Splitbox
EAC Regulation of Conformity		Adapter cable	HBxC-M12/DIN
<b>Configuration</b>			
Type of configuration	HB Tool		
Tool to be used	HBLT-Wire software		

\* Total consumption is sensor consumption plus output and it depends on ambient temperature.

## Mechanical dimensions

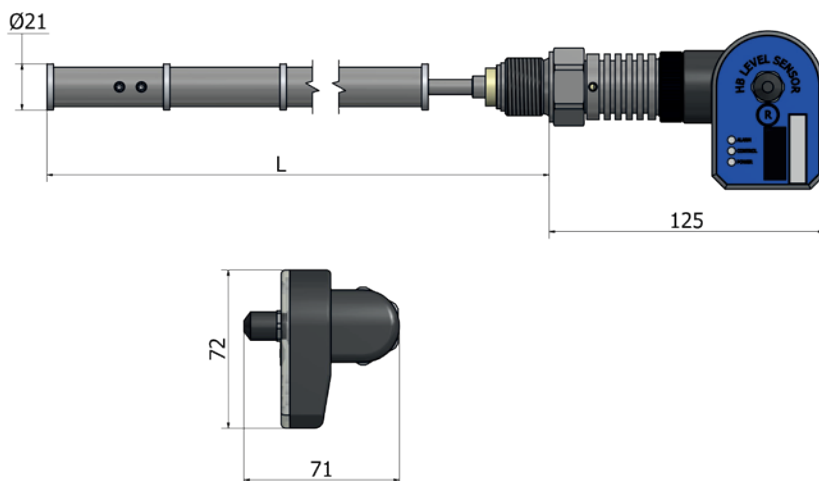

## Ordering codes

Length	Thread type	Without integrated cable	Modulating valve*	Stepper motor valve**	Pulse width modulation***
200 mm	3/4" NPT	HBLT-FLEX-2-2	HBSLT-FLEX/C-2-2	HBSLT-FLEX/S-2-2	HBSLT-FLEX/PWM-2-2
200 mm	3/4" BSPP	HBLT-FLEX-2-6	HBSLT-FLEX/C-2-6	HBSLT-FLEX/S-2-6	HBSLT-FLEX/PWM-2-6
300 mm	3/4" NPT	HBLT-FLEX-3-2	HBSLT-FLEX/C-3-2	HBSLT-FLEX/S-3-2	HBSLT-FLEX/PWM-3-2
300 mm	3/4" BSPP	HBLT-FLEX-3-6	HBSLT-FLEX/C-3-6	HBSLT-FLEX/S-3-6	HBSLT-FLEX/PWM-3-6
400 mm	3/4" NPT	HBLT-FLEX-4-2	HBSLT-FLEX/C-4-2	HBSLT-FLEX/S-4-2	HBSLT-FLEX/PWM-4-2
400 mm	3/4" BSPP	HBLT-FLEX-4-6	HBSLT-FLEX/C-4-6	HBSLT-FLEX/S-4-6	HBSLT-FLEX/PWM-4-6
500 mm	3/4" NPT	HBLT-FLEX-5-2	HBSLT-FLEX/C-5-2	HBSLT-FLEX/S-5-2	HBSLT-FLEX/PWM-5-2
500 mm	3/4" BSPP	HBLT-FLEX-5-6	HBSLT-FLEX/C-5-6	HBSLT-FLEX/S-5-6	HBSLT-FLEX/PWM-5-6
600 mm	3/4" NPT	HBLT-FLEX-6-2	HBSLT-FLEX/C-6-2	HBSLT-FLEX/S-6-2	HBSLT-FLEX/PWM-6-2
600 mm	3/4" BSPP	HBLT-FLEX-6-6	HBSLT-FLEX/C-6-6	HBSLT-FLEX/S-6-6	HBSLT-FLEX/PWM-6-6
700 mm	3/4" NPT	HBLT-FLEX-7-2	HBSLT-FLEX/C-7-2	HBSLT-FLEX/S-7-2	HBSLT-FLEX/PWM-7-2
700 mm	3/4" BSPP	HBLT-FLEX-7-6	HBSLT-FLEX/C-7-6	HBSLT-FLEX/S-7-6	HBSLT-FLEX/PWM-7-6
800 mm	3/4" NPT	HBLT-FLEX-8-2	HBSLT-FLEX/C-8-2	HBSLT-FLEX/S-8-2	HBSLT-FLEX/PWM-8-2
800 mm	3/4" BSPP	HBLT-FLEX-8-6	HBSLT-FLEX/C-8-6	HBSLT-FLEX/S-8-6	HBSLT-FLEX/PWM-8-6
900 mm	3/4" NPT	HBLT-FLEX-9-2	HBSLT-FLEX/C-9-2	HBSLT-FLEX/S-9-2	HBSLT-FLEX/PWM-9-2
900 mm	3/4" BSPP	HBLT-FLEX-9-6	HBSLT-FLEX/C-9-6	HBSLT-FLEX/S-9-6	HBSLT-FLEX/PWM-9-6
1200 mm	3/4" NPT	HBLT-FLEX-12-2	HBSLT-FLEX/C-12-2	HBSLT-FLEX/S-12-2	HBSLT-FLEX/PWM-12-2
1200 mm	3/4" BSPP	HBLT-FLEX-12-6	HBSLT-FLEX/C-12-6	HBSLT-FLEX/S-12-6	HBSLT-FLEX/PWM-12-6
1400 mm	3/4" NPT	HBLT-FLEX-14-2	HBSLT-FLEX/C-14-2	HBSLT-FLEX/S-14-2	HBSLT-FLEX/PWM-14-2
1400 mm	3/4" BSPP	HBLT-FLEX-14-6	HBSLT-FLEX/C-14-6	HBSLT-FLEX/S-14-6	HBSLT-FLEX/PWM-14-6
1600 mm	3/4" NPT	HBLT-FLEX-16-2	HBSLT-FLEX/C-16-2	HBSLT-FLEX/S-16-2	HBSLT-FLEX/PWM-16-2
1600 mm	3/4" BSPP	HBLT-FLEX-16-6	HBSLT-FLEX/C-16-6	HBSLT-FLEX/S-16-6	HBSLT-FLEX/PWM-16-6
1800 mm	3/4" NPT	HBLT-FLEX-18-2	HBSLT-FLEX/C-18-2	HBSLT-FLEX/S-18-2	HBSLT-FLEX/PWM-18-2
1800 mm	3/4" BSPP	HBLT-FLEX-18-6	HBSLT-FLEX/C-18-6	HBSLT-FLEX/S-18-6	HBSLT-FLEX/PWM-18-6
2000 mm	3/4" NPT	HBLT-FLEX-20-2	HBSLT-FLEX/C-20-2	HBSLT-FLEX/S-20-2	HBSLT-FLEX/PWM-20-2
2000 mm	3/4" BSPP	HBLT-FLEX-20-6	HBSLT-FLEX/C-20-6	HBSLT-FLEX/S-20-6	HBSLT-FLEX/PWM-20-6

\*For direct control of a modulating valve such as Siemens MVS661.

\*\*For direct control of a stepper motor valve such as Carel.

\*\*\*For direct control of a pulse width modulation valve such as Danfoss AKVA.

# CO<sub>2</sub> Liquid Level Sensor

## Category: HBLC-CO<sub>2</sub> & HBSLC-CO<sub>2</sub>

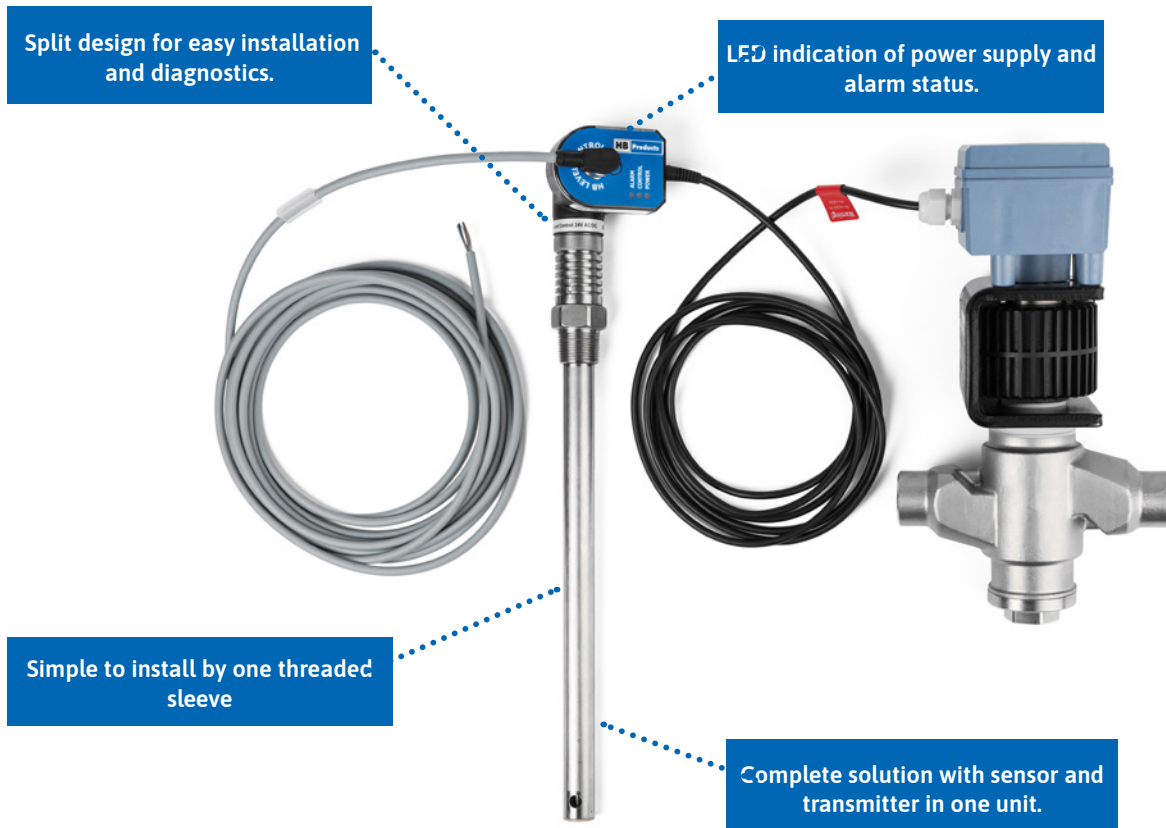

### Functional description:

HBLC-CO<sub>2</sub> is an intelligent sensor with a built-in microprocessor. It is designed for continuous level measurement of liquid CO<sub>2</sub> refrigerant in refrigeration systems.

HBLC-CO<sub>2</sub> is designed for the measurement of CO<sub>2</sub> refrigerant level in chillers, evaporators and condensers.

The sensor emits a 4-20mA analog signal, which is proportional to the liquid level.

The construction of the sensor makes it suitable for systems with pressure of up to 150 bar.

The sensor is delivered in a version without integrated cable (named HBLC) and a version with cable for direct control of valves (named HBSLC).

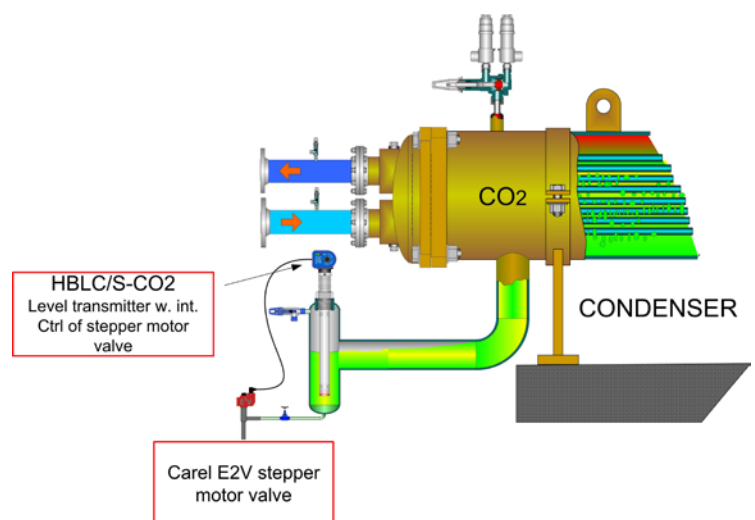

## Technical data - sensor

Supply		Mechanical Specifications	
Supply:	24 V AC/DC ±10%*	Thread connection	3/4" NPT & BSPP
Current consumption - sensor only*	Max 50 mA	Materials - mechanical parts:	AISI304/PTFE
Plug	M12, 5 pins - DIN 0627	Materials - electronic parts:	Nylon 6 (PA)
		Dimensions	See drawing
Output		Installation conditions:	
Analog output	4-20 mA	Ambient temperature	-30...+50°C
Permitted load on potential free contactless set	1A (24V DC)	Refrigerant temperature	-55...+30°C
LED indication	Green, yellow, and red	Max. operational pressure:	150 bar
Cable specification		Protection degree	IP66
Supply cable, 5 meters	HBxC-M12/5	Vibrations	IEC 68-2-6 (4g)
Vibrations	PUR - 5 x 0,34 mm <sup>2</sup>		
Approvals			
EMC Emission:	EN61000-3-2		
EMC Immunity:	EN61000-4-2		

\* Total consumption is sensor consumption plus output and it depends on ambient temperature.

## Mechanical dimensions

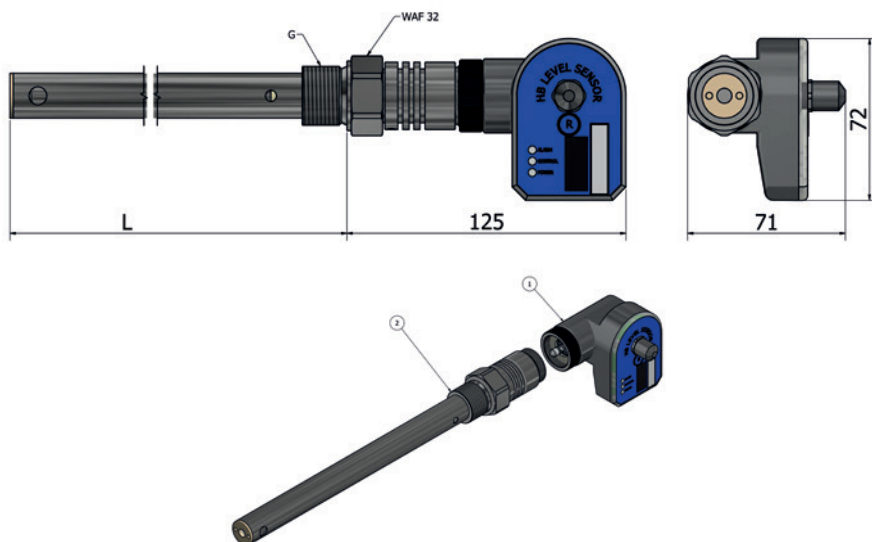

## Spare parts

Position	Specification	Type	Ordering code
1	Mechanical part	Mechanical part for HBLC-CO2	HBLC-NH3-XXX-MEK*
2	Electronic part	Electronic part for HBLC-CO2 - With LED	HBLC-CO2-EL-LED*

\*When ordering mechanical parts please inform about length- and thread type.

\*Electronic parts must be calibrated on-site

## Ordering codes

Length	Length/Thread	Without cable	Modulating valve*	Stepper motor**	Pulse width modulation valve***
200 mm	3/4" NPT	HBLC-CO2-2-2	HBSLC/C-CO2-2-2	HBSLC/S-CO2-2-2	HBSLC/PWM-CO2-2-2
200 mm	3/4" BSPP	HBLC-CO2-2-6	HBSLC/C-CO2-2-6	HBSLC/S-CO2-2-6	HBSLC/PWM-CO2-2-6
300 mm	3/4" NPT	HBLC-CO2-3-2	HBSLC/C-CO2-3-2	HBSLC/S-CO2-3-2	HBSLC/PWM-CO2-3-2
300 mm	3/4" BSPP	HBLC-CO2-3-6	HBSLC/C-CO2-3-6	HBSLC/S-CO2-3-6	HBSLC/PWM-CO2-3-6
400 mm	3/4" NPT	HBLC-CO2-4-2	HBSLC/C-CO2-4-2	HBSLC/S-CO2-4-2	HBSLC/PWM-CO2-4-2
400 mm	3/4" BSPP	HBLC-CO2-4-6	HBSLC/C-CO2-4-6	HBSLC/S-CO2-4-6	HBSLC/PWM-CO2-4-6
500 mm	3/4" NPT	HBLC-CO2-5-2	HBSLC/C-CO2-5-2	HBSLC/S-CO2-5-2	HBSLC/PWM-CO2-5-2
500 mm	3/4" BSPP	HBLC-CO2-5-6	HBSLC/C-CO2-5-6	HBSLC/S-CO2-5-6	HBSLC/PWM-CO2-5-6
600 mm	3/4" NPT	HBLC-CO2-6-2	HBSLC/C-CO2-6-2	HBSLC/S-CO2-6-2	HBSLC/PWM-CO2-6-2
600 mm	3/4" BSPP	HBLC-CO2-6-6	HBSLC/C-CO2-6-6	HBSLC/S-CO2-6-6	HBSLC/PWM-CO2-6-6
700 mm	3/4" NPT	HBLC-CO2-7-2	HBSLC/C-CO2-7-2	HBSLC/S-CO2-7-2	HBSLC/PWM-CO2-7-2
700 mm	3/4" BSPP	HBLC-CO2-7-6	HBSLC/C-CO2-7-6	HBSLC/S-CO2-7-6	HBSLC/PWM-CO2-7-6
800 mm	3/4" NPT	HBLC-CO2-8-2	HBSLC/C-CO2-8-2	HBSLC/S-CO2-8-2	HBSLC/PWM-CO2-8-2
800 mm	3/4" BSPP	HBLC-CO2-8-6	HBSLC/C-CO2-8-6	HBSLC/S-CO2-8-6	HBSLC/PWM-CO2-8-6
900 mm	3/4" NPT	HBLC-CO2-9-2	HBSLC/C-CO2-9-2	HBSLC/S-CO2-9-2	HBSLC/PWM-CO2-9-2
900 mm	3/4" BSPP	HBLC-CO2-9-6	HBSLC/C-CO2-9-6	HBSLC/S-CO2-9-6	HBSLC/PWM-CO2-9-6
1000 mm	3/4" NPT	HBLC-CO2-10-2	HBSLC/C-CO2-10-2	HBSLC/S-CO2-10-2	HBSLC/PWM-CO2-10-2
1000 mm	3/4" BSPP	HBLC-CO2-10-6	HBSLC/C-CO2-10-6	HBSLC/S-CO2-10-6	HBSLC/PWM-CO2-10-6
1100 mm	3/4" NPT	HBLC-CO2-11-2	HBSLC/C-CO2-11-2	HBSLC/S-CO2-11-2	HBSLC/PWM-CO2-11-2
1100 mm	3/4" BSPP	HBLC-CO2-11-6	HBSLC/C-CO2-11-6	HBSLC/S-CO2-11-6	HBSLC/PWM-CO2-11-6
1200 mm	3/4" NPT	HBLC-CO2-12-2	HBSLC/C-CO2-12-2	HBSLC/S-CO2-12-2	HBSLC/PWM-CO2-12-2
1200 mm	3/4" BSPP	HBLC-CO2-12-6	HBSLC/C-CO2-12-6	HBSLC/S-CO2-12-6	HBSLC/PWM-CO2-12-6
1300 mm	3/4" NPT	HBLC-CO2-13-2	HBSLC/C-CO2-13-2	HBSLC/S-CO2-13-2	HBSLC/PWM-CO2-13-2
1300 mm	3/4" BSPP	HBLC-CO2-13-6	HBSLC/C-CO2-13-6	HBSLC/S-CO2-13-6	HBSLC/PWM-CO2-13-6
1400 mm	3/4" NPT	HBLC-CO2-14-2	HBSLC/C-CO2-14-2	HBSLC/S-CO2-14-2	HBSLC/PWM-CO2-14-2
1400 mm	3/4" BSPP	HBLC-CO2-14-6	HBSLC/C-CO2-14-6	HBSLC/S-CO2-14-6	HBSLC/PWM-CO2-14-6
1500 mm	3/4" NPT	HBLC-CO2-15-2	HBSLC/C-CO2-15-2	HBSLC/S-CO2-15-2	HBSLC/PWM-CO2-15-2
1500 mm	3/4" BSPP	HBLC-CO2-15-6	HBSLC/C-CO2-15-6	HBSLC/S-CO2-15-6	HBSLC/PWM-CO2-15-6
1700 mm	3/4" NPT	HBLC-CO2-17-2	HBSLC/C-CO2-17-2	HBSLC/S-CO2-17-2	HBSLC/PWM-CO2-17-2
1700 mm	3/4" BSPP	HBLC-CO2-17-6	HBSLC/C-CO2-17-6	HBSLC/S-CO2-17-6	HBSLC/PWM-CO2-17-6
2000 mm	3/4" NPT	HBLC-CO2-20-2	HBSLC/C-CO2-20-2	HBSLC/S-CO2-20-2	HBSLC/PWM-CO2-20-2
2000 mm	3/4" BSPP	HBLC-CO2-20-6	HBSLC/C-CO2-20-6	HBSLC/S-CO2-20-6	HBSLC/PWM-CO2-20-6
2500 mm	3/4" NPT	HBLC-CO2-25-2	HBSLC/C-CO2-25-2	HBSLC/S-CO2-25-2	HBSLC/PWM-CO2-25-2
2500 mm	3/4" BSPP	HBLC-CO2-25-6	HBSLC/C-CO2-25-6	HBSLC/S-CO2-25-6	HBSLC/PWM-CO2-25-6
3000 mm	3/4" NPT	HBLC-CO2-30-2	HBSLC/C-CO2-30-2	HBSLC/S-CO2-30-2	HBSLC/PWM-CO2-30-2
3000 mm	3/4" BSPP	HBLC-CO2-30-6	HBSLC/C-CO2-30-6	HBSLC/S-CO2-30-6	HBSLC/PWM-CO2-30-6

\*For direct control of a modulating valve such as Siemens MVS661.

\*\*For direct control of a stepper motor valve such as Carel.

\*\*\*For direct control of a pulse width modulation valve such as Danfoss AKVA.

# Level Controller

Category: HBLT-C1 & HBMD-L



HBLT-C1



New

HBMD-L

## Functional description:

HBLT-C1 is designed for level control in vessels in industrial refrigeration systems. It can be used in connection with the HBLC-CO<sub>2</sub> analog level sensor or other similar sensors with a 4-20 mA output signal. To be used in:

- Pump vessels
- Separators
- Intercoolers
- Economizers
- Condensers
- Receivers

HBMD-L is a display for showing the level value directly like the display on the level sensor. The display can be installed anywhere on the cable between a level sensor and the PLC using M12 cables.

The sensor is supplied with a 5 m M12 extension cable.

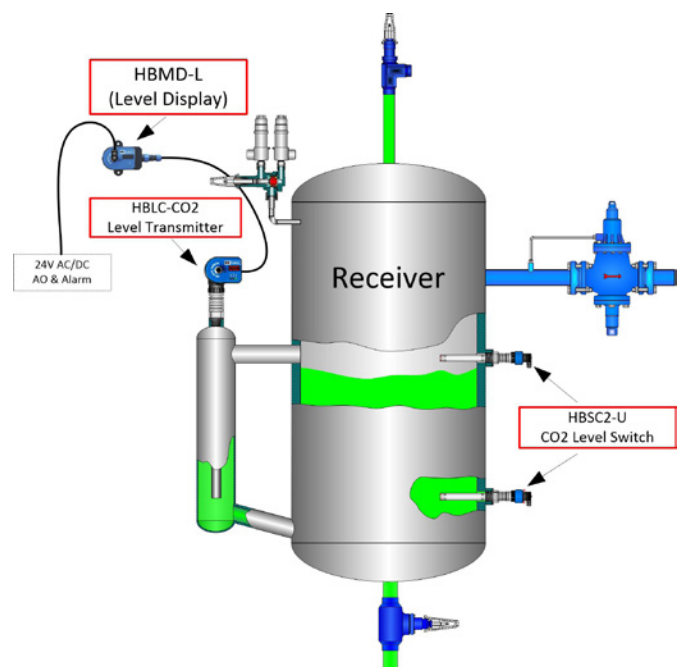

## Technical data

Supply	HBLT-C1	HBLT-C1-ENC	HBMD-L
Voltage	24 V AC/DC ± 10 %	100..240 V AC or 24 V AC/DC	24 V AC/DC ± 10 %
Frequency	50/60 Hz	50/60 Hz	50/60 Hz
Current consumption - sensor only*	Max 40 mA	Max 1.5 A	Max 40 mA
Connection	Screw terminal	Screw terminal	Plug
Wire size	< 2.5 mm <sup>2</sup>	< 2.5 mm <sup>2</sup>	< 2.5 mm <sup>2</sup>
<b>Installation conditions:</b>			
Surrounding temperature	-20...+70°C	-20...+70°C	-40...+70°C
Protection class	IP45	IP65	IP65
Relative humidity	20...80 %	20...80 %	20...80 %
<b>Approvals:</b>			
EMC Emission	EN61000-3-2	EN61000-3-2	EN61000-3-2
EMC Immunity	EN61000-4-2	EN61000-4-2	EN61000-4-2
<b>Mechanical specifications:</b>			
Mounting	In front of panel	In cabinet/casing for mounting on a wall	Wall mounting
External measurement	(96x96x94 (WxHxD))	298x198x182 mm (WxHxD)	100x81x40 mm (WxHxD)
Cut-out measurement	92.8x92.8 mm	N.A.	N/A
Material	Plastic	Plastic	Plastic
Weight	0.2 kg	1.4 kg	0.3 kg
<b>Display:</b>			
Digit's display	3 digits, red	3 digits, red	3 digits, red
Alarm indication	LED (green og red)	LED (green og red)	N/A
Programming	From front	From front	HB Tool
Updating	1 time each second	1 time each second	1 time each second
<b>Input:</b>			
Analog input - sensor	4-20 mA	4-20 mA	4-20 mA
<b>Output:</b>			
Analog output	4-20 mA	4-20 mA	4-20 mA
Load	3A/24 VDC	3A/24 VDC	3A/24 VDC
Relay output	@24VAC/VDC: 3 x 3A @110 V AC: 3 x 5A @220 V AC: 3 x 5A	@24VAC/VDC: 3 x 3A @110 V AC: 3 x 5A @220 V AC: 3 x 5A	@24VAC/VDC: 3 x 3A @110 V AC: 3 x 5A @220 V AC: 3 x 5A

\* Total consumption is sensor consumption plus output and it depends on ambient temperature.

## Ordering codes

Cabinet design	Ordering code
Controller - 24 V AC/DC power supply	HBLT-C1
Controller build in a cabinet & mounted with 110/240 V power supply	HBLT-C1-ENC
Multi-display - can be used as a local level display - 24 V AC/DC power supply	HBMD-L

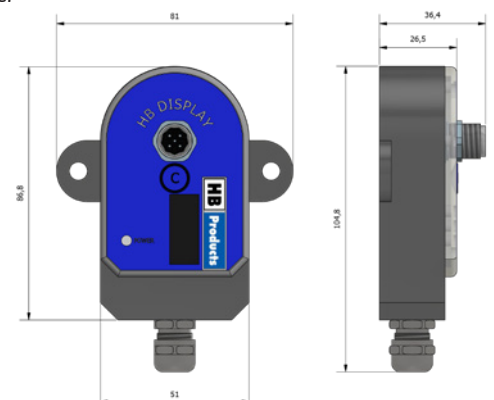

# CO<sub>2</sub> Gas Leakage Alarm/Sensor

Category: HBGS

The sensor element can easily be replaced if needed and requires no calibration.

The sensor is factory calibrated. The sensor comes with a calibration certificate as well as with configured alarm limits.

Integrated LEDs for display of the supply (green) as well as 3 alarm levels (red, orange, and yellow).

Reset button in case an alarm is triggered.

Supply voltage : 24 V DC  
Power consumption  
max 3 watt



Alarm limits: 0...10000 ppm (can be configured with HB-tool)

Standard factory settings:

Alarm A: 8000 ppm NO/NC (Main alarm acc. to EN378)

Alarm B: 5000 ppm NO/NC (Pre-alarm acc. to EN 378)

Alarm C: 2000 ppm NO/NC (Pre-alarm acc. to EN 378)

The HBGS can also be ordered with customized default settings based on specific customer needs

## Functional description:

HBGS fulfils the requirements for gas leakage measurement in accordance with F-GAS regulation EU/517/2014. HBGS detects CO<sub>2</sub> (R744) in a range of 0...10000 ppm. It is an independent unit that must be supplied with 24 V DC. It has 3 built-in digital alarm output and 1 analog 4... 20 mA output. The sensor can be set up using a PC with the HB Configuration Tool.

The CO<sub>2</sub> sensor version has a lifetime of more than 5 years. Both sensor elements can easily be replaced and does not require a new calibration. On the front, you can find 4 integrated LEDs for display of the supply (green) as well as 3 alarm levels (red, orange, and yellow). Similarly, there is a reset button in case an alarm is

triggered. The sensor is factory calibrated. Verification during the lifetime can be done with high gas concentrations. The sensor is optimized for use in areas where cleaning solvents are used. Built-in heating element ensures low ambient temperatures down to -30 ° C. The sensor comes with a calibration certificate as well as with preconfigured alarm limits.



## Technical data

Electrical connection		Mechanical specifications	
Measuring accuracy	+/-2%	Cabinet size	82x59x126mm
Connection	Screw terminals		
Cable connection	2xPG7	Material	Plastic
Supply voltage	24 V DC – Power consumption max 3watt	Mounting	On walls with screws
Analog output	4...20 mA	Alarm	Can be configured with HB-tool
Max load:	500 ohm	Alarm limits	0 to 10000 ppm
Digital output - relay:	3 x SPDT, 0.5A	Alarm A	8000 ppm NO/NC (Main alarm acc. to EN378)
		Alarm B	5000 ppm NO/NC (Pre-alarm acc. to EN 378)
		Alarm C	2000 ppm NO/NC (Pre-alarm acc. to EN 378)
Installation conditions		Approvals	
Ambient temperature:	-30...+50°C	EMC Emission	EN 61000-3-2
Protection degree	IP20, box IP65	EMC Immunity	EN 61000-4-2
Vibrations	IEC 68-2-6 (4g)		

## Mechanical dimensions

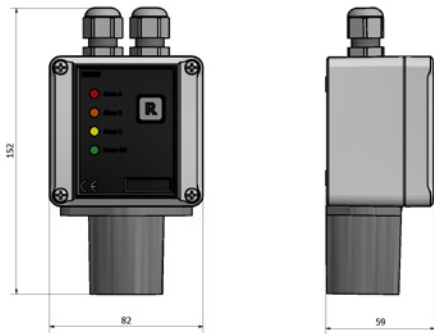

## Ordering codes

House design	Gas	Measuring area	Ordering code
Front	CO2 (R744)	0... 10000 ppm	HBGS-CO2



HBGS ServiceKit

## Spare parts

Accessories for test and calibration	Gas	Ordering code
Part no. Sensor Part	CO2 (R744)	HBGS-CO2-Unit
Part no. Service kit	CO2 (R744)	HBGS-NH3-ServiceKit
Part no. Siren/flash light	CO2 (R744)	Sounder Beacon



## HFC/HFO - Refrigerants

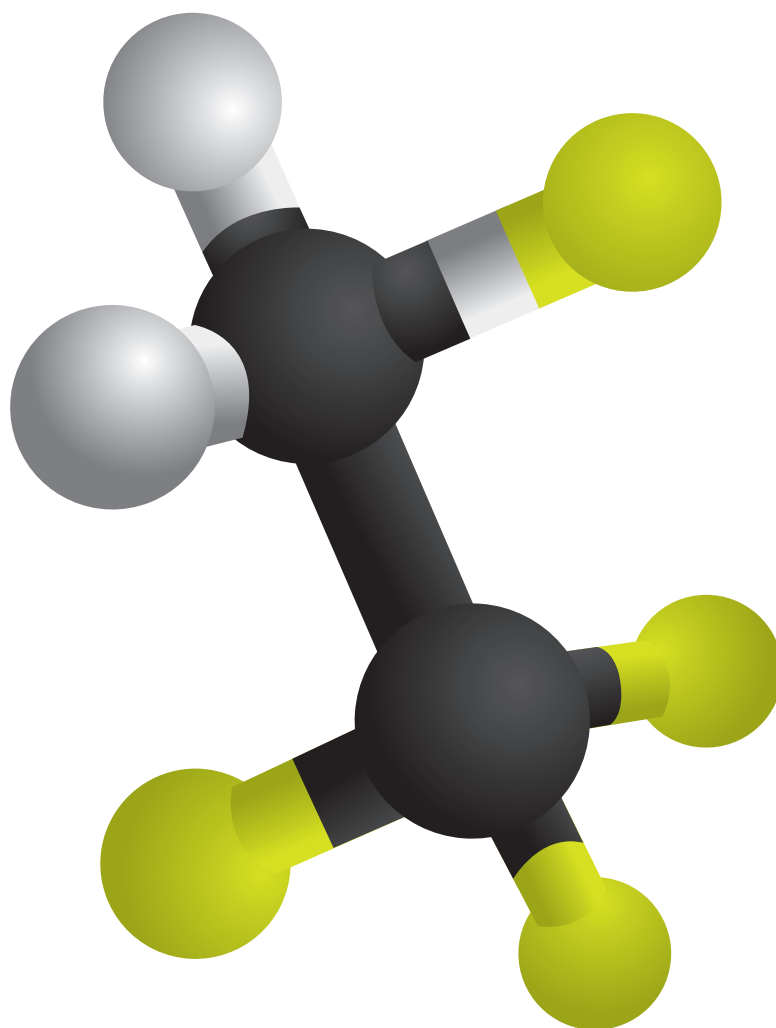

# Switches, Sensors and Controllers for HFC/HFO Refrigeration Installations

ON/OFF Switches			
HFC liquid	<b>Function:</b> HFC Liquid Level Switch - 24 V AC/DC <b>Application:</b> Level switch in vessels <b>Refrigerant Temperature:</b> -60...+80°C <b>Supply:</b> 24 V AC/DC <b>Output:</b> PNP/NPN - 1A		Page 100
	<b>Function:</b> HFC Liquid Level Switch - 90...240 V AC <b>Application:</b> Level switch in vessels <b>Refrigerant Temperature:</b> -60...+80°C <b>Supply:</b> 90...240 V AC <b>Output:</b> Solid state relay - 1A		Page 104
	<b>Function:</b> HFC Liquid Level Switch - Low Temperature <b>Application:</b> Level switch in flow freezers <b>Refrigerant Temperature:</b> -60...+80°C <b>Supply:</b> 24 V DC <b>Output:</b> Solid state relay		Page 106
HFC GAS	<b>Function:</b> Compressor Protection <b>Application:</b> Compressor protection sensor <b>Refrigerant Temperature:</b> -60...+80°C <b>Supply:</b> 24 V AC/DC <b>Output:</b> PNP/NPN - 1A		Page 108
Sensor and Controllers			
HFC liquid	<b>Function:</b> HFC Level Sensor - Wire <b>Applications:</b> Level measurement in standpipes <b>Refrigerant Temperature:</b> -60...+80°C <b>Supply:</b> 24 V AC/DC <b>Output:</b> 4...20 mA / PNP-1A		Page 111
	<b>Function:</b> Level Sensor - Flex (HFC / HFO / CO <sub>2</sub> ) <b>Applications:</b> Level measurement in standpipes <b>Refrigerant Temperature:</b> -60...+60°C <b>Supply:</b> 24 V AC/DC <b>Output:</b> 4...20 mA / PNP-1A		Page 115
	<b>Function:</b> HFC Liquid Level Sensor <b>Applications:</b> Chillers, evaporators and condensers <b>Refrigerant Temperature:</b> -60...+80°C <b>Supply:</b> 24 V AC/DC <b>Output:</b> 4...20 mA / PNP-1A		Page 118
	<b>Function:</b> Level Controller <b>Applications:</b> Level control on e.g. pump separators <b>Supply:</b> 24 V AC/DC / 100-240 V AC <b>Output:</b> 4...20 mA / 3x solid state relay - 3/5A		Page 121
GAS	<b>Function:</b> F-gas Level Sensor <b>Applications:</b> HFC applications - To comply with F-gas regulations <b>Refrigerant Temperature:</b> -60...+80°C <b>Supply:</b> 24 V AC/DC <b>Output:</b> 4-20mA		Page 123

# HFC Liquid Level Switch - 24 V AC/DC

Category: HBSR-U-HFC & HBSR-U-L-HFC

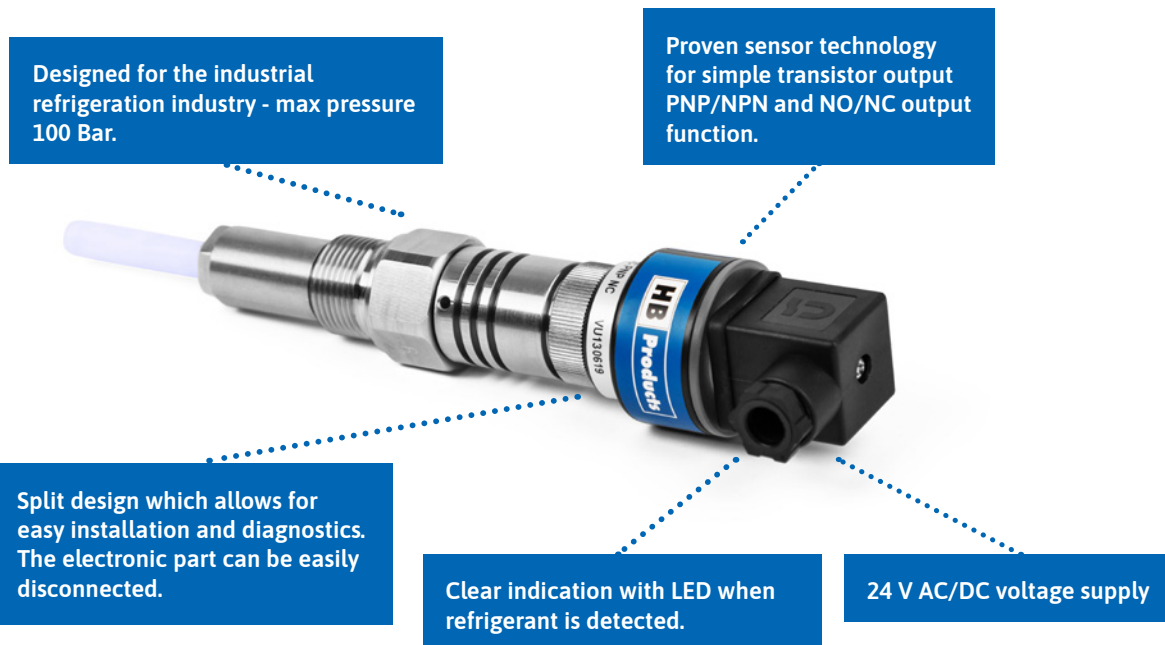

## Functional description

HBSR-U is a level switch for the detection of HFC refrigerants.

Typically it is installed in/on the refrigerant vessels, pump separators, economizers or heat exchangers.

The switch is specially built to resist high pressure and low temperatures.

- For almost 20 years switches from HB Products has been supplied worldwide.
- More than 10.000 switches are produced every year.
- We deliver switches as OEM products to the leading suppliers of industrial refrigeration equipment.

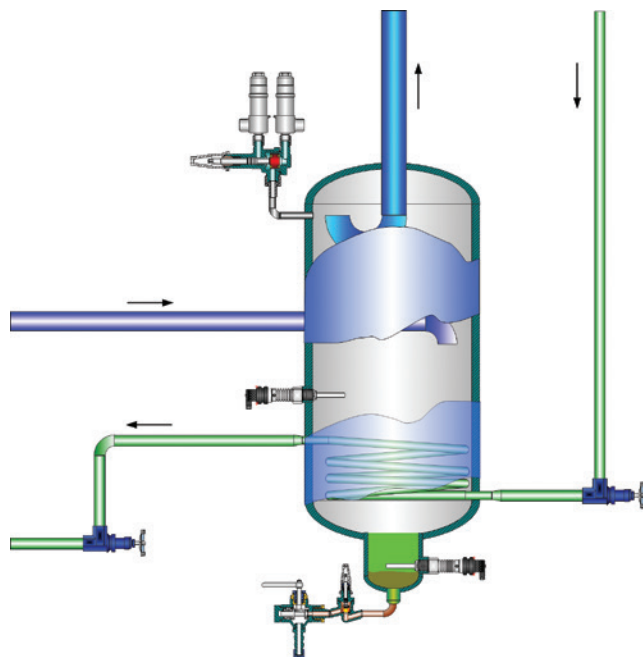

## Technical data

Power supply		Mechanical specifications	
Voltage	24 V AC/DC + 10%	Thread connection	NPT / BSPP / BSPT
Max. current output	200 mA	Material – mechanical parts	AISI 304 / PTFE
Current consumption - sensor only*	< 10 mA	Material – electronic parts	Nylon 6 (PA)
Plug connection	ISO 4400/DIN 43650	Dimensions for HBSR-U	209x51x45
<b>Output</b>		Dimensions for HBSR-U-L	259x101x45
Output type	PNP or NPN - 50 mA	<b>Environmental conditions</b>	
Output function	NC or NO	Ambient temperature	-30...+50°C
LED indication	4 x LED (red)	Refrigerant temperature	-60...+80°C***
<b>Cable specification**</b>		Max pressure	100 bar
Cable size	3 x 0.34 mm <sup>2</sup>	Protection degree	IP6
Cable glands	PG7 / M8	Vibrations	IEC 68-2-6 (4g)
Cable resistance	500 Ω/Km		
<b>Approvals</b>			
CE	EN 61000-2		

\* Total consumption is sensor consumption plus output and it depends on ambient temperature.

\*\* Cable not included

\*\*\* Max temperature specified for R134a.

For R410a, R507, R22, R1234ze & R1234yf the max temperature is +40 °C

### Mechanical dimensions for HBSR-U

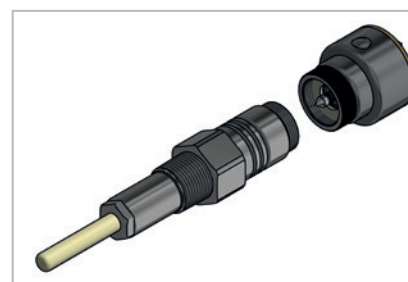
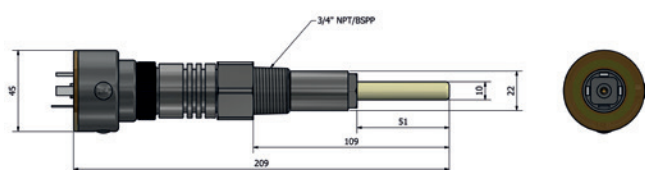

### Mechanical dimensions for HBSR-U-L

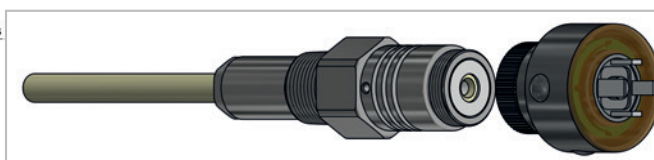
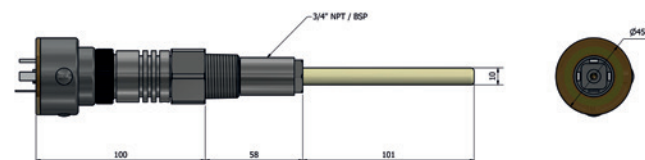

Thread to be sealed with conductive liquid sealing to ensure ground connection.

### Ordering codes for HBSR-U

Output	Thread type (G)	Ordering code
PNP / NO	1/2" NPT	HBSR-U-HFC-PNP/NO-1
PNP / NC	1/2" NPT	HBSR-U-HFC-PNP/NC-1
PNP / NO	3/4" NPT	HBSR-U-HFC-PNP/NO-2
PNP / NC	3/4" NPT	HBSR-U-HFC-PNP/NC-2
PNP / NO	3/4" BSPT	HBSR-U-HFC-PNP/NO-4
PNP / NC	3/4" BSPT	HBSR-U-HFC-PNP/NC-4
PNP / NO	1/2" BSPP	HBSR-U-HFC-PNP/NO-5
PNP / NC	1/2" BSPP	HBSR-U-HFC-PNP/NC-5
PNP / NO	3/4" BSPP	HBSR-U-HFC-PNP/NO-6
PNP / NC	3/4" BSPP	HBSR-U-HFC-PNP/NC-6
NPN / NO	1/2" NPT	HBSR-U-HFC-NPN/NO-1
NPN / NC	1/2" NPT	HBSR-U-HFC-NPN/NC-1
NPN / NO	3/4" NPT	HBSR-U-HFC-NPN/NO-2
NPN / NC	3/4" NPT	HBSR-U-HFC-NPN/NC-2
NPN / NO	3/4" BSPT	HBSR-U-HFC-NPN/NO-4
NPN / NC	3/4" BSPT	HBSR-U-HFC-NPN/NC-4
NPN / NO	1/2" BSPP	HBSR-U-HFC-NPN/NO-5
NPN / NC	1/2" BSPP	HBSR-U-HFC-NPN/NC-5
NPN / NO	3/4" BSPP	HBSR-U-HFC-NPN/NO-6
NPN / NC	3/4" BSPP	HBSR-U-HFC-NPN/NC-6

### Ordering codes for HBSR-U-L

Output	Thread type (G)	Length	Ordering code
PNP / NO	3/4" NPT	160 mm	HBSR-U-L-HFC-PNP/NO-2
PNP / NC	3/4" NPT	160 mm	HBSR-U-L-HFC-PNP/NC-2
PNP / NO	3/4" BSPT	160 mm	HBSR-U-L-HFC-PNP/NO-4
PNP / NC	3/4" BSPT	160 mm	HBSR-U-L-HFC-PNP/NC-4
PNP / NO	3/4" BSPP	160 mm	HBSR-U-L-HFC-PNP/NO-6
PNP / NC	3/4" BSPP	160 mm	HBSR-U-L-HFC-PNP/NC-6
NPN / NO	3/4" NPT	160 mm	HBSR-U-L-HFC-NPN/NO-2
NPN / NC	3/4" NPT	160 mm	HBSR-U-L-HFC-NPN/NC-2
NPN / NO	3/4" BSPT	160 mm	HBSR-U-L-HFC-NPN/NO-4
NPN / NC	3/4" BSPT	160 mm	HBSR-U-L-HFC-NPN/NC-4
NPN / NO	3/4" BSPP	160 mm	HBSR-U-L-HFC-NPN/NO-6
NPN / NC	3/4" BSPP	160 mm	HBSR-U-L-HFC-NPN/NC-6

4 x red LED's indicate liquid detection.  
 4 x green LED's flashing indicate no detection, but sensor is active.  
 4 x red flashing LED's indicate no connection to mechanical unit.

#### Switch contact output:

**NC:** Relay contact is normally closed (current can flow) and opens when liquid is detected.

**NO:** Relay contact is normally open (no current flow) and closes when liquid is detected.

**Spare parts for HBSR-U, HBSR-U-L & HBSR**

Product	Specification	Type	Ordering code
HBSR-U-HFC	Electronic parts	PNP/NO	HBSR-U-HFC-EL/PNP/NO
		PNP/NC	HBSR-U-HFC-EL/PNP/NC
		NPN/NO	HBSR-U-HFC-EL/NPN/NO
		NPN/NC	HBSR-U-HFC-EL/NPN/NC
HBSR-U-HFC	Mechanical parts	1/2" NPT	HBSR-U-HFC-MEK-1
		3/4" NPT	HBSR-U-HFC-MEK-2
		3/4" BSPT	HBSR-U-HFC-MEK-4
		1/2" BSPP	HBSR-U-HFC-MEK-5
		3/4" BSPP	HBSR-U-HFC-MEK-6
HBSR-U-L-HFC	Electronic parts	PNP/NO	HBSR-U-L-HFC-EL/PNP/NO
		PNP/NC	HBSR-U-L-HFC-EL/PNP/NC
		NPN/NO	HBSR-U-L-HFC-EL/NPN/NO
		NPN/NC	HBSR-U-L-HFC-EL/NPN/NC
HBSR-U-L-HFC	Mechanical parts	3/4" NPT	HBSR-U-L-HFC-MEK-2
		3/4" BSPT	HBSR-U-L-HFC-MEK-4
		3/4" BSPP	HBSR-U-L-HFC-MEK-6
HBSR	Electronic parts	PNP/NO	HBSR-EL/PNP/NO
		PNP/NC	HBSR-EL/PNP/NC
		NPN/NO	HBSR-EL/NPN/NO
		NPN/NC	HBSR-EL/NPN/NC

# HFC Liquid Level Switch - 90...240 V AC

Category: HBSR-U-SSR2

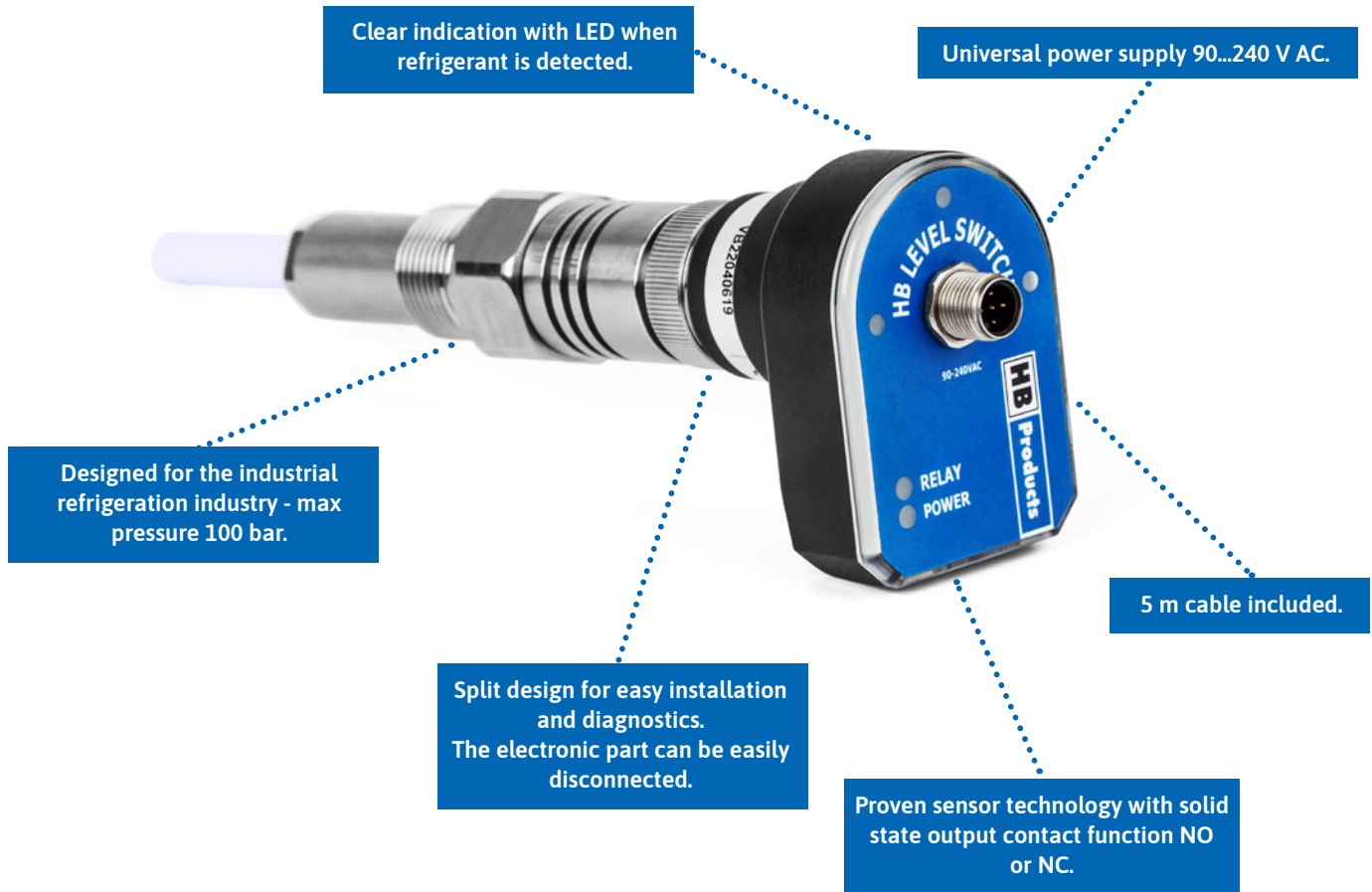

## Functional description

HBSR-U-SSR2 is a level switch for the detection of HFC refrigerants.

Typically it is installed in/on the refrigerant vessels, pump separators, economizers or heat exchanger.

The sensor is specially built to resist high pressure and low temperatures.

The switch has a built-in local power supply for direct use on grid supply 90...240 V AC. A solid state relay can also operate a valve directly.

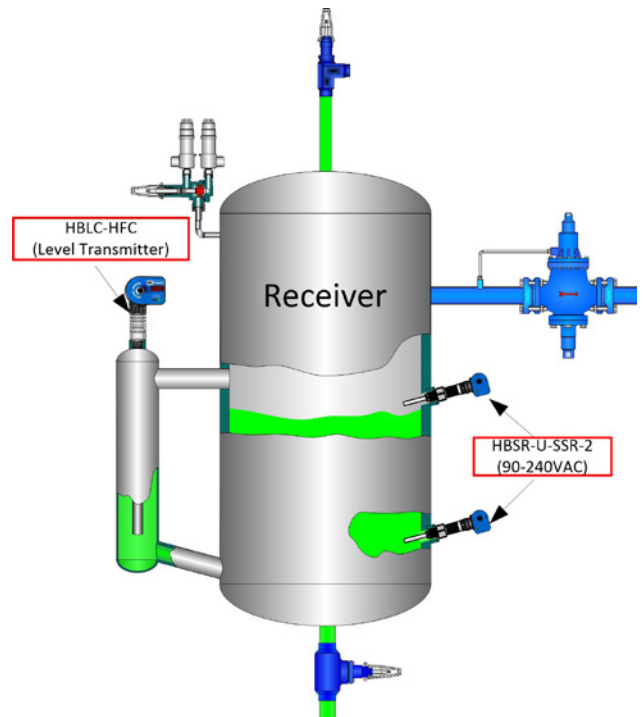



## Technical data

Power supply		Approvals	
Supply	90...240 V AC	CE	EN 61000-2
Current consumption - sensor only*	<10 mA	Mechanical specifications	
Plug connection	M12 - DIN 0627	Thread connection	3/4" NPT / BSPP
Output		Material - mechanical parts	AISI 304 / PTFE
Solid state relay output	90...240 V AC - 40 W	Material - electronic parts	Nylon 6 (PA)
Output function	NC or NO	Dimensions	See drawing
Cable specification (power supply)		Environmental conditions	
Cable size	5 m - 3 x 0.25 mm <sup>2</sup>	Ambient temperature	-30...+50°C
Cable glands	PG7 / M8	Refrigerant temperature	-60...+80°C**
Cable resistance	500 Ω/Km	Max pressure	100 bar
Indication		Protection degree	IP65
Level indication	3 x LED (green)	Vibrations	IEC 68-2-6 (4g)
Relay-on activation	1 x LED (yellow)		
Power supply	1 x LED (green)		

\* Total consumption is sensor consumption plus output and it depends on ambient temperature.

\*\* Max temperature specified for R134a.

For R410a, R507, R22, R1234ze & R1234yf the max temperature is +40 °C.

## Mechanical dimensions

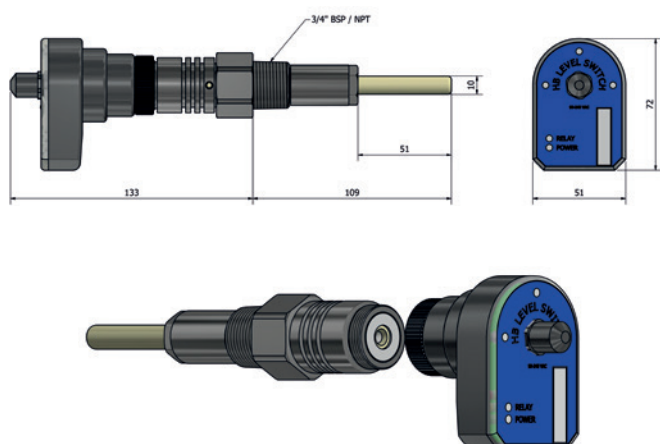

## Ordering codes

Output	Thread type	Ordering code
Solid state relay - NO	3/4" NPT	HBSR-U-SSR2/NO-2
Solid state relay - NO	3/4" BSPP	HBSR-U-SSR2/NO-6
Solid state relay - NC	3/4" NPT	HBSR-U-SSR2/NC-2
Solid state relay - NC	3/4" BSPP	HBSR-U-SSR2/NC-6

## Spare parts for HBSR-U-SSR2

Position	Specification	Type	Ordering code
1	Electronic parts	NO	HBSR-U-SSR2/NO-EL
		NC	HBSR-U-SSR2/NC-EL
2	Mechanical parts	3/4" NPT	HBSR-U-MEK-2
		3/4" BSPP	HBSR-U-MEK-6

## Spare parts for HBSR-HFC-SSR-2

Position	Specification	Type	Ordering code
1	Electronic parts	NO	HBSR-HFC-SSR-2/NO-EL
		NC	HBSR-HFC-SSR-2/NC-EL

# HFC Liquid Level Switch - Low Temperature

Category: HBSR-SSR-1/IP

Designed for the industrial refrigeration industry - max pressure up to 100 bar.

5 m cable included.

Split design that makes it possible to mount and perform a diagnostic without emptying the tanks for refrigerant.

Clear LED indication at level detection.

Reliable design with electronic solid state output and contact function NO or NC.



## Functional description

HBSR-SSR-1/IP Refrigerant Switch with built-in heater to protect against condensation at low temperatures. The switch is suited for use in freezers and for outdoor applications. It will typically be used for control of refrigerant liquid supply to separators. It is also used to control drainage of the liquid refrigerant during hot gas defrost.

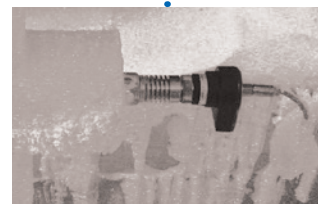
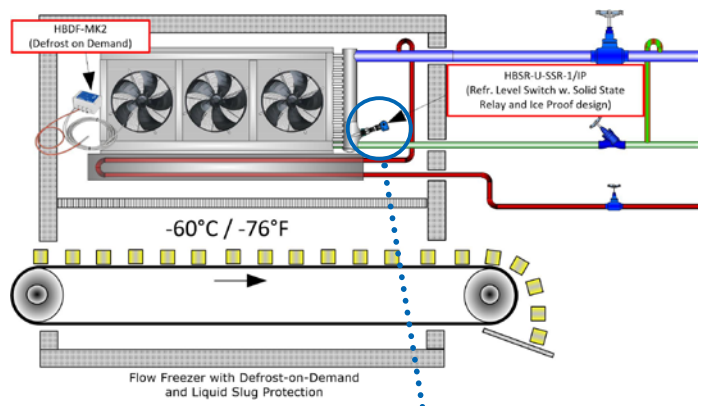

## Technical data

Power supply		Mechanical specifications	
Supply	24 V DC $\pm 10\%$	Thread connection	3/4" NPT
Current consumption - sensor only*	Max 600 mA	Material - mechanical parts	AISI 304 / PTFE
Plug connection	M12 - DIN 0627	Material - electronic parts	Nylon 6 (PA)
Output		Dimensions	
Permitted load on potential free contactless set	1A (24V DC)	Environmental conditions	
Output function	NC or NO	Ambient temperature	-60...50°C
LED indication	Green, yellow, and red	Refrigerant temperature	-60...+80°C
Cable specification (power supply)		Max pressure	100 bar
Cable size	5 m - 3 x 0.25 mm <sup>2</sup>	Protection degree	IP66
Cable glands	PG7 / M8	Vibrations	IEC 68-2-6 (4g)
Cable resistance	500 $\Omega$ /Km		
Approvals			
CE	EN 61000-2		

## Mechanical dimensions

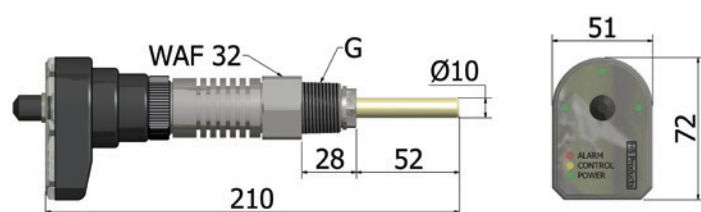

## Ordering codes

Output	Thread type	Ordering code
NC	3/4" NPT	HBSR-SSR-1/IP-NC-2
NO	3/4" NPT	HBSR-SSR-1/IP-NO-2
NC	3/4" BSPP	HBSR-SSR-1/IP-NC-6
NO	3/4" BSPP	HBSR-SSR-1/IP-NO-6
NC	1" BSPP	HBSR-SSR-1/IP-NC-8
NO	1" BSPP	HBSR-SSR-1/IP-NO-8

## Spare parts

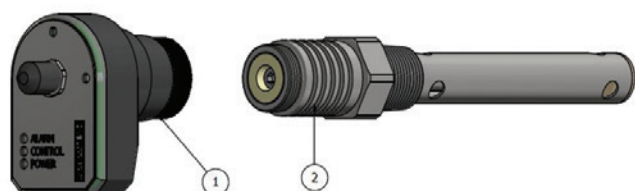

Position	Specification	Type	Ordering code
1	Electronic parts	PC-programmable / NC	HBSR-SSR-1/NC/IP-EL
		PC-programmable / NO	HBSR-SSR-1/NC/IP-EL
2	Mechanical parts	3/4" NPT thread	HBSR-MEK-IP-2
		3/4" BSPP thread	HBSR-MEK-IP-6
		1" BSPP thread	HBSR-MEK-IP-8

# Compressor Protection

Category: HBCP & HBX



HBCP Compressor Protection (rod style)



HBX Sensor in strainer housing (for compressor protection)

## Functional description

HBCP is variant of the HBX vapor quality sensor used at the compressor inlet. HBCP can provide an alarm, when the liquid content in the gas pass the critical set point or simply supply an analog signal to a PLC. The sensor can prevent liquid refrigerant from entering the compressor, causing damage to the moving parts. The sensor has a high sensitivity and detects even small liquid droplets before they become critical to the compressor. The sensor has a uniquely short reaction time which can be used for emergency stop of the compressor, but typically the signal can be used as an early warning or as a part of the evaporator control.

Two types are available: The rod style sensor, which is installed in a pipe elbow or the strainer house version. The strainer house solution is easier to install correctly.

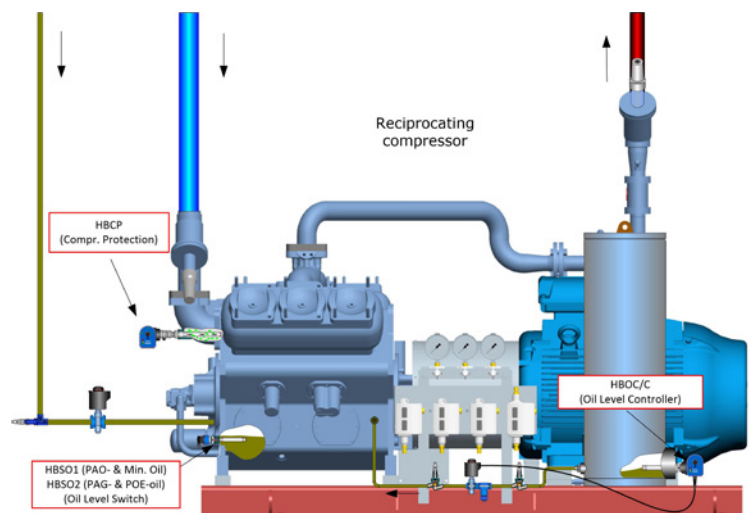

## Technical data for HBCP

Power supply		Mechanical specifications	
Voltage	24 V DC + 10%	Thread connection	¾"/1" NPT or BSPP
Current consumption - sensor only*	Max 600 mA	Material – mechanical parts	AISI 304 / PTFE
Plug connection	M12, 5 pins - DIN 0627	Material – electronic parts	Nylon 6 (PA)
Output		Dimensions	
Output type	PNP-1 A	Environmental conditions	See drawing
Output function	NC or NO	Ambient temperature	-30...+50°C
LED indication	Alarm, warning, power	Refrigerant temperature*	-60...+80°C
Cable specification (power supply)		Max pressure	100 bar
Cable size	5 m - 3 x 0.25 mm <sup>2</sup>	Protection degree	IP65
Cable glands	PG7 / M8	Vibrations	IEC 68-2-6 (4g)
Cable resistance**	500 Ω/Km		
Approvals			
CE	EN 61000-2		
Configuration			
Type of configuration	HB Tool		
Tool to be used	HBCP software		

\* Total consumption is sensor consumption plus output and it depends on ambient temperature.

## Mechanical dimensions for HBCP

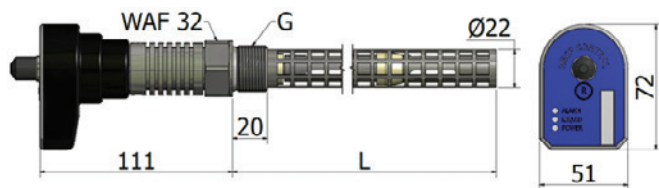

## Ordering codes for HBCP

Pipe size (compressor line)	Length (L)	Connection	Ordering code
< 2"	150 mm	¾" NPT	HBCP-1.5-2
< 2"	150 mm	¾" BSPP	HBCP-1.5-6
< 2"	300 mm	¾" NPT	HBCP-3-2
< 2"	300 mm	¾" BSPP	HBCP-3-6
> 2"	300 mm	1" NPT	HBCP-3-9
> 2"	300 mm	1" BSPP	HBCP-3-8

## Spare parts for HBCP

Position	Specification	Type	Ordering code
1	Electronic part	PC-programmable	HBCP-EL
2	Mechanical parts	¾" NPT	HBCP-MEK-1.5-2
		¾" BSPP	HBCP-MEK-1.5-6
		¾" NPT	HBCP-MEK-3-2
		¾" BSPP	HBCP-MEK-3-6
		1" BSPP	HBCP-MEK-3-8
		1" NPT	HBCP-MEK-3-9

## HBX Compressor Protection in Strainer Housing

To help you install the Compressor Protection Sensor correctly we recommend using an HBX Sensor in strainer housing.

For technical data, mechanical dimensions and ordering codes for the strainer house solution please go to [page 23](#).

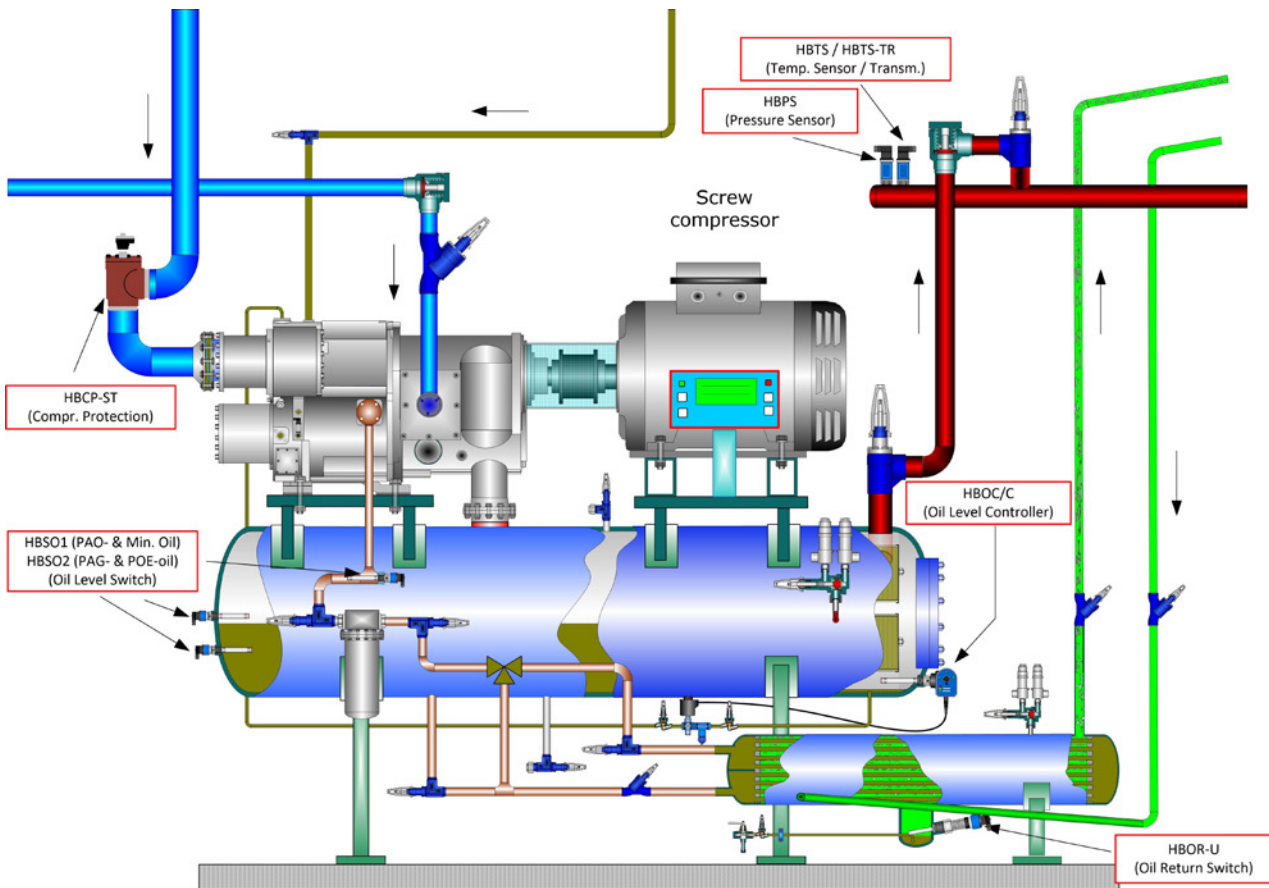

# HFC Liquid Level Sensor - Wire

Category: HBLT-W-WIRE & HBSLT-W-WIRE

Flexible sensor wire, which is adjustable to a length of 600 to 4000 mm (6000 mm).

Simple calibration for the specified length.

5 m cable included.

Alarm output can be set in a range from 10% to 100%.

3 digits display showing level in percentage.

Can be used for marine applications, since measurement is not affected by contact with the metal surface of the overflow pipe.

Measures HFC refrigerants (R22, R134A, R404A, R410A, R507, R717 & R718).

## Functional description:

HBLT-wire is a capacitive sensor for level measurement of NH3 refrigerant in industrial refrigeration systems. The sensor has an output signal of 4-20 mA, which is proportional with 0 to 100%. The output signal is 4 mA for an empty vessel and 20 mA for a full vessel. HBLT-wire can be adjusted in length to the current application. The sensor element consists of a 2 mm preisolated steel wire. Both parts are provided with a length of 4 m and can be shortened with diagonal cutters or other pliers. HBLT-wire can be used in connection with the HBLT-C1 controller for controlling pumps, etc., or it can be configured to directly control a valve without the need for another controller. Also available with integrated cable for direct control of any type of liquid valve.

The sensor is delivered in a version without integrated cable (named HBLT-Wire) and a version with cable for direct control of valves (named HBSLT-Wire).



- Available as 2-wire sensor
- Now with ATEX / IECEx certificate (This version is without LED display)

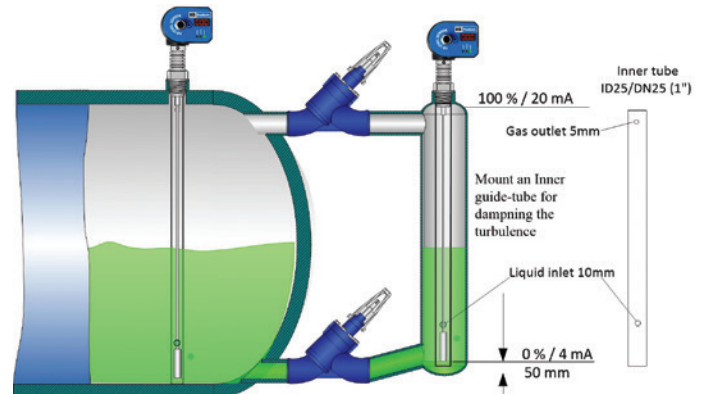

## Use of HBLT-Wire sensor

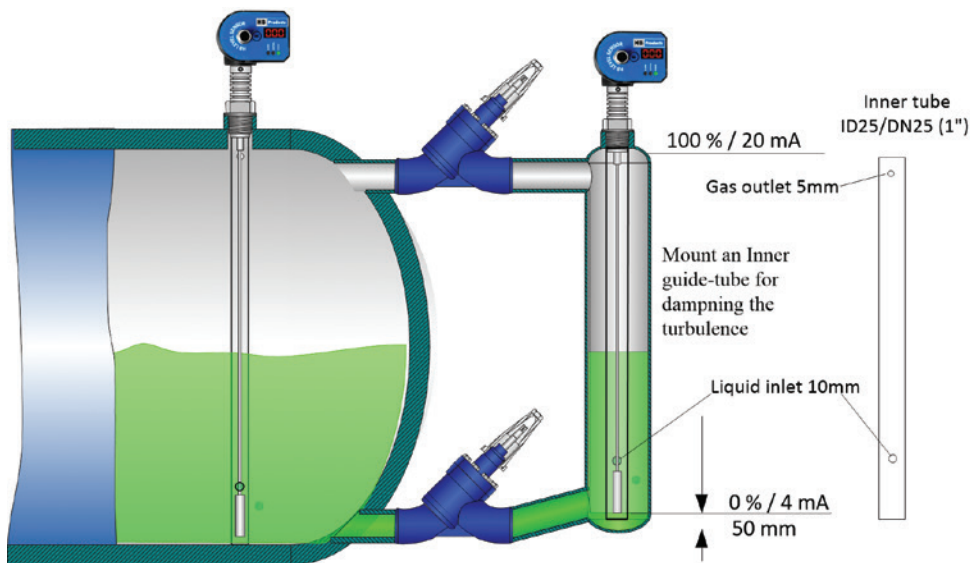

When using a level sensor for measuring Ammonia in a compact plate and shell heat exchanger or other systems with turbulent conditions, we have new recommendation based on recent experience:

### For Stand-pipes with stable conditions (smooth changes in the level):

- Use a HBLT-Wire or a HBLT-A1 rod-style sensor.

### For Stand-pipes with turbulent conditions (a lot of turbulence, cooking, foaming, liquid from the top):

- Use a HBLT-A1 rod-style sensor, or
- Use only a HBLT-Wire sensor when you have it mounted in an inner guide-tube of e.g. DN25 as illustrated. The guide-tube will dampen the turbulence and the foaming and you will have a good measurement.
- If HBLT-Wire sensor is already mounted under these conditions WITHOUT a guide-tube, do eventually set the filter time function between 60-120 seconds to dampen the signal from the turbulent conditions.

### For tank/drum installation:

- Use a HBLT-A1 rod-style sensor, or
- Use only a HBLT-Wire sensor when you have it mounted in an inner guide-tube of e.g. DN25 as illustrated. The guide-tube will dampen the level and the foaming and you will have a good measurement.
- If HBLT-Wire sensor is already mounted under these conditions WITHOUT a guide-tube, do eventually set the filter time function between 60-120 seconds to dampen the signal from the turbulent conditions.

### For Alfa Laval U-turn evaporator:

- Use a HBLT-A1 rod-style sensor.



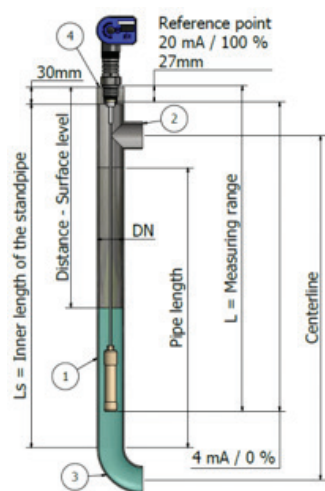

Stand pipe: DN32.....DN65.  
Recommended pipe standard: DIN 10220  
Recommended bending: DIN 2615-1/Type 3  
Recommended TEE: DIN 2615-1

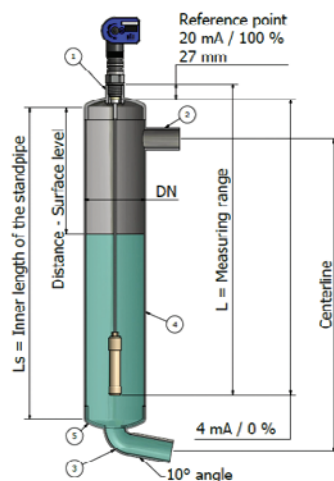

Standpipe: DN65...DN100.  
Recommended pipe standard: DIN 10220  
Recommended bending: DIN 2615-1/  
Type 3  
Site pipe can be designed in smaller pipe  
e.g. 0.5 x DN.

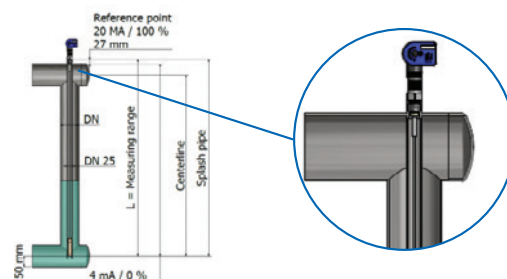

If the sensor is installed in standpipe on front of plate heat exchanger with return liquid flow the wire must be protected against splashing with a protection tube size DN25..DN32.

If a splashing pipe is not installed, the filter time can be changed to 120 sec. See separate manual for sensor configuration.

## Technical data

Power supply		Mechanical specifications	
Supply	24 V AC/DC + 10%	Thread connection	3/4" NPT/BSPP
Current consumption - sensor only*	Max 50 mA	Material - mechanical parts	AISI 304 / PTFE
Plug connection	M12, 5 pins - DIN 0627	Material - electronic parts	Nylon 6 (PA)
		Dimensions	See drawing
Output		Environmental conditions	
Analog output	4-20 mA	Ambient temperature	-30...+50°C
Permitted load on potential free contactless set.	1A (24V DC)	Refrigerant temperature	-60...+80°C
LED indication	3 digits display	Max pressure	100 bar
Max. possible resistance	500 ohm	Protection degree	IP65
Cable specification (power supply)		Vibrations	IEC 68-2-6 (4g)
Cable size	5 m - 3 x 0.25 mm <sup>2</sup>	Accessories	(To be ordered separately)
Cable glands	PG7 / M8	Adapter - 3/4" NPT / 1" BSPP	HBS/ADAP/8/2
Cable resistance	500 Ω/Km	Adapter - 3/4" BSPP / 1" BSPP	HBS/ADAP/8/6
Approvals		Splitterbox	HBxC-Splitbox
CE	EN 61000-2	Adapter cable	HBxC-M12/DIN
EAC Regulation of Conformity			
Configuration			
Type of configuration	HB Tool		
Tool to be used	HBLT-Wire software		

\* Total consumption is sensor consumption plus output and it depends on ambient temperature.

## Mechanical dimensions

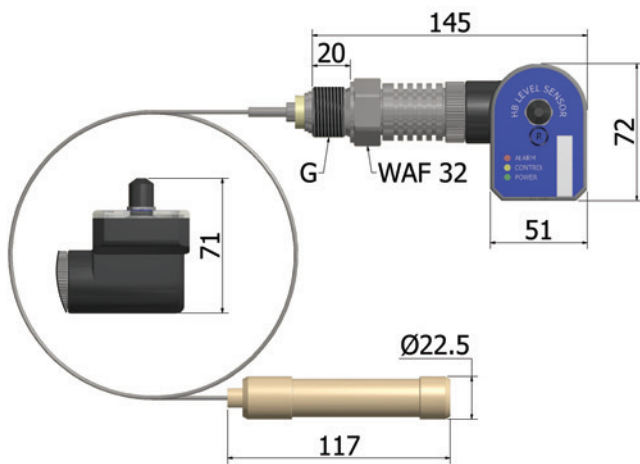

## Ordering codes

Length	Thread type	Without integrated cable	Modulating valve*	Stepper motor valve**	Pulse width modulation***
600 - 4000 mm	3/4" NPT	HBLT-W-WIRE-2	HBSLT-W-WIRE/C-2	HBSLT-W-WIRE/S-2	HBSLT-W-WIRE/PWM-2
600 - 4000 mm	3/4" BSPP	HBLT-W-WIRE-6	HBSLT-W-WIRE/C-6	HBSLT-W-WIRE/S-6	HBSLT-W-WIRE/PWM-6
600 - 6000 mm	3/4" NPT	HBLT-W-WIRE-6-2	HBSLT-W-WIRE/C-6-2	HBSLT-W-WIRE/S-6-2	HBSLT-W-WIRE/PWM-6-2
600 - 6000 mm	3/4" BSPP	HBLT-W-WIRE-6-6	HBSLT-W-WIRE/C-6-6	HBSLT-W-WIRE/S-6-6	HBSLT-W-WIRE/PWM-6-6
600 - 4000 mm	3/4" NPT	HBLT-W-WIRE-2-IP****			
600 - 4000 mm	3/4 BSPP	HBLT-W-WIRE-6-IP			

\*For direct control of a modulating valve such as Siemens MVS661.

\*\*For direct control of a stepper motor valve such as Carel.

\*\*\*For direct control of a pulse width modulation valve such as Danfoss AKVA.

\*\*\*\*HBLT-WIRE-IP is a low temperature version.

## Spare parts

Position	Specification	Type/Thread	Ordering code
1	Electronic parts	PC-programmable	HBLT-W-Wire-EL
		PC-programmable - for modulating valve	HBLT-W-WIRE/C-EL
		PC-programmable - for stepper motor	HBLT-W-WIRE/S-EL
		PC-programmable - for low temperature	HBLT-W-WIRE-EL-IP
2	Mechanical parts	3/4" NPT	HBLT-W-WIRE-MEK-2
		3/4" BSPP	HBLT-W-WIRE-MEK-6
3	Wire plumb	Dimensions: 22.5x115	HBLT-WIRE-PLUMB

# HFC Liquid Level Sensor - Flex

Category: HBLT-Flex & HBSLT-Flex - HFC / HFO / CO<sub>2</sub>

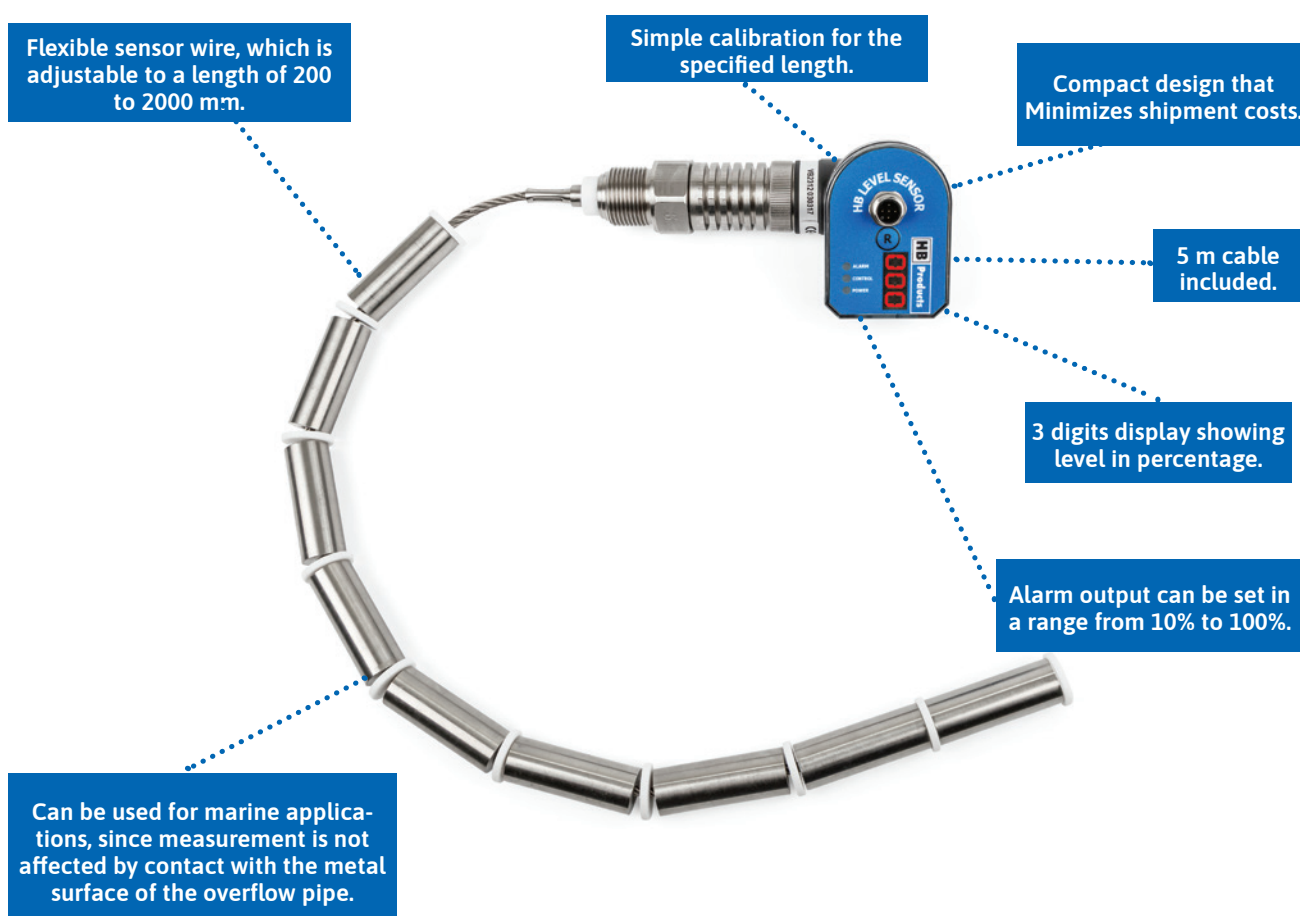

## Functional description:

HBLT-flex is a capacitive sensor for level measurement of HFC/HFO/CO<sub>2</sub> refrigerant in industrial refrigeration systems. The sensor has an output signal of 4-20 mA, which is proportional with 0 and 100%. Its output signal is 4 mA for an empty container and 20 mA for a full container. HBLT-flex can be adjusted in length to the current application. The sensor element consists of a 2 mm steel wire and 5 cm aluminum weights. Both parts are provided with a length of 4 m and can be shortened with diagonal cutters or other pliers. HBLT-flex can be used in connection with the HBLT-C1 controller for controlling pumps, etc., or it can be configured to directly control a valve without the need for another controller. The sensor is delivered in a version without integrated cable (named HBLT-Flex) and a version with cable for direct control of valves (named HBSLT-Flex).

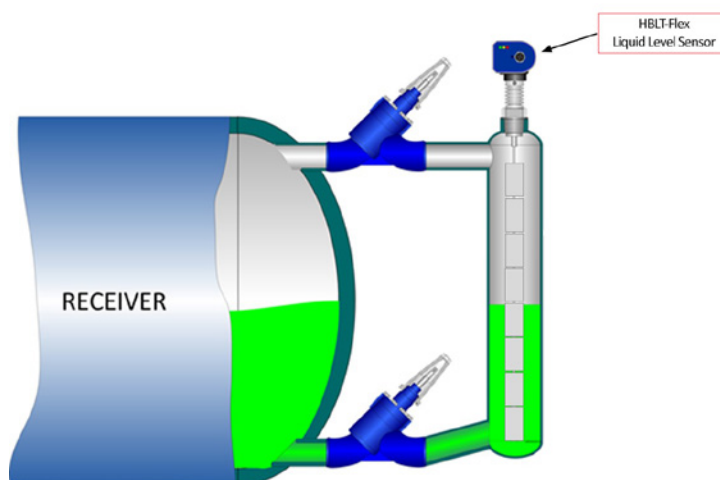

## Technical data

Power supply		Mechanical specifications	
Voltage	24 V AC/DC + 10%	Thread connection	3/4" NPT/BSPP
Current consumption - sensor only*	Max 30 mA	Material - mechanical parts	AISI 304 / PTFE
Plug connection	M12	Material - electronic parts	Nylon 6 (PA)
		Dimensions	See drawing
Output		Environmental conditions	
Analog output	4-20 mA	Ambient temperature	-30...+50°C
Alarm output	PNP, 1 A	Refrigerant temperature	-60...+60°C
LED indication	3 digits display	Max pressure	150 bar
Max. possible resistance	500 ohm	Protection degree	IP65
Cable specification (power supply)		Vibrations	IEC 68-2-6 (4g)
Cable size	5 m - 3 x 0.25 mm <sup>2</sup>	Accessories (To be ordered separately)	
Cable glands	PG7 / M8	Adapter - 3/4" NPT / 1" BSPP	HBS/ADAP/8/2
Cable resistance	500 Ω/Km	Adapter - 3/4" BSPP / 1" BSPP	HBS/ADAP/8/6
Approvals		Splitter box	HBxC-Splitbox
CE	EN 61000-2	Adapter cable	HBxC-M12/DIN
EAC Regulation of Conformity			
Configuration			
Type of configuration	HB Tool		
Tool to be used	HBLT-Wire software		

\* Total consumption is sensor consumption plus output and it depends on ambient temperature.

## Mechanical dimensions

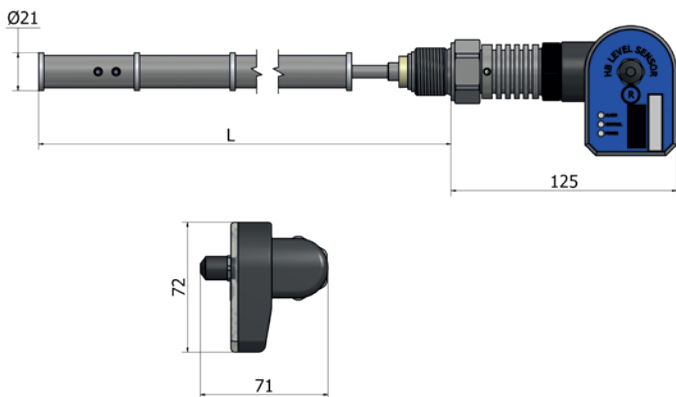

## Spare parts

Specification	Type/Thread	Ordering code
Electronic part	PC-programmable	HBLT-FLEX-EL

## Ordering codes

Length	Thread type	Without integrated cable	Modulating valve*	Stepper motor valve**	Without integrated cable***
200 mm	3/4" NPT	HBLT-FLEX-2-2	HBSLT-FLEX/C-2-2	HBSLT-FLEX/S-2-2	HBSLT-FLEX/PWM-2-2
200 mm	3/4" BSPP	HBLT-FLEX-2-6	HBSLT-FLEX/C-2-6	HBSLT-FLEX/S-2-6	HBSLT-FLEX/PWM-2-6
300 mm	3/4" NPT	HBLT-FLEX-3-2	HBSLT-FLEX/C-3-2	HBSLT-FLEX/S-3-2	HBSLT-FLEX/PWM-3-2
300 mm	3/4" BSPP	HBLT-FLEX-3-6	HBSLT-FLEX/C-3-6	HBSLT-FLEX/S-3-6	HBSLT-FLEX/PWM-3-6
400 mm	3/4" NPT	HBLT-FLEX-4-2	HBSLT-FLEX/C-4-2	HBSLT-FLEX/S-4-2	HBSLT-FLEX/PWM-4-2
400 mm	3/4" BSPP	HBLT-FLEX-4-6	HBSLT-FLEX/C-4-6	HBSLT-FLEX/S-4-6	HBSLT-FLEX/PWM-4-6
500 mm	3/4" NPT	HBLT-FLEX-5-2	HBSLT-FLEX/C-5-2	HBSLT-FLEX/S-5-2	HBSLT-FLEX/PWM-5-2
500 mm	3/4" BSPP	HBLT-FLEX-5-6	HBSLT-FLEX/C-5-6	HBSLT-FLEX/S-5-6	HBSLT-FLEX/PWM-5-6
600 mm	3/4" NPT	HBLT-FLEX-6-2	HBSLT-FLEX/C-6-2	HBSLT-FLEX/S-6-2	HBSLT-FLEX/PWM-6-2
600 mm	3/4" BSPP	HBLT-FLEX-6-6	HBSLT-FLEX/C-6-6	HBSLT-FLEX/S-6-6	HBSLT-FLEX/PWM-6-6
700 mm	3/4" NPT	HBLT-FLEX-7-2	HBSLT-FLEX/C-7-2	HBSLT-FLEX/S-7-2	HBSLT-FLEX/PWM-7-2
700 mm	3/4" BSPP	HBLT-FLEX-7-6	HBSLT-FLEX/C-7-6	HBSLT-FLEX/S-7-6	HBSLT-FLEX/PWM-7-6
800 mm	3/4" NPT	HBLT-FLEX-8-2	HBSLT-FLEX/C-8-2	HBSLT-FLEX/S-8-2	HBSLT-FLEX/PWM-8-2
800 mm	3/4" BSPP	HBLT-FLEX-8-6	HBSLT-FLEX/C-8-6	HBSLT-FLEX/S-8-6	HBSLT-FLEX/PWM-8-6
900 mm	3/4" NPT	HBLT-FLEX-9-2	HBSLT-FLEX/C-9-2	HBSLT-FLEX/S-9-2	HBSLT-FLEX/PWM-9-2
900 mm	3/4" BSPP	HBLT-FLEX-9-6	HBSLT-FLEX/C-9-6	HBSLT-FLEX/S-9-6	HBSLT-FLEX/PWM-9-6
1200 mm	3/4" NPT	HBLT-FLEX-12-2	HBSLT-FLEX/C-12-2	HBSLT-FLEX/S-12-2	HBSLT-FLEX/PWM-12-2
1200 mm	3/4" BSPP	HBLT-FLEX-12-6	HBSLT-FLEX/C-12-6	HBSLT-FLEX/S-12-6	HBSLT-FLEX/PWM-12-6
1400 mm	3/4" NPT	HBLT-FLEX-14-2	HBSLT-FLEX/C-14-2	HBSLT-FLEX/S-14-2	HBSLT-FLEX/PWM-14-2
1400 mm	3/4" BSPP	HBLT-FLEX-14-6	HBSLT-FLEX/C-14-6	HBSLT-FLEX/S-14-6	HBSLT-FLEX/PWM-14-6
1600 mm	3/4" NPT	HBLT-FLEX-16-2	HBSLT-FLEX/C-16-2	HBSLT-FLEX/S-16-2	HBSLT-FLEX/PWM-16-2
1600 mm	3/4" BSPP	HBLT-FLEX-16-6	HBSLT-FLEX/C-16-6	HBSLT-FLEX/S-16-6	HBSLT-FLEX/PWM-16-6
1800 mm	3/4" NPT	HBLT-FLEX-18-2	HBSLT-FLEX/C-18-2	HBSLT-FLEX/S-18-2	HBSLT-FLEX/PWM-18-2
1800 mm	3/4" BSPP	HBLT-FLEX-18-6	HBSLT-FLEX/C-18-6	HBSLT-FLEX/S-18-6	HBSLT-FLEX/PWM-18-6
2000 mm	3/4" NPT	HBLT-FLEX-20-2	HBSLT-FLEX/C-20-2	HBSLT-FLEX/S-20-2	HBSLT-FLEX/PWM-20-2
2000 mm	3/4" BSPP	HBLT-FLEX-20-6	HBSLT-FLEX/C-20-6	HBSLT-FLEX/S-20-6	HBSLT-FLEX/PWM-20-6

\*For direct control of a modulating valve such as Siemens MVS661.

\*\*For direct control of a stepper motor valve such as Carel.

\*\*\*For direct control of a pulse width modulation valve such as Danfoss AKVA.

# HFC Liquid Level Sensor

## Category: HBLC-HFC & HBSLC-HFC

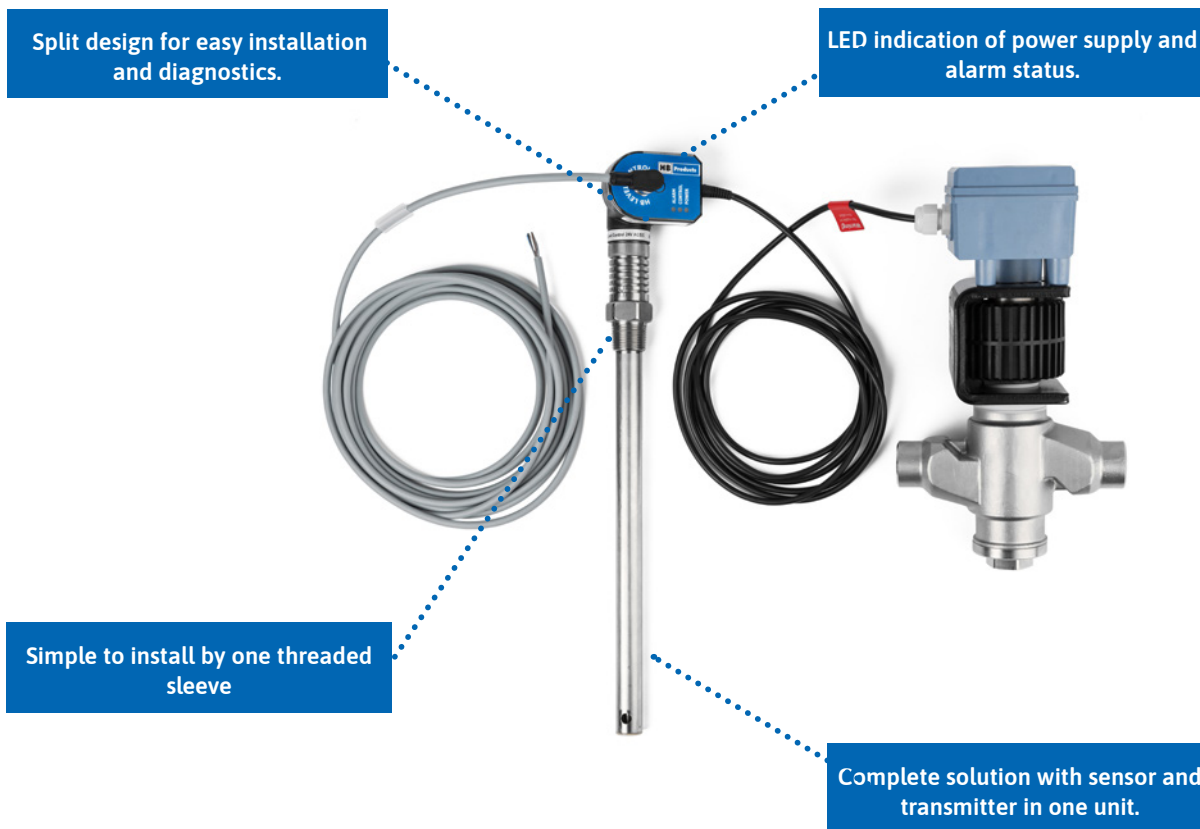

- Available as 2-wire sensor
- Now with ATEX / IECEx certificate (This version is without LED display)

### Functional description:

HBLC-HFC is an intelligent sensor with a built-in microprocessor. It is designed for continuous level measurement of liquid HFC refrigerant in refrigeration systems.

HBLC-HFC is designed for the measurement of HFC refrigerant level in chillers, evaporators and condensers. The sensor is pre-configured to R134, but can be configured for other HFC types.

The sensor emits a 4-20mA analog signal, which is proportional to the liquid level. The construction of the sensor makes it suitable for systems with pressure of up to 150 bar.

The sensor is delivered in a version without integrated cable (named HBLC) and a version with cable for direct control of valves (named HBSLC).

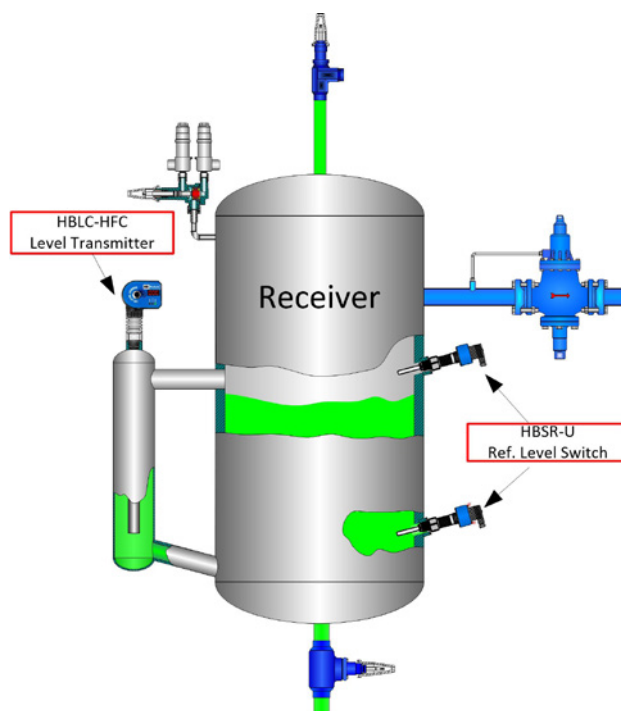

## HBLC-HFC on receiver

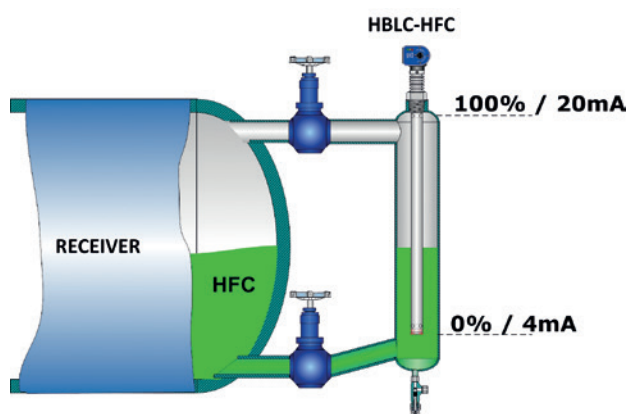

## Technical data - sensor

Supply		Mechanical Specifications	
Supply:	24 V AC/DC $\pm 10\%$ *	Thread connection	$\frac{3}{4}$ " NPT & BSPP
Current consumption - sensor only*	Max 50 mA	Materials - mechanical parts:	AISI304/PTFE
Plug	M12, 5 pins - DIN 0627	Materials - electronic parts:	Nylon 6 (PA)
		Dimensions	See drawing
Output			
Analog output	4-20 mA	Ambient temperature	-30...+50°C
Permitted load on potential free contactless set	1A (24V DC)	Refrigerant temperature	-60...+80°C
LED indication	Green, yellow, and red	Max. operational pressure:	150 bar
Cable specification		Protection degree	IP65
Supply cable, 5 meters	HBxC-M12/5	Vibrations	IEC 68-2-6 (4g)
Cable size	PUR - 5 x 0,34 mm <sup>2</sup>		
Approvals			
EMC Emission:	EN61000-3-2		
EMC Immunity:	EN61000-4-2		

\* Total consumption is sensor consumption plus output and it depends on ambient temperature.

## Mechanical dimensions

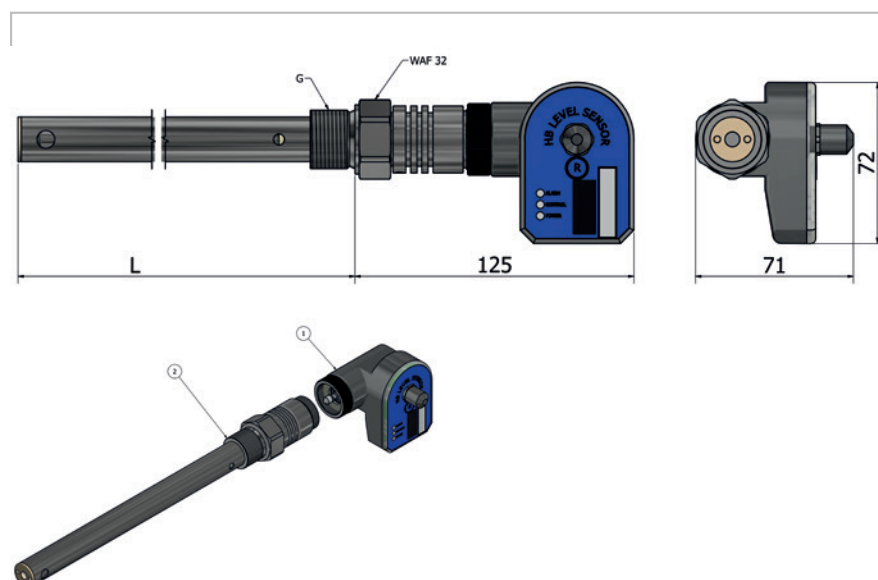

## Ordering codes

Length	Length/Thread	Without integrat- ed cable	Modulating valve*	Stepper motor valve**	Pulse width modula- tion***
200 mm	3/4" NPT	HBLC-HFC-2-2	HSBLC-HFC-2-2	HSBLC-HFC/C-2-2	HSBLC-HFC/PWM-2-2
200 mm	3/4" BSPP	HBLC-HFC-2-6	HSBLC-HFC-2-6	HSBLC-HFC/C-2-6	HSBLC-HFC/PWM-2-6
300 mm	3/4" NPT	HBLC-HFC-3-2	HSBLC-HFC-3-2	HSBLC-HFC/C-3-2	HSBLC-HFC/PWM-3-2
300 mm	3/4" BSPP	HBLC-HFC-3-6	HSBLC-HFC-3-6	HSBLC-HFC/C-3-6	HSBLC-HFC/PWM-3-6
400 mm	3/4" NPT	HBLC-HFC-4-2	HSBLC-HFC-4-2	HSBLC-HFC/C-4-2	HSBLC-HFC/PWM-4-2
400 mm	3/4" BSPP	HBLC-HFC-4-6	HSBLC-HFC-4-6	HSBLC-HFC/C-4-6	HSBLC-HFC/PWM-4-6
500 mm	3/4" NPT	HBLC-HFC-5-2	HSBLC-HFC-5-2	HSBLC-HFC/C-5-2	HSBLC-HFC/PWM-5-2
500 mm	3/4" BSPP	HBLC-HFC-5-6	HSBLC-HFC-5-6	HSBLC-HFC/C-5-6	HSBLC-HFC/PWM-5-6
600 mm	3/4" NPT	HBLC-HFC-6-2	HSBLC-HFC-6-2	HSBLC-HFC/C-6-2	HSBLC-HFC/PWM-6-2
600 mm	3/4" BSPP	HBLC-HFC-6-6	HSBLC-HFC-6-6	HSBLC-HFC/C-6-6	HSBLC-HFC/PWM-6-6
700 mm	3/4" NPT	HBLC-HFC-7-2	HSBLC-HFC-7-2	HSBLC-HFC/C-7-2	HSBLC-HFC/PWM-7-2
700 mm	3/4" BSPP	HBLC-HFC-7-6	HSBLC-HFC-7-6	HSBLC-HFC/C-7-6	HSBLC-HFC/PWM-7-6
800 mm	3/4" NPT	HBLC-HFC-8-2	HSBLC-HFC-8-2	HSBLC-HFC/C-8-2	HSBLC-HFC/PWM-8-2
800 mm	3/4" BSPP	HBLC-HFC-8-6	HSBLC-HFC-8-6	HSBLC-HFC/C-8-6	HSBLC-HFC/PWM-8-6
900 mm	3/4" NPT	HBLC-HFC-9-2	HSBLC-HFC-9-2	HSBLC-HFC/C-9-2	HSBLC-HFC/PWM-9-2
900 mm	3/4" BSPP	HBLC-HFC-9-6	HSBLC-HFC-9-6	HSBLC-HFC/C-9-6	HSBLC-HFC/PWM-9-6
1000 mm	3/4" NPT	HBLC-HFC-10-2	HSBLC-HFC-10-2	HSBLC-HFC/C-10-2	HSBLC-HFC/PWM-10-2
1000 mm	3/4" BSPP	HBLC-HFC-10-6	HSBLC-HFC-10-6	HSBLC-HFC/C-10-6	HSBLC-HFC/PWM-10-6
1100 mm	3/4" NPT	HBLC-HFC-11-2	HSBLC-HFC-11-2	HSBLC-HFC/C-11-2	HSBLC-HFC/PWM-11-2
1100 mm	3/4" BSPP	HBLC-HFC-11-6	HSBLC-HFC-11-6	HSBLC-HFC/C-11-6	HSBLC-HFC/PWM-11-6
1200 mm	3/4" NPT	HBLC-HFC-12-2	HSBLC-HFC-12-2	HSBLC-HFC/C-12-2	HSBLC-HFC/PWM-12-2
1200 mm	3/4" BSPP	HBLC-HFC-12-6	HSBLC-HFC-12-6	HSBLC-HFC/C-12-6	HSBLC-HFC/PWM-12-6
1300 mm	3/4" NPT	HBLC-HFC-13-2	HSBLC-HFC-13-2	HSBLC-HFC/C-13-2	HSBLC-HFC/PWM-13-2
1300 mm	3/4" BSPP	HBLC-HFC-13-6	HSBLC-HFC-13-6	HSBLC-HFC/C-13-6	HSBLC-HFC/PWM-13-6
1400 mm	3/4" NPT	HBLC-HFC-14-2	HSBLC-HFC-14-2	HSBLC-HFC/C-14-2	HSBLC-HFC/PWM-14-2
1400 mm	3/4" BSPP	HBLC-HFC-14-6	HSBLC-HFC-14-6	HSBLC-HFC/C-14-6	HSBLC-HFC/PWM-14-6
1500 mm	3/4" NPT	HBLC-HFC-15-2	HSBLC-HFC-15-2	HSBLC-HFC/C-15-2	HSBLC-HFC/PWM-15-2
1500 mm	3/4" BSPP	HBLC-HFC-15-6	HSBLC-HFC-15-6	HSBLC-HFC/C-15-6	HSBLC-HFC/PWM-15-6
1700 mm	3/4" NPT	HBLC-HFC-17-2	HSBLC-HFC-17-2	HSBLC-HFC/C-17-2	HSBLC-HFC/PWM-17-2
1700 mm	3/4" BSPP	HBLC-HFC-17-6	HSBLC-HFC-17-6	HSBLC-HFC/C-17-6	HSBLC-HFC/PWM-17-6
2000 mm	3/4" NPT	HBLC-HFC-20-2	HSBLC-HFC-20-2	HSBLC-HFC/C-20-2	HSBLC-HFC/PWM-20-2
2000 mm	3/4" BSPP	HBLC-HFC-20-6	HSBLC-HFC-20-6	HSBLC-HFC/C-20-6	HSBLC-HFC/PWM-20-6
2500 mm	3/4" NPT	HBLC-HFC-25-2	HSBLC-HFC-25-2	HSBLC-HFC/C-25-2	HSBLC-HFC/PWM-25-2
2500 mm	3/4" BSPP	HBLC-HFC-25-6	HSBLC-HFC-25-6	HSBLC-HFC/C-25-6	HSBLC-HFC/PWM-25-6
3000 mm	3/4" NPT	HBLC-HFC-30-2	HSBLC-HFC-30-2	HSBLC-HFC/C-30-2	HSBLC-HFC/PWM-30-2
3000 mm	3/4" BSPP	HBLC-HFC-30-6	HSBLC-HFC-30-6	HSBLC-HFC/C-30-6	HSBLC-HFC/PWM-30-6

## Spare parts

Position	Specification	Type	Ordering code
1	Mechanical parts	Mechanical part for HBLC-HFC	HBLC-HFC-XXX-MEK*
2	Electronic part	Electronic part for HBLC-HFC - With LED	HBLC-HFC-EL-LED*

\*When ordering mechanical parts please inform about length- and thread type.

\*Electronic part must be calibrated on-site



# Level Controller

Category: HBLT-C1 & HBMD-L



HBLT-C1



HBMD



## Functional description:

HBLT-C1 is designed for level control in vessels in industrial refrigeration systems. It can be used in connection with the HBLT-A1 and HBLT-Wire analog level sensor or other similar sensors with a 4-20 mA output signal. To be used in:

- Pump vessels
- Separators
- Intercoolers
- Economizers
- Condensers
- Receivers

HBMD-L is a display for showing the level value directly like the display on the level sensor. The display can be installed anywhere on the cable between a level sensor and the PLC using M12 cables.

The sensor is supplied with a 5 m M12 extension cable.

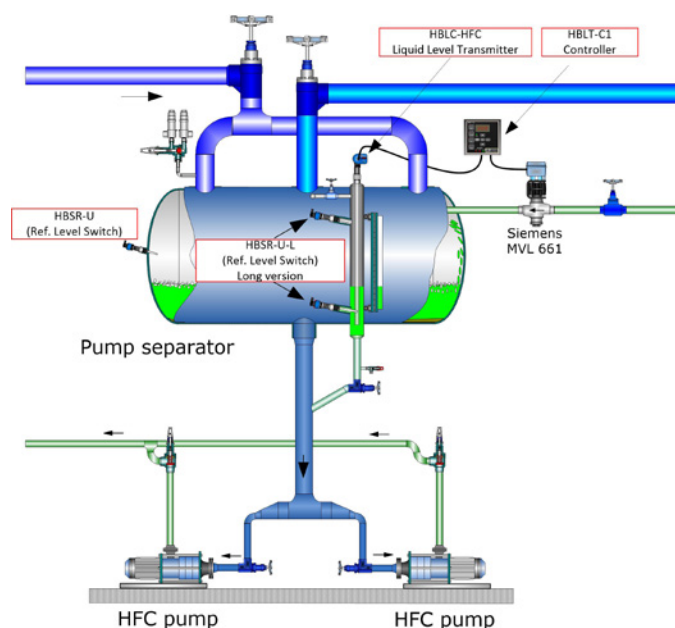

## Technical data

Supply	HBLT-C1	HBLT-C1-ENC	HBMD-L
Voltage	24 V AC/DC $\pm$ 10 %	100..240 V AC or 24 V AC/DC	24 V AC/DC $\pm$ 10 %
Frequency	50/60 Hz	50/60 Hz	50/60 Hz
Current consumption	Max 40 mA	Max 1.5 A	Max 40 mA
Connection	Screw terminal	Screw terminal	Plug
Wire size	< 2.5 mm <sup>2</sup>	< 2.5 mm <sup>2</sup>	< 2.5 mm <sup>2</sup>
<b>Installation conditions:</b>			
Surrounding temperature	-20...+70°C	-20...+70°C	-40...+70°C
Protection class	IP45	IP65	IP65
Relative humidity	20...80 %	20...80 %	20...80 %
<b>Approvals:</b>			
EMC Emission	EN61000-3-2	EN61000-3-2	EN61000-3-2
EMC Immunity	EN61000-4-2	EN61000-4-2	EN61000-4-2
<b>Mechanical specifications:</b>			
Mounting	In front of panel	In cabinet/casing for mounting on a wall	Wall mounting
External measurement	(96x96x94 (WxHxD))	298x198x182 mm (WxHxD)	100x81x40 mm (WxHxD)
Cut-out measurement	92.8x92.8 mm	N.A.	N/A
Material	Plastic	Plastic	Plastic
Weight	0.2 kg	1.4 kg	0.3 kg
<b>Display:</b>			
Digit's display	3 digits, red	3 digits, red	3 digits, red
Alarm indication	LED (green og red)	LED (green og red)	N/A
Programming	From front	From front	HB Tool
Updating	1 time each second	1 time each second	1 time each second
<b>Input:</b>			
Analog input - sensor	4-20 mA	4-20 mA	4-20 mA
<b>Output:</b>			
Analog output	4-20 mA	4-20 mA	4-20 mA
Load	3A/24 VDC	3A/24 VDC	3A/24 VDC
Relay output	@24VAC/VDC: 3 x 3A @110 V AC: 3 x 5A @220 V AC: 3 x 5A	@24VAC/VDC: 3 x 3A @110 V AC: 3 x 5A @220 V AC: 3 x 5A	@24VAC/VDC: 3 x 3A @110 V AC: 3 x 5A @220 V AC: 3 x 5A

## Ordering codes

Cabinet design	Ordering code
Controller - 24 V AC/DC power supply	HBLT-C1
Controller build in a cabinet & mounted with 110/240 V power supply	HBLT-C1-ENC

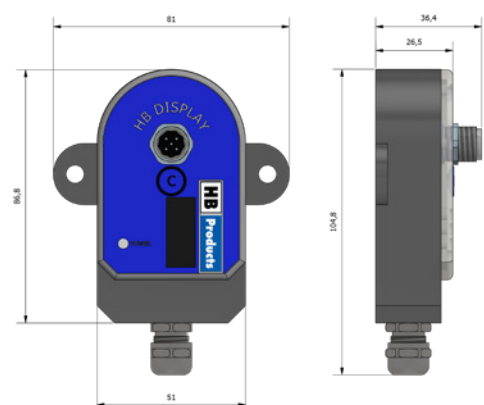

# F-gas Level Sensor

Category: HBLC-Fgas / HBLC-Fgas-LED



## Functional description:

HBLC-Fgas is complying with the global HFC phasedown and the F-gas regulations

HBLC-Fgas-xxx\* is a new range of level sensors for HFC applications making it possible to comply with the strict F-gas regulations. The sensor is available in several lengths and available with simple 4-20 mA output signal as well as a more advanced version with 3 digit LED display. Made for easy installation directly in receivers.

By using this sensor you will be able to add to the level of safety in your entire application as it not only senses the actual level but as well gives an alarm output (PNP NO/NC)



HBLC-Fgas-LED sensor with digital display mounted on vertical liquid receiver

### Technical data – HBLC-Fgas Level Sensor

Power supply		Mechanical Specifications	
Supply	24 V AC/DC ±10%	Thread connection	¾" NPT
Current consumption - sensor only*	200 mA	Materials - mechanical parts:	AISI304/PTFE
Plug	DIN 43 650 MV PLUG	Materials - electronic parts:	Nylon 6 (PA)
		Dimensions	See drawing
		<b>Installation conditions:</b>	
Output		Ambient temperature	-30...+50°C
Analog output	4-20 mA	Refrigerant temperature	-60...+80°C
LED indication	Green	Max. operational pressure:	100 bar
		Protection degree	IP67
		Vibrations	IEC 68-2-6 (4g)
Approvals			
EMC Emission:	EN61000-3-2		
EMC Immunity:	EN61000-4-2		

\* Total consumption is sensor consumption plus output and it depends on ambient temperature.

### Technical data – HBLC-Fgas-LED Level Sensor

Supply		Mechanical Specifications	
Supply:	24 V AC/DC ±10%	Thread connection	¾" NPT
Current consumption - sensor only	Max 50 mA	Materials - mechanical parts:	AISI 304 / PTFE
Plug	M12, 5 pins - DIN 0627	Materials - electronic parts:	Nylon 6 (PA)
		Housing design	Angle
		Dimensions	See drawing
		<b>Installation conditions:</b>	
Output		Ambient temperature	-30...+50°C
Analog output	4-20 mA	Refrigerant temperature	-60...+80°C
Alarm output	1A (24V DC)	Max. operational pressure:	100 bar
LED indication	Green, yellow, and red	Protection degree	IP65
Cable specification		Vibrations	IEC 68-2-6 (4g)
Supply cable, 5 meters	HBxC-M12/5		
Cable size	PUR - 5 x 0,34 mm2		
Approvals			
EMC Emission:	EN61000-3-2		
EMC Immunity:	EN61000-4-2		

## Mechanical dimensions

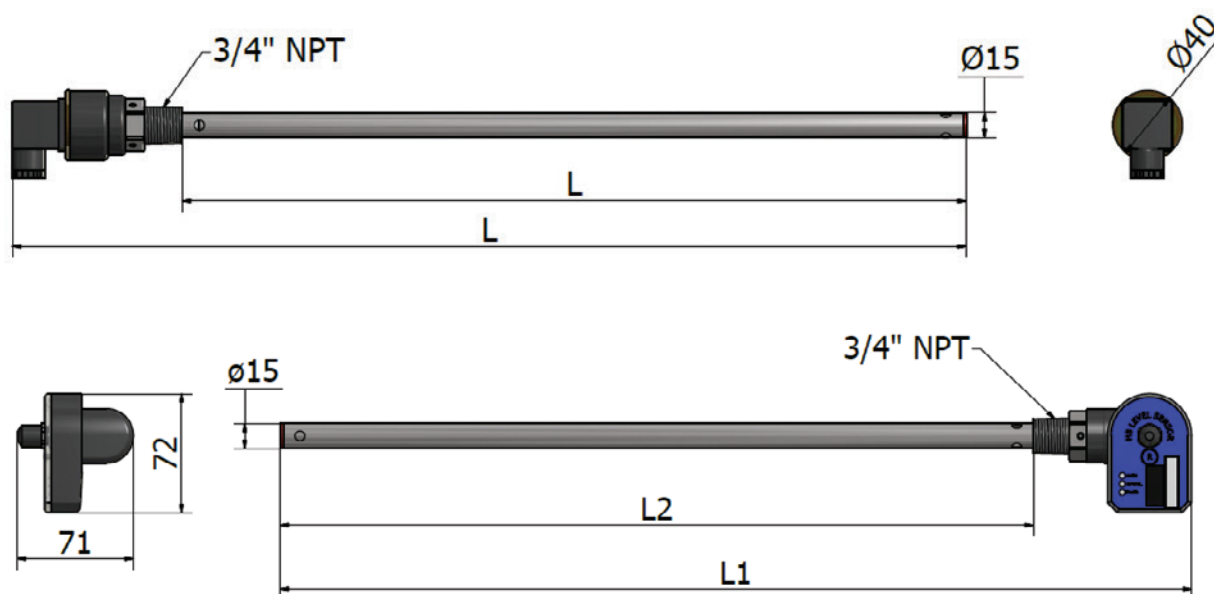

## Ordering codes

Length	Thread type	Ordering codes
260 mm	1/2" NPT	HBLC-Fgas-2.6-1
315 mm	1/2" NPT	HBLC-Fgas-3.2-1
441 mm	1/2" NPT	HBLC-Fgas-4.4-1
566 mm	1/2" NPT	HBLC-Fgas-5.7-1
602 mm	1/2" NPT	HBLC-Fgas-6-1
762 mm	1/2" NPT	HBLC-Fgas-7.6-1
816 mm	1/2" NPT	HBLC-Fgas-8.2-1
882 mm	1/2" NPT	HBLC-Fgas-8.9-1
1152 mm	1/2" NPT	HBLC-Fgas-11.5-1
1640 mm	1/2" NPT	HBLC-Fgas-16.4-1
260 mm	1/2" NPT	HBLC-Fgas-2.6-1-LED*
315 mm	1/2" NPT	HBLC-Fgas-3.2-1-LED
441 mm	1/2" NPT	HBLC-Fgas-4.4-1-LED
566 mm	1/2" NPT	HBLC-Fgas-5.7-1-LED
602 mm	1/2" NPT	HBLC-Fgas-6-1-LED
762 mm	1/2" NPT	HBLC-Fgas-7.6-1-LED
816 mm	1/2" NPT	HBLC-Fgas-8.2-1-LED
882 mm	1/2" NPT	HBLC-Fgas-8.9-1-LED
1152 mm	1/2" NPT	HBLC-Fgas-11.5-1-LED
1640 mm	1/2" NPT	HBLC-Fgas-16.4-1-LED

Length	Thread type	Ordering codes
260 mm	3/4" NPT	HBLC-Fgas-2.6-2
315 mm	3/4" NPT	HBLC-Fgas-3.2-2
441 mm	3/4" NPT	HBLC-Fgas-4.4-2
566 mm	3/4" NPT	HBLC-Fgas-5.7-2
602 mm	3/4" NPT	HBLC-Fgas-6-2
762 mm	3/4" NPT	HBLC-Fgas-7.6-2
816 mm	3/4" NPT	HBLC-Fgas-8.2-2
882 mm	3/4" NPT	HBLC-Fgas-8.9-2
1152 mm	3/4" NPT	HBLC-Fgas-22.5-2
1640 mm	3/4" NPT	HBLC-Fgas-26.4-2
260 mm	3/4" NPT	HBLC-Fgas-2.6-2-LED*
315 mm	3/4" NPT	HBLC-Fgas-3.2-2-LED
441 mm	3/4" NPT	HBLC-Fgas-4.4-2-LED
566 mm	3/4" NPT	HBLC-Fgas-5.7-2-LED
602 mm	3/4" NPT	HBLC-Fgas-6-2-LED
762 mm	3/4" NPT	HBLC-Fgas-7.6-2-LED
816 mm	3/4" NPT	HBLC-Fgas-8.2-2-LED
882 mm	3/4" NPT	HBLC-Fgas-8.9-2-LED
1152 mm	3/4" NPT	HBLC-Fgas-22.5-2-LED
1640 mm	3/4" NPT	HBLC-Fgas-26.4-2-LED

\* Version with LED indication and display.

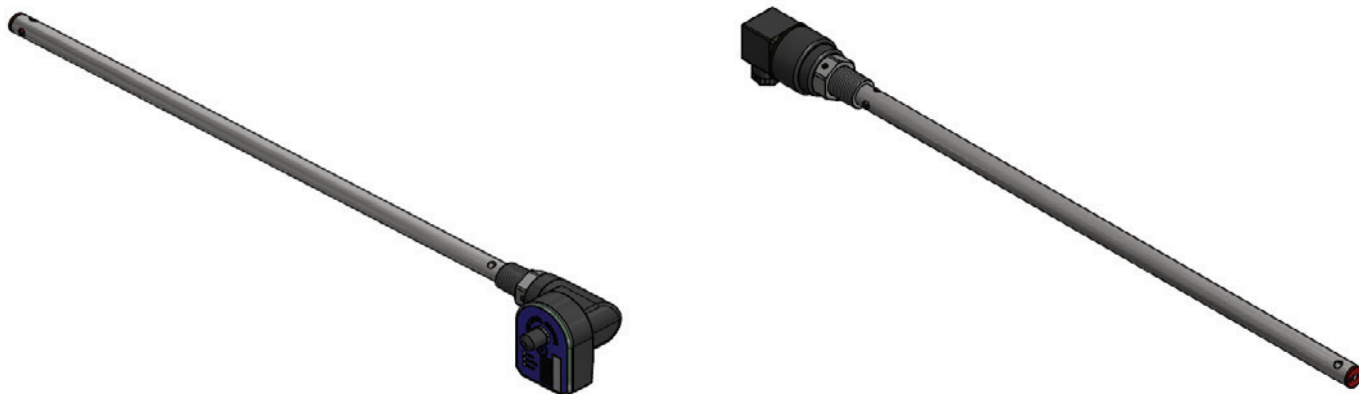

**Spare parts**











Length	Thread type	Ordering code
Mechanical parts		
260 mm	1/2" NPT	HBLC-Fgas-2.6-1-MEK
315 mm	1/2" NPT	HBLC-Fgas-3.2-1-MEK
441 mm	1/2" NPT	HBLC-Fgas-4.4-1-MEK
566 mm	1/2" NPT	HBLC-Fgas-5.7-1-MEK
602 mm	1/2" NPT	HBLC-Fgas-6-1-MEK
762 mm	1/2" NPT	HBLC-Fgas-7.6-1-MEK
816 mm	1/2" NPT	HBLC-Fgas-8.2-1-MEK
882 mm	1/2" NPT	HBLC-Fgas-8.9-1-MEK
1152 mm	1/2" NPT	HBLC-Fgas-11.5-1-MEK
1640 mm	1/2" NPT	HBLC-Fgas-16.4-1-MEK
260 mm	1/2" NPT	HBLC-Fgas-2.6-2-MEK
315 mm	1/2" NPT	HBLC-Fgas-3.2-2-MEK
441 mm	1/2" NPT	HBLC-Fgas-4.4-2-MEK
566 mm	1/2" NPT	HBLC-Fgas-5.7-2-MEK
602 mm	1/2" NPT	HBLC-Fgas-6-2-MEK
762 mm	1/2" NPT	HBLC-Fgas-7.6-2-MEK
816 mm	1/2" NPT	HBLC-Fgas-8.2-2-MEK
882 mm	1/2" NPT	HBLC-Fgas-8.9-2-MEK
1152 mm	1/2" NPT	HBLC-Fgas-22.5-2-MEK
1640 mm	1/2" NPT	HBLC-Fgas-26.4-2-MEK
Electronic parts		HBLC-Fgas-EL
		HBLC-Fgas-EL-LED



# Oil



# Switches, Sensors and Controllers for Oil in Industrial Refrigeration Installations

ON/OFF Switches			
Oil	<b>Function:</b> Oil Switch - 24 V AC/DC <b>Application:</b> Compressor crankcases, oil collectors/tanks & oil separators. <b>Oil Temperature:</b> 0...+90°C <b>Supply:</b> 24 V AC/DC <b>Output:</b> PNP/NPN - 1A		Page 129
	<b>Function:</b> Oil Switch - 90...240 V AC <b>Applications:</b> Compressor crankcases, oil collectors/tanks & oil separators. <b>Oil Temperature:</b> 0...+80°C <b>Supply:</b> 90...240 VAC <b>Output:</b> Solid state relay		Page 133
	<b>Function:</b> Low Temperature Oil Level Switch - 24 V AC/DC <b>Applications:</b> Compressor crankcases, oil collectors/tanks & oil separators. <b>Oil Temperature:</b> -30 °...90 °C <b>Supply:</b> 24 V AC/DC <b>Output:</b> PNP/NPN - 1A		Page 136
	<b>Function:</b> Low Temperature Oil Level Switch - 90...240 V AC <b>Applications:</b> Compressor crankcases, oil collectors/tanks & oil separators. <b>Oil Temperature:</b> -30 °...80 °C <b>Supply:</b> 90 - 240 V AC <b>Output:</b> Solid state relay output - 90...240 V AC - 40 W		Page 139
	<b>Function:</b> High Temperature Oil Switch - 24 V AC/DC <b>Applications:</b> Compressor crankcases, oil collectors/tanks & oil separators. <b>Oil Temperature:</b> 0...145 °C <b>Supply:</b> 24 V AC/DC <b>Output:</b> Solid state relay		Page 142
Phase change	<b>Function:</b> Oil Return Switch - 24 V AC/DC <b>Applications:</b> Oil pots and oil purgers <b>Oil Temperature:</b> -60...+80°C <b>Supply:</b> 24 V AC/DC + 10 % <b>Output:</b> PNP/NPN - 1A		Page 145
Oil	<b>Function:</b> Oil Level Sensor (Rod) <b>Applications:</b> Chillers, evaporators and condensers <b>Oil Temperature:</b> 0...+80°C <b>Supply:</b> 24 V AC/DC <b>Output:</b> 4...20 mA / PNP-1A		Page 148
Phase change	<b>Function:</b> Oil Level Controller / Management <b>Applications:</b> Oil separator, oil tanks, oil purgers or compressors <b>Oil Temperature:</b> 0...+80°C <b>Supply:</b> 24 V DC <b>Output:</b> Solid state relay		Page 151
	<b>Function:</b> Oil Pot Controller <b>Applications:</b> Oil level controller in oil pot <b>Oil Temperature:</b> -60...+80°C <b>Supply:</b> 24 V DC <b>Output:</b> Solid state relay - 1A		Page 153
	<b>Function:</b> Oil Ejector <b>Applications:</b> Oil drainage of NH <sub>3</sub> and CO <sub>2</sub> industrial refrigeration systems <b>Oil Temperature:</b> -60...+80°C <b>Max pressure:</b> Max 120 bar		Page 155



# Oil Switch - 24 V AC/DC

Category: HBSO



## Functional description

HBSO1 (PAO & mineral oil) and HBSO2 (POE & PAG oil) is a level switch for detecting common lubricating oils in refrigeration systems. Typically it is installed in/on the compressor and the oil separator, but it is also suited for installation in other locations in the oil system. The sensor's measurement principle makes it unique for these purposes, since the properties of the measurement principle allows it, among other things, to detect oil without detecting refrigerant. It is calibrated so that it is unaffected by oil spray and only allows a small amount of foam.

The sensor is also constructed to resist high pressure and temperatures.

- For almost 20 years switches from HB Products has been supplied worldwide.
- More than 10.000 switches are produced every year.
- We deliver switches as OEM products to the leading suppliers of industrial refrigeration equipment.

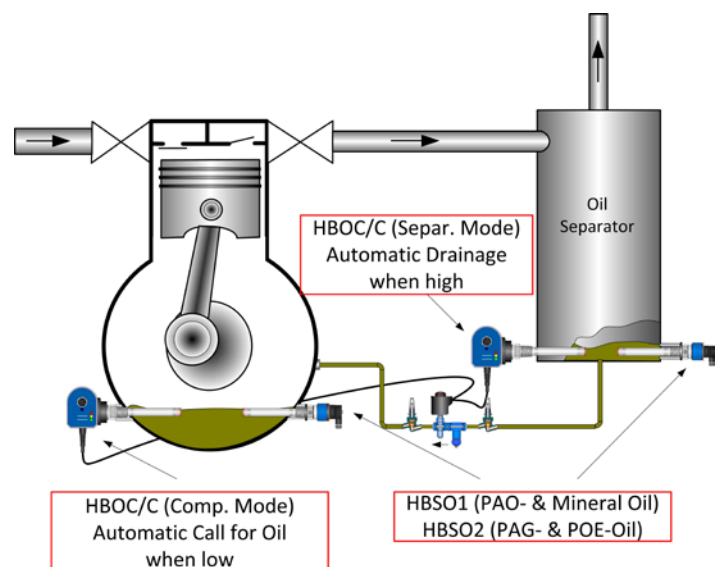

- Available as 2-wire sensor
- Now with ATEX / IECEx certificate (This version is without LED display)

## Technical data

Power supply		Mechanical specifications	
Voltage	24 V AC/DC + 10%	Thread connection	½",¾" & 1 1/8" NPT /BSPP"
Current consumption - sensor only*	200 mA	Material – mechanical parts	AISI 304 / PTFE
Max. current output	Max 50 mA	Material – electronic parts	Nylon 6 (PA)
Plug connection	ISO 4400/DIN 43650	Dimensions	192x52x40
Output		Environmental conditions	
Output type	PNP or NPN - 50 mA	Ambient temperature	-30...+50°C
Output function	NC or NO	Oil temperature*	0...+90°C
LED indication	4 x LED (red)	Max pressure	150 bar
Cable specification**		Protection degree	IP65
Cable size	3 x 0.34 mm <sup>2</sup>	Vibrations	IEC 68-2-6 (4g)
Cable glands	PG7 / M8	Oil type	
Cable resistance	500 Ω/Km	HBSO1	PAO & mineral oil
Approvals		HBSO2	POE & PAG
CE	EN 61000-2		

\* Total consumption is sensor consumption plus output and it depends on ambient temperature.

\*\* Cable not included.

## Mechanical dimensions

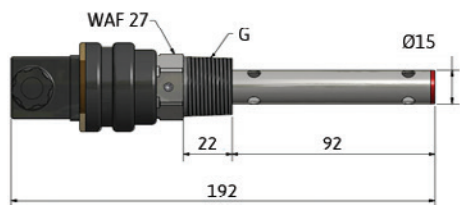

1/2" & 3/4"

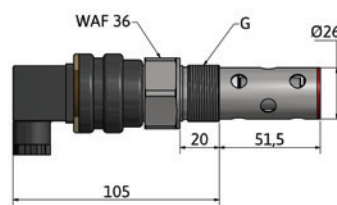
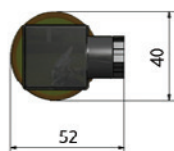

1 1/8" UNEF

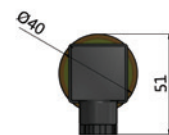

4 x red LED's indicate liquid detection.  
 4 x green LED's flashing indicate no detection, but sensor is active.  
 4 x red flashing LED's indicate no connection to mechanical unit.

### Switch contact output:

**NC:** Relay contact is normally closed (current can flow) and opens when liquid is detected.

**NO:** Relay contact is normally open (no current flow) and closes when liquid is detected.

## Ordering codes

Output	Thread type (G)	Ordering code
PNP / NO	1/2" NPT	HBSO1-PNP/NO-1
PNP / NC	1/2" NPT	HBSO1-PNP/NC-1
PNP / NO	3/4" NPT	HBSO1-PNP/NO-2
PNP / NC	3/4" NPT	HBSO1-PNP/NC-2
PNP / NO	1/2" BSPP	HBSO1-PNP/NO-5
PNP / NC	1/2" BSPP	HBSO1-PNP/NC-5
PNP / NO	3/4" BSPP	HBSO1-PNP/NO-6
PNP / NC	3/4" BSPP	HBSO1-PNP/NC-6
PNP / NO	1 1/8" UNEF	HBSO1-PNP/NO-7
PNP / NC	1 1/8" UNEF	HBSO1-PNP/NC-7
NPN / NO	1/2" NPT	HBSO1-NPN/NO-1
NPN / NC	1/2" NPT	HBSO1-NPN/NC-1
NPN / NO	3/4" NPT	HBSO1-NPN/NO-2
NPN / NC	3/4" NPT	HBSO1-NPN/NC-2
NPN / NO	1/2" BSPP	HBSO1-NPN/NO-5
NPN / NC	1/2" BSPP	HBSO1-NPN/NC-5
NPN / NO	3/4" BSPP	HBSO1-NPN/NO-6
NPN / NC	3/4" BSPP	HBSO1-NPN/NC-6
NPN / NO	1 1/8" UNEF	HBSO1-NPN/NO-7
NPN / NC	1 1/8" UNEF	HBSO1-NPN/NC-7
PNP / NO	1/2" NPT	HBSO2-PNP/NO-1
PNP / NC	1/2" NPT	HBSO2-PNP/NC-1

PNP / NO	3/4" NPT	HBSO2-PNP/NO-2
PNP / NC	3/4" NPT	HBSO2-PNP/NC-2
PNP / NO	1/2" BSPP	HBSO2-PNP/NO-5
PNP / NC	1/2" BSPP	HBSO2-PNP/NC-5
PNP / NO	3/4" BSPP	HBSO2-PNP/NO-6
PNP / NC	3/4" BSPP	HBSO2-PNP/NC-6
PNP / NO	1 1/8" NEF	HBSO2-PNP/NO-7
PNP / NC	1 1/8" UNEF	HBSO2-PNP/NC-7
NPN / NO	1/2" NPT	HBSO2-NPN/NO-1
NPN/NC	1/2" NPT	HBSO2-NPN/NC-1
NPN/NO	3/4" NPT	HBSO2-NPN/NO-2
NPN/NC	3/4" NPT	HBSO2-NPN/NC-2
NPN/NO	1/2" BSPP	HBSO2-NPN/NO-5
NPN/NC	1/2" BSPP	HBSO2-NPN/NC-5
NPN/NO	3/4" BSPP	HBSO2-NPN/NO-6
NPN/NC	3/4" BSPP	HBSO2-NPN/NC-6
NPN/NO	1 1/8" UNEF	HBSO2-NPN/NO-7
NPN/NC	1 1/8" UNEF	HBSO2-NPN/NC-7

Please specify the oil application by "1" for PAO & mineral oil and by "2" for POE & PAG oil.

## Spare parts

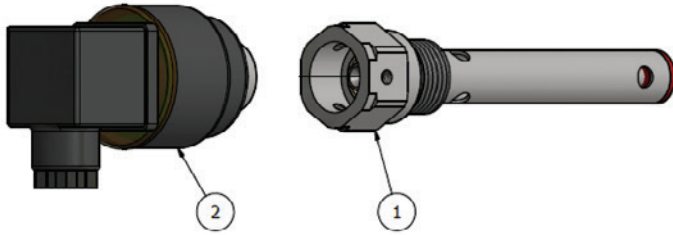

Position	Specification	Type	Ordering code
2	Electronic parts - HBSO1	PNP/NO	HBSO1-EL/PNP/NO
		PNP/NC	HBSO1-EL/PNP/NC
		NPN/NO	HBSO1-EL/NPN/NO
		NPN/NC	HBSO1-EL/NPN/NC
	Electronic parts - HBSO2	PNP/NO	HBSO2-EL/PNP/NO
		PNP/NC	HBSO2-EL/PNP/NC
		NPN/NO	HBSO2-EL/NPN/NO
		NPN/NC	HBSO2-EL/NPN/NC
1	Mechanical parts	1/2" NPT	HBSO1-MEK-1
		3/4" NPT	HBSO1-MEK-2
		1/2" BSPP	HBSO1-MEK-5
		3/4" BSPP	HBSO1-MEK-6
		1 1/8" UNEF	HBSO1-MEK-7

# Oil Switch - 90...240 V AC

Category: HBSO-SSR-2

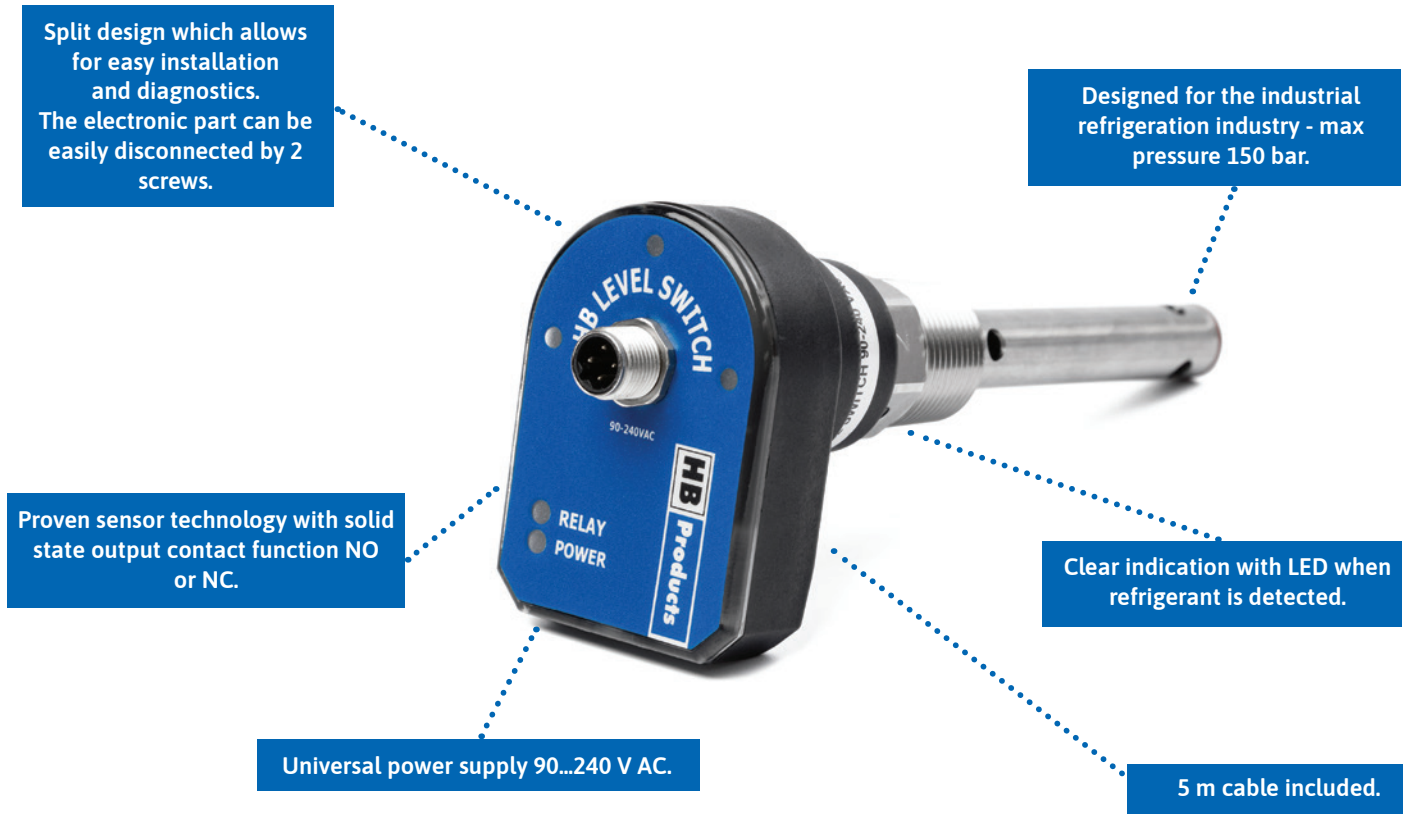

## Functional description:

HBSO1 (PAO & mineral oil) and HBSO2 (POE & PAG oil) is a level switch for detecting common lubricating oils in refrigeration systems. Typically it is installed in/on the compressor and the oil separator, but it is also suited for installation in other locations in the oil system. The sensor's measurement principle makes it unique for these purposes, since the properties of the measurement principle allows it, among other things, to detect oil without detecting refrigerant. It is calibrated so that it is unaffected by oil spray and only allows a small amount of foam. The sensor is also constructed to resist high pressure and temperatures.

The switch has a built-in local power supply for direct use on grid supply 90...240 V AC. A solid state relay can also operate a valve directly.

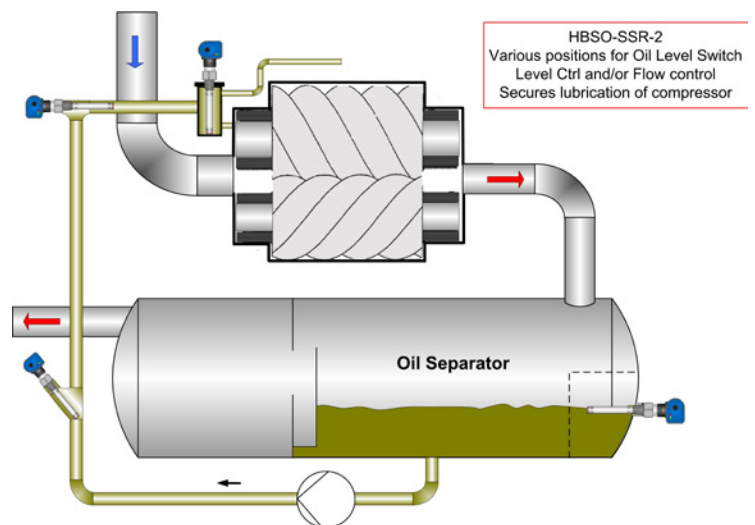

## Technical data

Power supply		Mechanical specifications	
Voltage	90...240 V AC	Thread connection	½",¾" & 1 1/8" NPT /BSPP
Current consumption - sensor only*	<10 mA	Material - mechanical parts	AISI 304 / PTFE
Max. current output	Max 50 mA	Material - electronic parts	Nylon 6 (PA)
Plug connection	M12 - DIN 0627	Dimensions	See drawing
Output		Environmental conditions	
Solid state relay output	90-240 VAC-40W	Ambient temperature	-30...+50°C
Output function	NC or NO	Oil temperature	0...+80°C
LED indication		Max pressure	150 bar
Level indication	3 x LED (green)	Protection degree	IP65
Power supply	1 x LED (green)	Vibrations	IEC 68-2-6 (4g)
Relay-on activation	1 x LED (yellow)		
Cable specification (power supply)			
Cable size	5m - 3 x 0,34 mm2		
Cable glands	PG7 / M8		
Cable resistance	500 Ω/Km		
Approvals			
CE	EN 61000-2		

\* Total consumption is sensor consumption plus output and it depends on ambient temperature.

## Mechanical dimensions

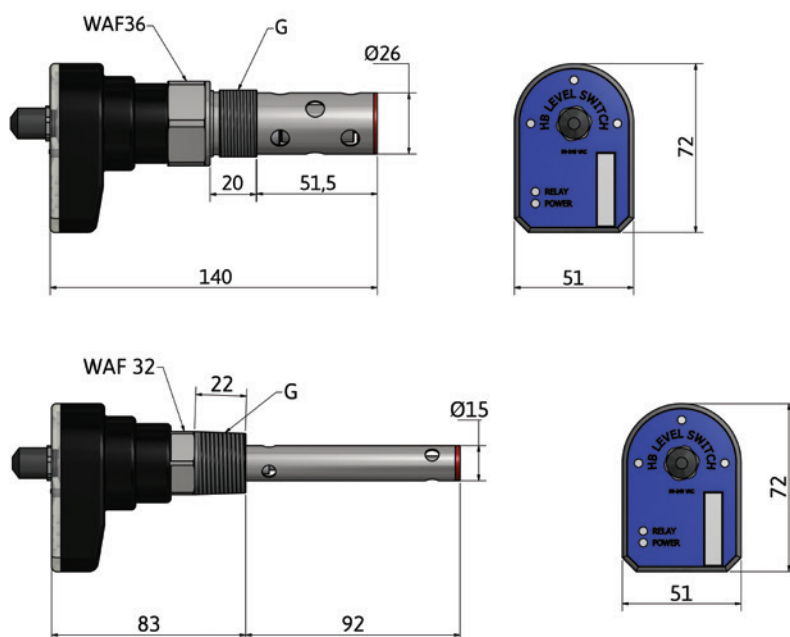

## Ordering codes

Output	Thread type (G)	Oil type	Temperature	Ordering code
NO	½" NPT	PAO, mineral	0...80 °C	HBSO1-SSR-2/NO-1
NC	½" NPT	PAO, mineral	0...80 °C	HBSO1-SSR-2/NC-1
NO	¾" NPT	PAO, mineral	0...80 °C	HBSO1-SSR-2/NO-2
NC	¾" NPT	PAO, mineral	0...80 °C	HBSO1-SSR-2/NC-2
NO	½" BSPP	PAO, mineral	0...80 °C	HBSO1-SSR-2/NO-5
NC	½" BSPP	PAO, mineral	0...80 °C	HBSO1-SSR-2/NC-5
NO	¾" BSPP	PAO, mineral	0...80 °C	HBSO1-SSR-2/NO-6
NC	¾" BSPP	PAO, mineral	0...80 °C	HBSO1-SSR-2/NC-6
NO	1 1/8" UNEF	PAO, mineral	0...80 °C	HBSO1-SSR-2/NO-7
NC	1 1/8" UNEF	PAO, mineral	0...80 °C	HBSO1-SSR-2/NC-7
NO	½" NPT	POE, PAG	0...80 °C	HBSO2-SSR-2/NO-1
NC	½" NPT	POE, PAG	0...80 °C	HBSO2-SSR-2/NC-1
NO	¾" NPT	POE, PAG	0...80 °C	HBSO2-SSR-2/NO-2
NC	¾" NPT	POE, PAG	0...80 °C	HBSO2-SSR-2/NC-2
NO	½" BSPP	POE, PAG	0...80 °C	HBSO2-SSR-2/NO-5
NC	½" BSPP	POE, PAG	0...80 °C	HBSO2-SSR-2/NC-5
NO	¾" BSPP	POE, PAG	0...80 °C	HBSO2-SSR-2/NO-6
NC	¾" BSPP	POE, PAG	0...80 °C	HBSO2-SSR-2/NC-6
NO	1 1/8" UNEF	POE, PAG	0...80 °C	HBSO2-SSR-2/NO-7
NC	1 1/8" UNEF	POE, PAG	0...80 °C	HBSO2-SSR-2/NC-7

## Spare parts

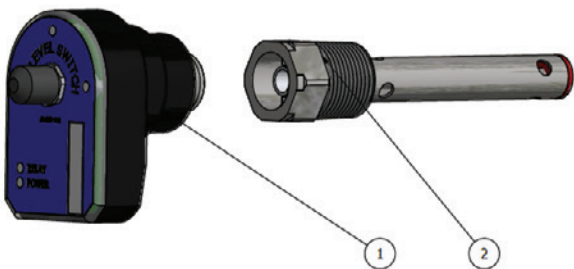

Position	Specification	Type	Ordering code
1	Electronic parts - HBSO1	NO	HBSO1-SSR-2/NO-EL
		NC	HBSO1-SSR-2/NC-EL
	Electronic parts - HBSO2	NO	HBSO2-SSR-2/NO-EL
		NC	HBSO2-SSR-2/NC-EL
2	Mechanical parts	1/2" NPT	HBSO1-MEK-1
		3/4" NPT	HBSO1-MEK-2
		1/2" BSPP	HBSO1-MEK-5
		3/4" BSPP	HBSO1-MEK-6
		1 1/8 UNEF	HBSO1-MEK-7

# Low Temperature Oil Switch - 24 V AC/DC

Category: HBSO-U-LT

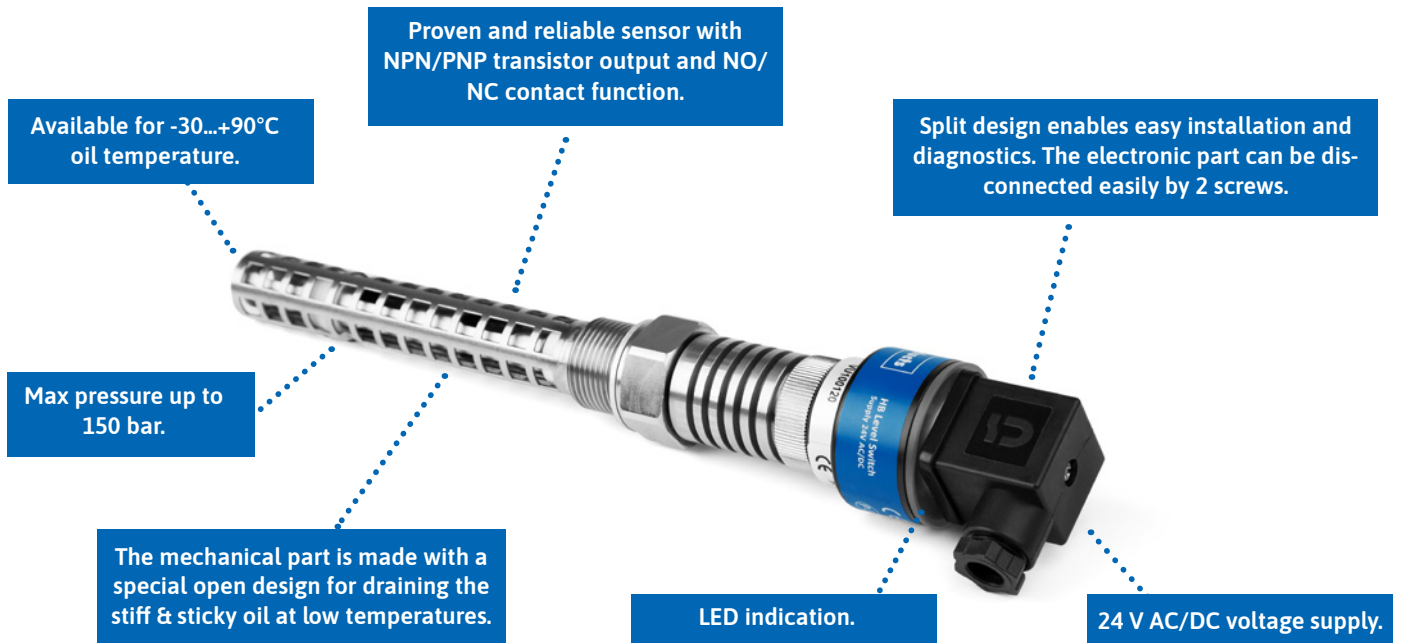

## Functional description:

HBSO-U-LT is level switch used for detecting oil in a low temperature refrigeration systems. The switch is specially developed for low temperature applications like in CO<sub>2</sub> systems. The HBSO switch can be used for all types PAO, POE, mineral oil and PAG oil.

Typically it is installed in / on the compressor and the oil separator, but it is also suited for installation in other parts of the oil system.

The electronic sensor head is the same as the one used for the regular HBSO1 and HBSO2 sensors – but with other settings. The mechanical part has a special open design made for draining the stiff and sticky cold oil.

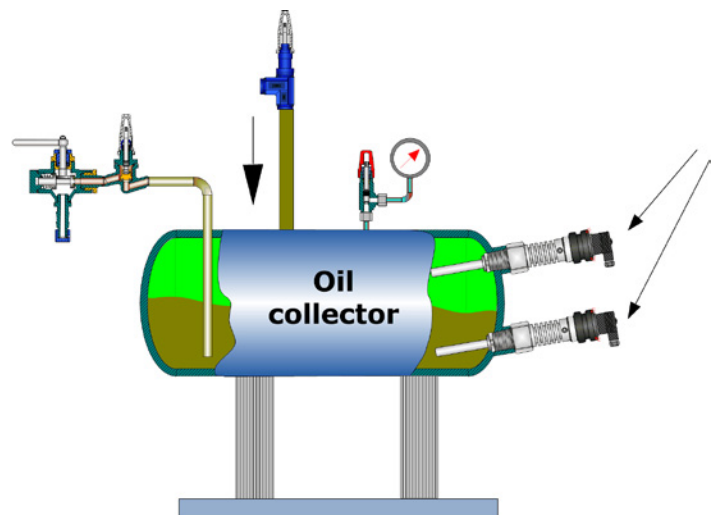



## Technical data - sensor

Power supply		Mechanical Specifications	
Supply	24 V AC/DC $\pm 10\%^*$	Thread connection	$\frac{3}{4}$ " NPT & $\frac{3}{4}$ " BSPP
Current consumption - sensor only*	200 mA	Materials - mechanical parts:	AISI304/PTFE
Max current output	50 mA	Materials - electronic parts:	Nylon 6 (PA)
Plug connection	ISO 4400/DIN 43650	Dimensions	277 x 40 mm / 485 g
Output		Installation conditions:	
Output type	PNP or NPN - 50 mA	Ambient temperature	-30°...+50°C
Output function	NC or NO	Oil temperature	-30°...+90°C
LED indication	4 x LED (red)	Max. operational pressure:	150 bar
		Protection degree	IP65
Approvals		Vibrations	IEC 68-2-6 (4g)
EMC test	EN61000-2		
EMC Emission:		Oil type	
	EN61000-3-2	HBSO	All oil types: PAO, POE, mineral & PAG
EMC Immunity:	EN61000-4-2		

\* Total consumption is sensor consumption plus output and it depends on ambient temperature.

## Mechanical dimensions

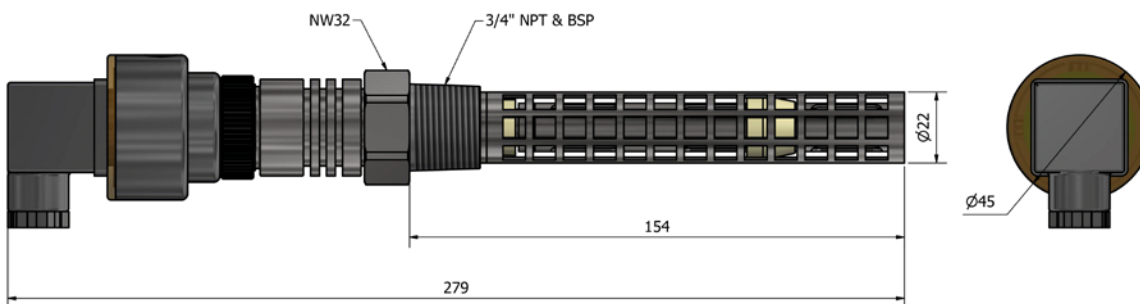

## Ordering codes

Output	Thread type	Oil type	Oil temperature	Ordering code
PNP / NO	3/4" NPT	All types*	-30...90 °C	HBSO-U-PNP/NO-2-LT
PNP / NC	3/4" NPT	All types*	-30...90 °C	HBSO-U-PNP/NC-2-LT
NPN / NO	3/4" NPT	All types*	-30...90 °C	HBSO-U-NPN/NO-2-LT
NPN / NC	3/4" NPT	All types*	-30...90 °C	HBSO-U-NPN/NC-2-LT
PNP / NO	3/4" BSPP (G)	All types*	-30...90 °C	HBSO-U-PNP/NO-6-LT
PNP / NC	3/4" BSPP (G)	All types*	-30...90 °C	HBSO-U-PNP/NC-6-LT
NPN / NO	3/4" BSPP (G)	All types*	-30...90 °C	HBSO-U-NPN/NO-6-LT
NPN / NC	3/4" BSPP (G)	All types*	-30...90 °C	HBSO-U-NPN/NC-6-LT

\*All common PAO, PEO, mineral & PAG oil types.

## Spare parts

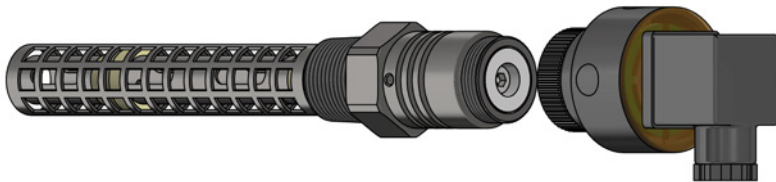

Position	Specification	Type	Ordering code
1.	Electronic parts	NPN/NO	HBSO-U-NPN/NO-EL-LT
		NPN/NC	HBSO-U-NPN/NC-EL-LT
		PNP/NO	HBSO-U-PNP/NO-EL-LT
		PNP/NC	HBSO-U-PNP/NC-EL-LT
2.	Mechanical parts	3/4" NPT	HBSO-U-LT-MEK-2
		3/4" BSPP	HBSO-U-LT-MEK-6

# Low Temperature Oil Switch 90 - 240 V AC

Category: HBSO-SSR-2-LT



## Functional description

HBSO-U-LT is a low temperature level switch used for detecting common lubricating oils in refrigeration systems. The switch is special developed for low temperature applications.

The HBSO version of the low temperature oil switch can be used for all types PAO, POE, mineral oil and PAG oil.

Typically it is installed in / on the compressor and the oil separator, but it is also suited for installation in other locations in the oil system. The sensor's measurement principle makes it unique for these purposes, since the properties of the measurement principle allows it, among other things, to detect oil without detecting refrigerant.

It is calibrated so that it is unaffected by oil spray and only allows a small amount of foam.

The electronic sensor head is the same as the one used for the regular HBSO1 and HBSO2 sensors. The mechanical part has got a special open design made for draining the stiff and sticky oil at low temperatures on the low pressure side of a cooling plant.

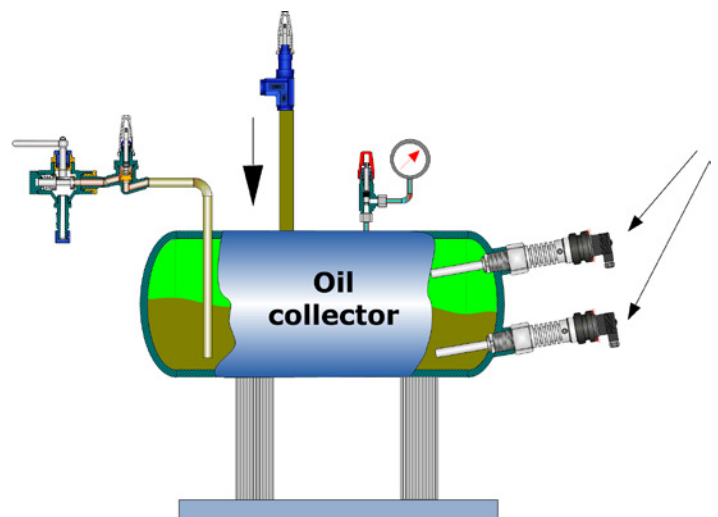

## Technical data - sensor

Supply		Mechanical Specifications	
Supply:	90...240 V AC	Thread connection	3/4" NPT & 3/4" BSPP
Current consumption - sensor only*	< 10 mA	Materials - mechanical parts:	AISI304/PTFE
Max current output	Max 50 mA	Materials - electronic parts:	Nylon 6 (PA)
Plug connection	M12 - DIN 0627	Dimensions	278 x 51 x 72 mm
		Weight	605 g
Output		Installation conditions:	
Solid state relay output:	90...240 V AC - 40 W	Ambient temperature	-30°...+50°C
Output function	NC or NO	Oil temperature	-30°...+80°C
LED indication		Max. operational pressure:	150 bar
Level indication:	3 x LED (green)	Protection degree	IP66
Relay-on activation:	1 x LED (yellow)	Vibrations	IEC 68-2-6 (4g)
Power supply:	1 x LED (green)	Oil type	
Approvals		HBSO-SSR-2-LT	All common PAO, POE, mineral & PAG oil types
EMC Emission:	EN61000-3-2		
EMC Immunity:	EN61000-4-2		

\* Total consumption is sensor consumption plus output and it depends on ambient temperature.

## Mechanical dimensions

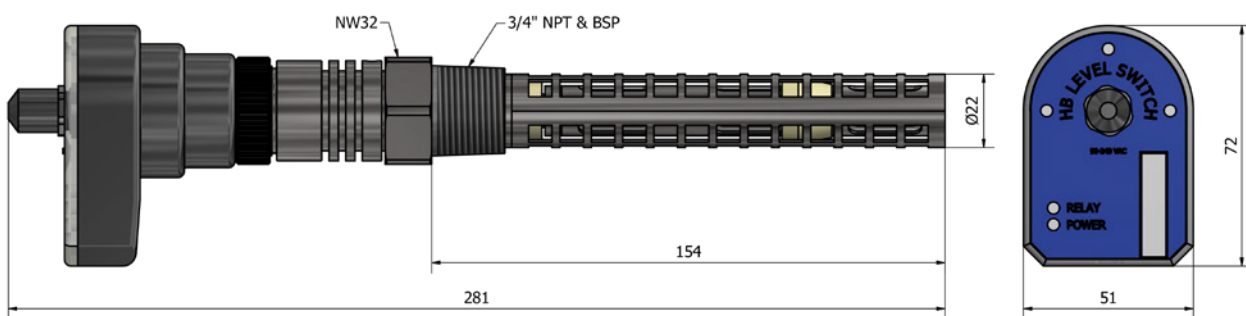

## Ordering codes

Output	Thread type	Oil type	Oil temperature	Ordering code
NO	3/4" NPT	All types*	-30...80 °C	HBSO-U-SSR2/NO-2-LT
NC	3/4" NPT	All types*	-30...80 °C	HBSO-U-SSR2/NC-2-LT
NO	3/4" BSPP	All types*	-30...80 °C	HBSO-U-SSR2/NO-6-LT
NC	3/4" BSPP	All types*	-30...80 °C	HBSO-U-SSR2/NC-6-LT

\*All common PAO, POE, mineral & PAG oil types.

## Spare parts

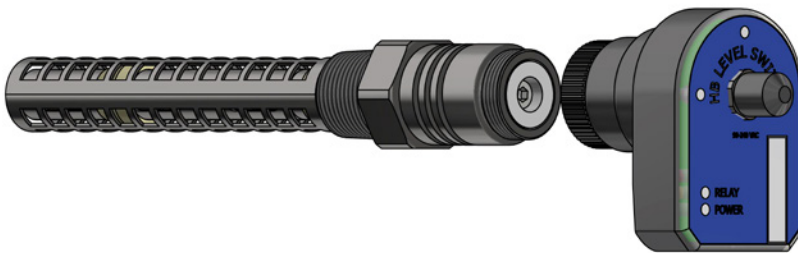

Position	Specification	Type	Ordering code
1.	Electronic parts	NO	HBSO-U-SSR2/NO-EL-LT
		NC	HBSO-U-SSR2/NC-EL-LT
2.	Mechanical parts	3/4" NPT	HBSO-U-LT-MEK-2
		3/4" BSPP	HBSO-U-LT-MEK-6

# High Temperature Oil Switch - 24 V AC/DC

Category: HBSO-SSR-1/xx-x/HT



## Functional description:

HBSO-SSR-1/XX-X-HT is a high temperature level switch for detecting common lubricating oils in refrigeration systems. The level switch is used for all oil types (PAO, POE, mineral oil and PAG oil). Typically it is installed in/on the compressor and the oil separator, but it is also suited for installation in other locations in the oil system. The sensor's measurement principle makes it unique for these purposes, since the properties of the measurement principle allows it, among other things, to detect oil without detecting refrigerant. It is calibrated so that it is unaffected by oil spray and only allows a small amount of foam. The sensor is also constructed to resist high pressure and temperatures.

A solid state relay can also operate a valve directly.

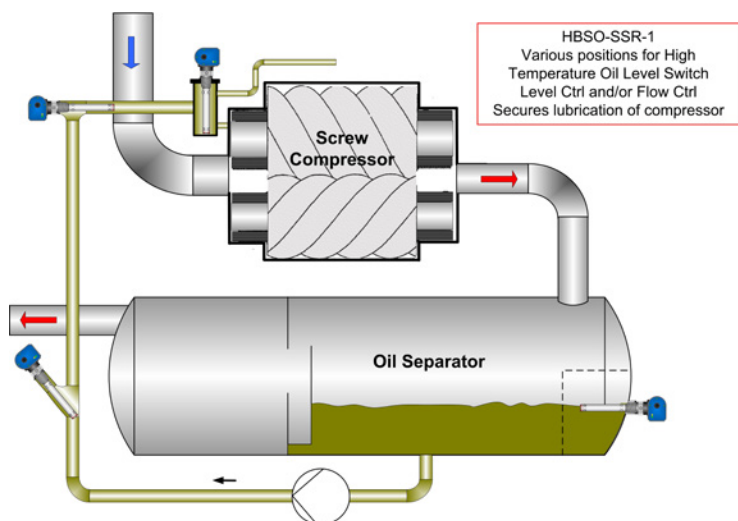

## Technical data

Power supply		Mechanical specifications	
Voltage	24 V AC/DC	Thread connection	½", ¾" NPT / BSPP and 1 1/8" UNEF
Current consumption - sensor only*	30 mA	Material - mechanical parts	AISI 304 / PTFE
		Material - electronic parts	Nylon 6 (PA)
Plug connection	M12 - DIN 0627	Dimensions	See drawing
Output		Environmental conditions	
Output type	Solid state relay - 40W	Ambient temperature	-30...+50°C
Output function	NC or NO	Oil temperature	0...+145°C
LED indication		Max pressure	150 bar
Level indication	3 x LED (green)	Protection degree	IP54
Power supply	1 x LED (green)	Vibrations	IEC 68-2-6 (4g)
Relay-on activation	1 x LED (yellow)	Oil type	
Alarm	1 x LED (red)	HBSO	PAO, POE, PAG & Mineral
Cable specification (power supply)			
Cable size	5m - 3 x 0.25 mm <sup>2</sup>		
Cable resistance	500 Ω/Km		
Approvals			
CE	EN 61000-2		

\* Total consumption is sensor consumption plus output and it depends on ambient temperature.

## Mechanical dimensions

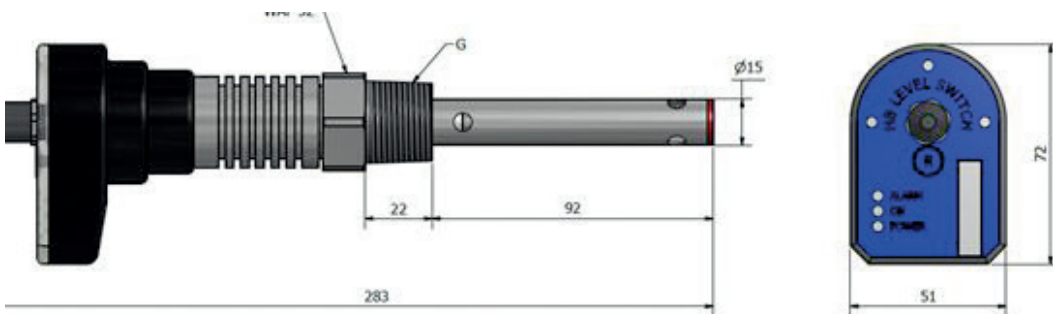

## Ordering codes

Output	Thread type (G)	Oil type	Temperature	Ordering code
NO	1/2" NPT	All types	0...145 °C	HBSO-SSR-1/NO-1/HT
NO	3/4" NPT	All types	0...145 °C	HBSO-SSR-1/NO-2/HT
NO	1/2" BSPP	All types	0...145 °C	HBSO-SSR-1/NO-5/HT
NO	3/4" BSPP	All types	0...145 °C	HBSO-SSR-1/NO-6/HT
NO	1 1/8" UNEF	All types	0...145 °C	HBSO-SSR-1/NO-7/HT
NC	1/2" NPT	All types	0...145 °C	HBSO-SSR-1/NC-1/HT
NC	3/4" NPT	All types	0...145 °C	HBSO-SSR-1/NC-2/HT
NC	1/2" BSPP	All types	0...145 °C	HBSO-SSR-1/NC-5/HT
NC	3/4" BSPP	All types	0...145 °C	HBSO-SSR-1/NC-6/HT
NC	1 1/8" UNEF	All types	0...145 °C	HBSO-SSR-1/NC-7/HT

## Spare parts

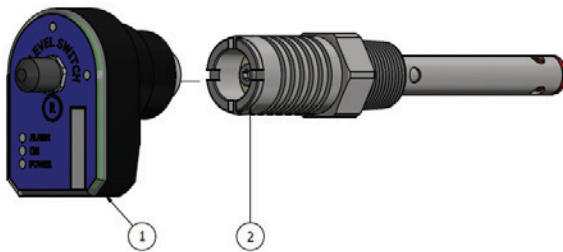

Position	Specification	Type	Ordering code
1	Electronic parts	NO	HBSO-SSR-1/NO-EL/HT
		NC	HBSO-SSR-1/NC-EL/HT
2	Mechanical parts	1/2" NPT	HBSO-MEK-1/HT
		3/4" NPT	HBSO-MEK-2/HT
		1/2" BSPP	HBSO-MEK-5/HT
		3/4" BSPP	HBSO-MEK-6/HT
		1 1/8" UNEF	HBSO-MEK-7/HT



# Oil Return Switch - 24 V AC/DC

Category: HBOR-U

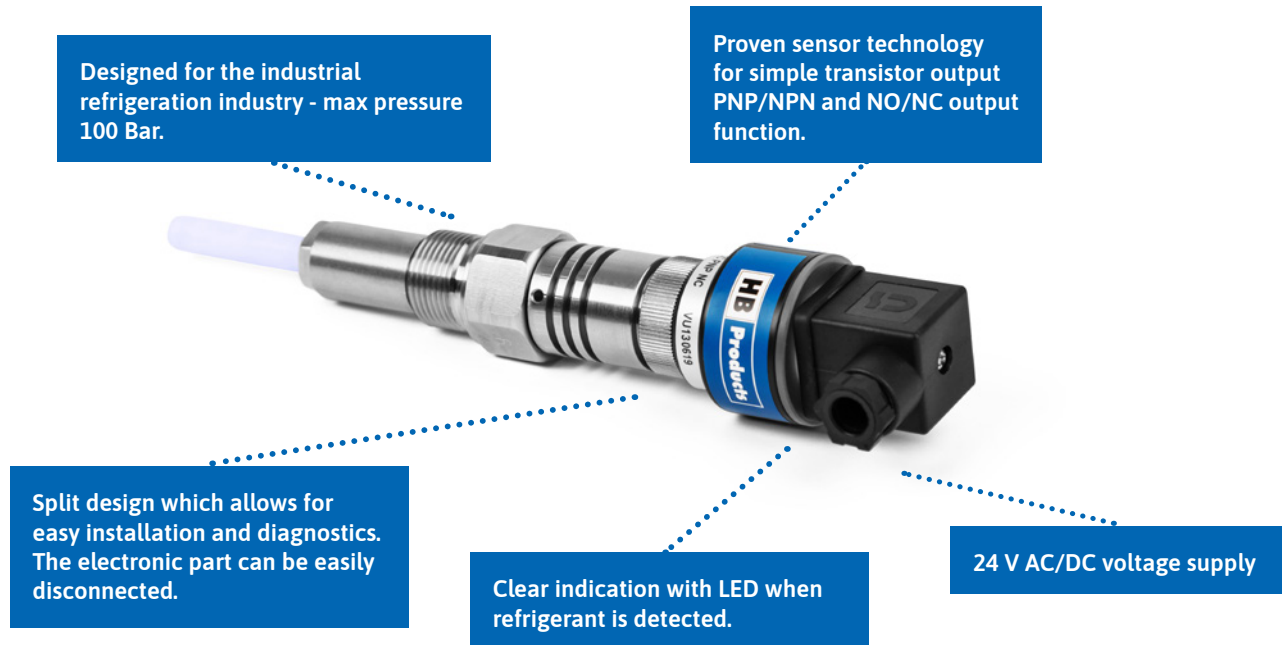

## Functional description

HBOR-U is a level switch for detection of oil in an oil collection point in ammonia systems. The sensor is built to resist high pressure and low temperatures.

HBOR-U is not suited for use in systems other than ammonia systems.

HBOR-U is a liquid level switch designed for automatic Oil Return. The sensor measures and detects the difference between the refrigerant and oil in a refrigeration system. Increased security is achieved as the sensor measures when the oil is drained and hence surrounded by ammonia, the sensor closes the drain valve, without the risk of ammonia emission to the surroundings. Used for oil return / discharging of separated oil in e.g. evaporators, receivers and oil pots.

The sensor is calibrated to switch in the center of the sensor's cylindrical part, with a hysteresis of about 1 mm. When the oil is on the same level or above this point, 4 LEDs light up (irrespective of the output relay NO/NC).

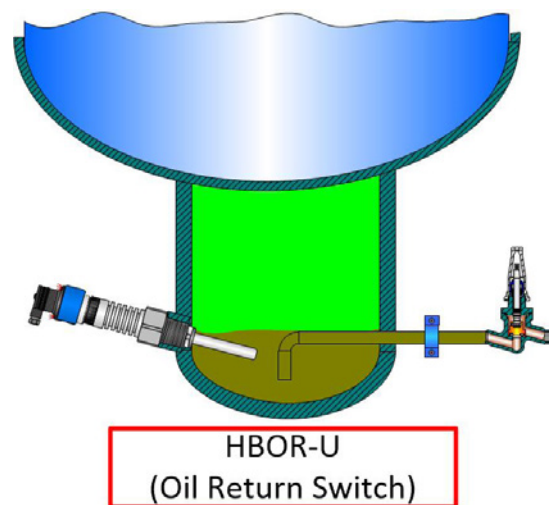

## Technical data

Power supply		Mechanical specifications	
Voltage	24 V AC/DC + 10%	Thread connection	3/4" NPT / BSPP
Current consumption - sensor only	200 mA	Material – mechanical parts	AISI 304 / PTFE
Max. current output	Max 50 mA	Material – electronic parts	Nylon 6 (PA)
Plug connection	ISO 4400/DIN 43650	Dimensions	210x52x40
Output		Environmental conditions	
Output type	PNP or NPN - 50 mA	Ambient temperature	-30...+50°C
Output function	NC or NO	Oil temperature*	-60...+80°C
LED indication	4 x LED (red)	Max pressure	100 bar
Cable specification**		Protection degree	IP65
Cable size	3 x 0.34 mm <sup>2</sup>	Vibrations	IEC 68-2-6 (4g)
Cable glands	PG7 / M8	Accessories	
Cable resistance	500 Ω/Km	Oil Ejector (0,05 l / min)	HBEJ-0.05-G3/8-MK2
Approvals			
CE	EN 61000-2		

\* Total consumption is sensor consumption plus output and it depends on ambient temperature.

\*\* Cable not included.

## Mechanical dimensions

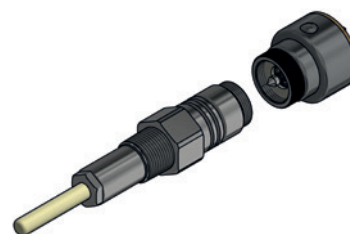
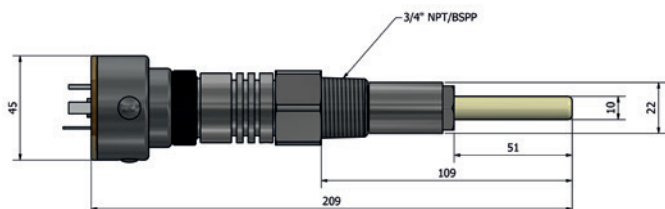

Thread to be sealed with conductive liquid sealing to ensure ground connection.

4 x red LED's indicate liquid detection.  
 4 x green LED's flashing indicate no detection, but sensor is active.  
 4 x red flashing LED's indicate no connection to mechanical unit.

### Switch contact output:

**NC:** Relay contact is normally closed (current can flow) and opens when liquid is detected.

**NO:** Relay contact is normally open (no current flow) and closes when liquid is detected.

## Ordering codes

Output	Thread type (G)	Ordering code
PNP / NO	1/2" NPT	HBOR-U-PNP/NO-1
PNP / NC	1/2" NPT	HBOR-U-PNP/NC-1
PNP / NO	3/4" NPT	HBOR-U-PNP/NO-2
PNP / NC	3/4" NPT	HBOR-U-PNP/NC-2
PNP / NO	1/2" BSPP	HBOR-U-PNP/NO-5
PNP / NC	1/2" BSPP	HBOR-U-PNP/NC-5
PNP / NO	3/4" BSPP	HBOR-U-PNP/NO-6
PNP / NC	3/4" BSPP	HBOR-U-PNP/NC-6
NPN / NO	1/2" NPT	HBOR-U-NPN/NO-1
NPN / NC	1/2" NPT	HBOR-U-NPN/NC-1
NPN / NO	3/4" NPT	HBOR-U-NPN/NO-2
NPN / NC	3/4" NPT	HBOR-U-NPN/NC-2
NPN / NO	1/2" BSPP	HBOR-U-NPN/NO-5
NPN / NC	1/2" BSPP	HBOR-U-NPN/NC-5
NPN / NO	3/4" BSPP	HBOR-U-NPN/NO-6
NPN / NC	3/4" BSPP	HBOR-U-NPN/NC-6

## Spare parts for HBOR-U

Position	Specification	Type	Ordering code
1	Electronic parts	PNP/NO	HBOR-U-EL/PNP/NO
		PNP/NC	HBOR-U-EL/PNP/NC
		NPN/NO	HBOR-U-EL/NPN/NO
		NPN/NC	HBOR-U-EL/NPN/NC
2	Mechanical parts	1/2" NPT	HBSR-U-MEK-1
		3/4" NPT	HBSR-U-MEK-2
		1/2" BSPP	HBSR-U-MEK-5
		3/4" BSPP	HBSR-U-MEK-6

## Spare parts for HBOR

Position	Specification	Type	Ordering code
1	Electronic parts	PNP/NO	HBOR-EL/PNP/NO
		PNP/NC	HBOR-EL/PNP/NC
		NPN/NO	HBOR-EL/NPN/NO
		NPN/NC	HBOR-EL/NPN/NC

# Oil Level Sensor

Category: HBLC-OIL

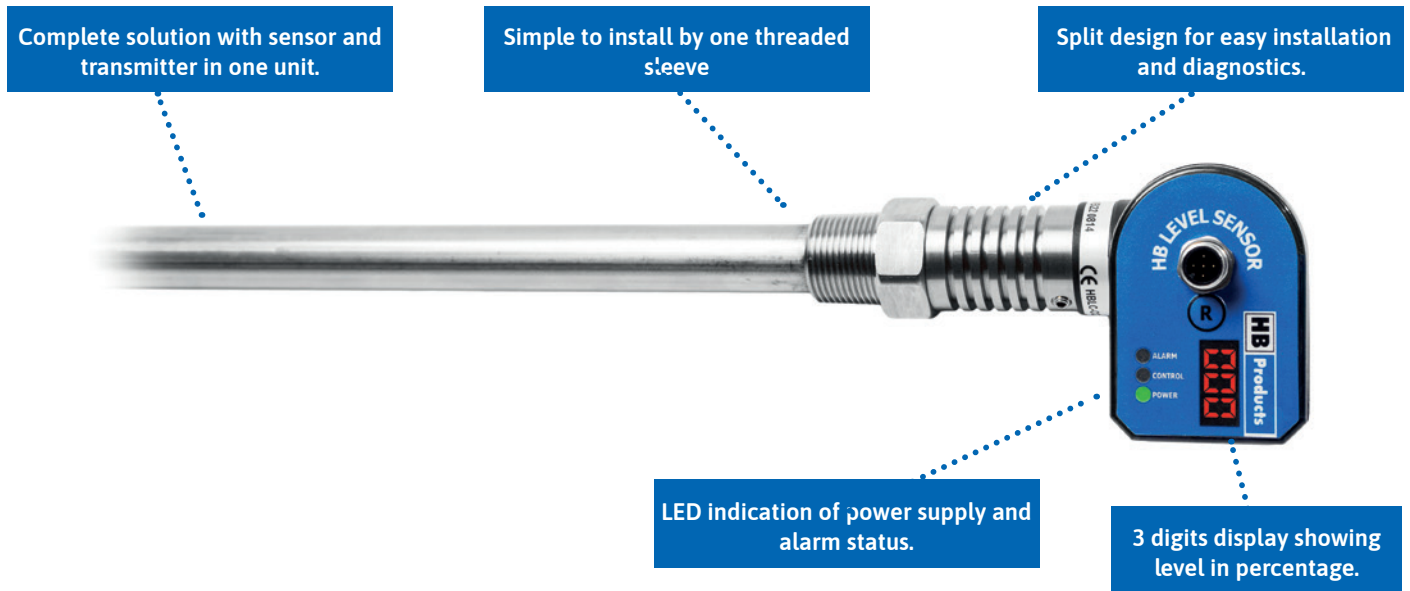

## Functional description:

HBLC-OIL is an intelligent sensor with a built-in microprocessor. It is designed for continuous level measurement of PAO, M & E oil types.

HBLC-OIL is designed for the measurement of oil levels.

The sensor emits a 4-20mA analog signal, which is proportional to the liquid level.

The construction of the sensor makes it suitable for systems with pressure of up to 150 bar.

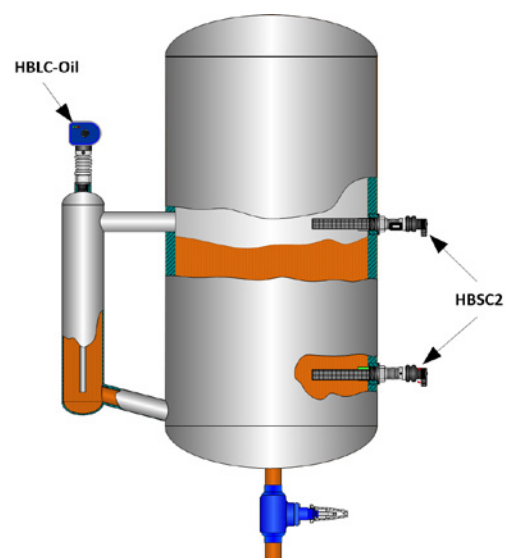

• Now with ATEX / IECEx certificate (The Atex version is without LED display)

## Technical data

Supply		Mechanical Specifications	
Supply:	24 V AC/DC $\pm 10\%$ *	Thread connection	$\frac{3}{4}$ " NPT & BSPP
Current consumption - sensor only*	Max 50 mA	Materials - mechanical parts:	AISI304/PTFE
Plug	M12, 5 pins - DIN 0627	Materials - electronic parts:	Nylon 6 (PA)
		Dimensions	See drawing
Output		Installation conditions:	
Analog output	4-20 mA	Ambient temperature	-30...+50°C
Permitted load on potential free contactless set	1A (24V DC)	Oil temperature	0...+145°C
LED indication	Green, yellow, and red	Max. operational pressure:	150 bar
Cable specification		Protection degree	IP65
Supply cable, 5 meters	HBxC-M12/5	Vibrations	IEC 68-2-6 (4g)
Cable size	PUR - 5 x 0,34 mm <sup>2</sup>		
Approvals			
EMC Emission:	EN61000-3-2		
EMC Immunity:	EN61000-4-2		
EAC Regulation of Conformity:			

\* Total consumption is sensor consumption plus output and it depends on ambient temperature.

## Mechanical dimensions

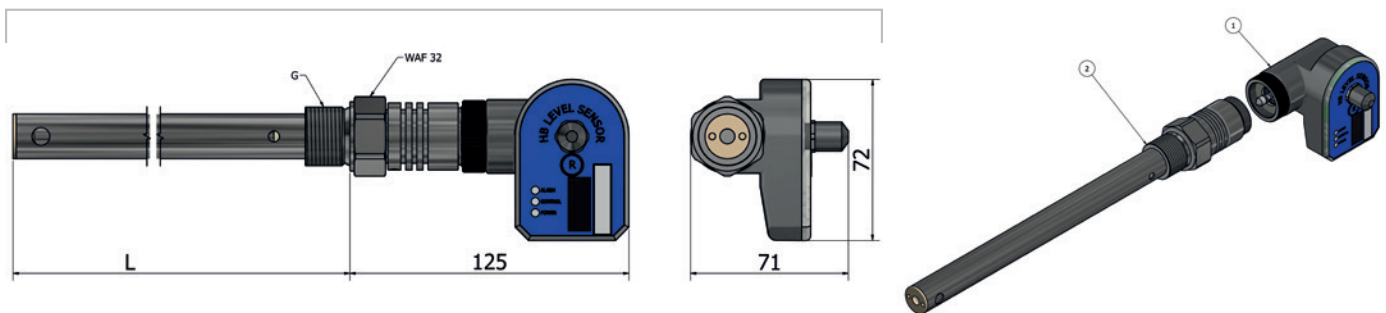

## Ordering code

Length	Length/Thread	Ordering code
200 mm	3/4" NPT	HBLC-OIL-2-2
200 mm	3/4" BSPP	HBLC-OIL-2-6
300 mm	3/4" NPT	HBLC-OIL-3-2
300 mm	3/4" BSPP	HBLC-OIL-3-6
400 mm	3/4" NPT	HBLC-OIL-4-2
400 mm	3/4" BSPP	HBLC-OIL-4-6
500 mm	3/4" NPT	HBLC-OIL-5-2
500 mm	3/4" BSPP	HBLC-OIL-5-6
600 mm	3/4" NPT	HBLC-OIL-6-2
600 mm	3/4" BSPP	HBLC-OIL-6-6
700 mm	3/4" NPT	HBLC-OIL-7-2
700 mm	3/4" BSPP	HBLC-OIL-7-6
800 mm	3/4" NPT	HBLC-OIL-8-2
800 mm	3/4" BSPP	HBLC-OIL-8-6
900 mm	3/4" NPT	HBLC-OIL-9-2
900 mm	3/4" BSPP	HBLC-OIL-9-6
1000 mm	3/4" NPT	HBLC-OIL-10-2
1000 mm	3/4" BSPP	HBLC-OIL-10-6
1100 mm	3/4" NPT	HBLC-OIL-11-2
1100 mm	3/4" BSPP	HBLC-OIL-11-6
1200 mm	3/4" NPT	HBLC-OIL-12-2
1200 mm	3/4" BSPP	HBLC-OIL-12-6
1300 mm	3/4" NPT	HBLC-OIL-13-2
1300 mm	3/4" BSPP	HBLC-OIL-13-6
1400 mm	3/4" NPT	HBLC-OIL-14-2
1400 mm	3/4" BSPP	HBLC-OIL-14-6
1500 mm	3/4" NPT	HBLC-OIL-15-2
1500 mm	3/4" BSPP	HBLC-OIL-15-6
1700 mm	3/4" NPT	HBLC-OIL-17-2
1700 mm	3/4" BSPP	HBLC-OIL-17-6
2000 mm	3/4" NPT	HBLC-OIL-20-2
2000 mm	3/4" BSPP	HBLC-OIL-20-6
2500 mm	3/4" NPT	HBLC-OIL-25-2
2500 mm	3/4" BSPP	HBLC-OIL-25-6
3000 mm	3/4" NPT	HBLC-OIL-30-2
3000 mm	3/4" BSPP	HBLC-OIL-30-6

## Spare parts

Position	Specification	Type	Ordering code
1	Mechanical parts	Mechanical part for HBLC-OIL	HBLC-OIL-XXX-MEK*
2	Electronic part	Electronic part for HBLC-OIL – With LED	HBLC-OIL-EL*

\*When ordering mechanical parts please inform about length- and thread type.

\*Electronic part must be calibrated on-site

# Oil Management Control Switch

Category: HBOC/C

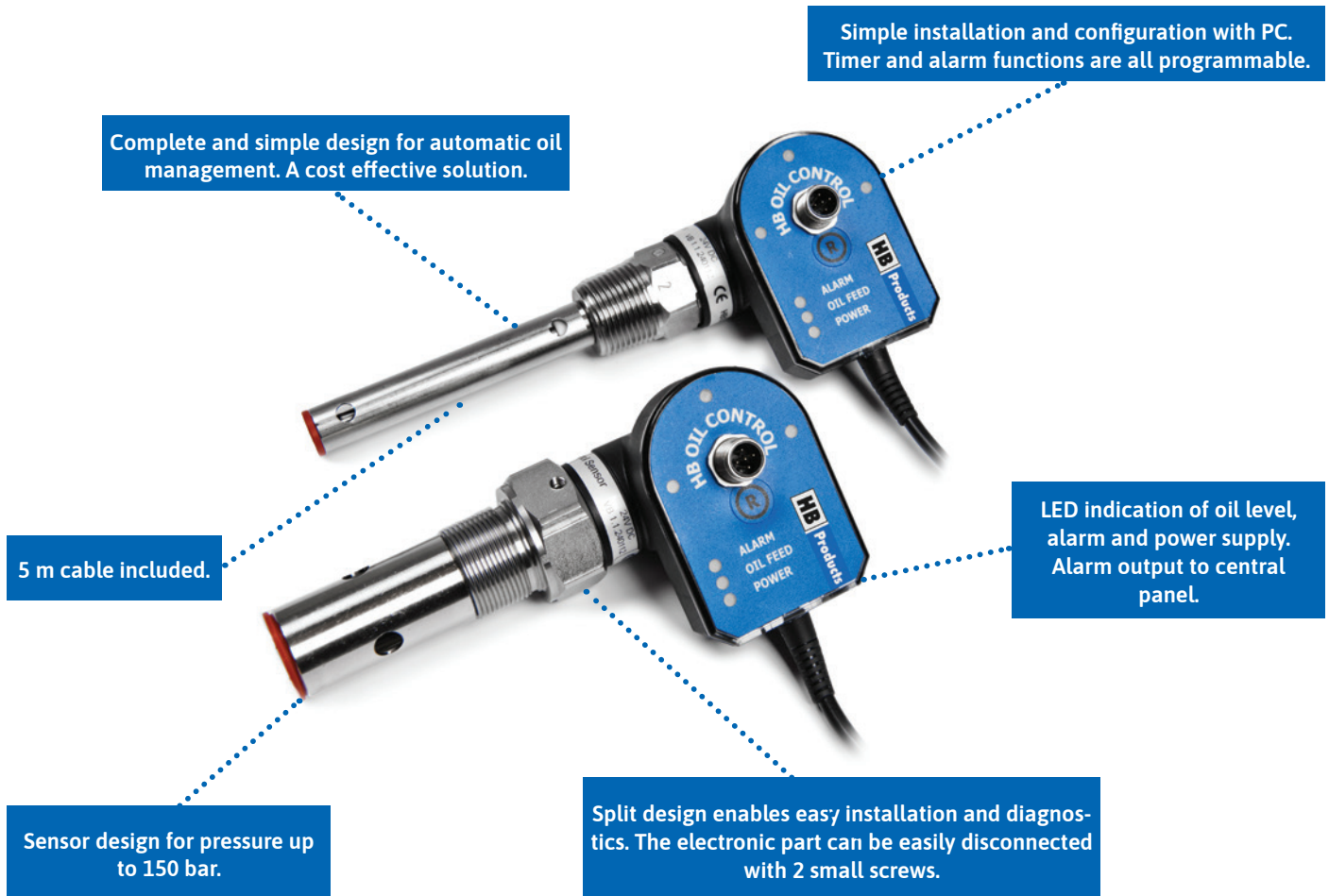

## Functional description:

HBOC/C is an intelligent sensor with a built-in microprocessor. It is designed to detect and control oil levels in oil separators and compressors. Apart from the sensor function, it also has a built-in controller. The controller can be setup with all the parameters that are necessary to directly regulate a solenoid valve for oil level control.

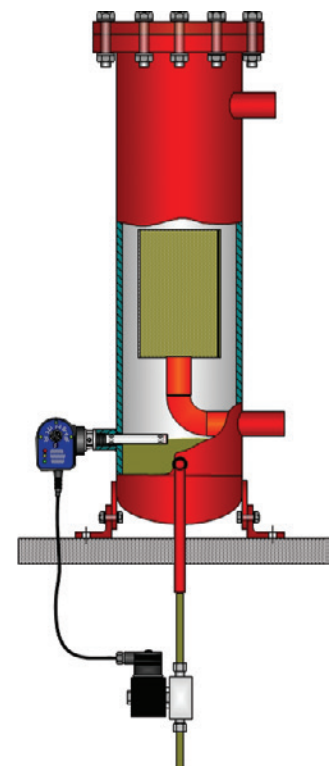

## Technical data - sensor

Power supply		Mechanical specifications	
Voltage	24 V DC + 10%	Thread connection	See ordering code
Current consumption - sensor only*	Max 30 mA	Material - mechanical parts	1/2", 3/4" NPT 3/4" BSPP 1 1/8" UNEF
		Material - electronic parts	Nylon 6 (PA)
Plug connection	M12 - 5 pins DIN 0627	Dimensions	See drawing
Output		Environmental conditions	
Transistor output	PNP/NPN	Ambient temperature	-30...+50°C
Potential-free relay output	Max 1 A (24W)	Oil temperature	0...+80°C
LED Indication	LED (green, yellow, and red)	Max pressure	150 bar
Max. load	24 W	Protection degree	IP65
Cable specification (power supply)		Vibrations	IEC 68-2-6 (4g)
Cable size	3 m - 3 x 0,75 mm <sup>2</sup>	Accessories (To be ordered separately)	
Cable glands	PG7 / M8	Compressor adapter	HBS/ADAP/FLANGE/UNI
Approvals		Programming cable	HBXC-USB
CE	EN 61000-2	Oil Ejector (0,05 l / min)	HBEJ-0.05-G3/8-MK2
Configuration			
Type of configuration	HB Tool		
Tool to be used	HB software		

\* Total consumption is sensor consumption plus output and it depends on ambient temperature.

## Technical data - valve regulation

Valve control	
Signal to valve	ON/OFF
Valve regulation	Time-regulation
Cable specification (valve control)	
Length	3 m (118")
Cable size	3 x 0.75 mm <sup>2</sup>
Cable glands	PG7 / M8

## Mechanical dimensions

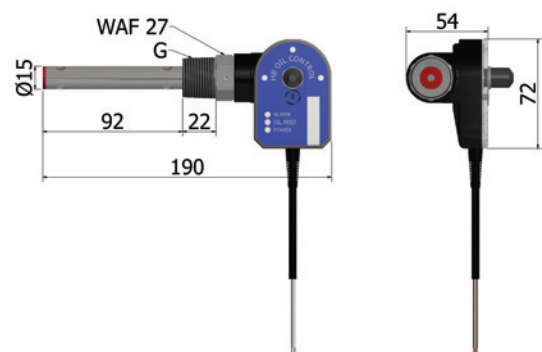

## Ordering codes

House design	Thread type	Ordering code
Angle	1/2" NPT	HBOC/C-1
Angle	3/4" NPT	HBOC/C-2
Angle	3/4" BSPP	HBOC/C-6
Angle	1 1/8" UNEF	HBOC/C-7

## Spare parts

Position	Specification	Type	Ordering code
1	Mechanical parts	1/2" NPT	HBSO1-MEK-1
		3/4" NPT	HBSO1-MEK-2
		3/4" BSPP	HBSO1-MEK-6
		1 1/8 UNEF	HBSO1-MEK-7
2	Electronic part	PC-programmable	HBOC/C-EL





# Oil Pot Controller

Category: HBOR/C-U

Complete and simple design for automatic oil management in oil pots.

Split design which allows for easy installation and diagnostics. The electronic part can be easily disconnected.

Sensor design for pressure up to 150 bar.

5 m m12 cable included.

Simple installation and configuration with PC. Timer and alarm functions are all programmable.

LED indication of oil level, alarm and power supply. Alarm output to central panel.

3 m control cable for solenoid valve (24V DC)



## Functional description:

HBOR/C-U is a level sensor with a built-in controller for controlling the oil return from the oil collection points in industrial cooling systems. The sensor is installed in the oil pot at the level where automatic emptying should take place. When the sensor no longer detects NH<sub>3</sub>, it automatically opens the solenoid valves so that hot gas is fed over an ejector. The ejector forms a vacuum so that the oil pot is automatically emptied. The oil emptying function is set with a HB Tool.

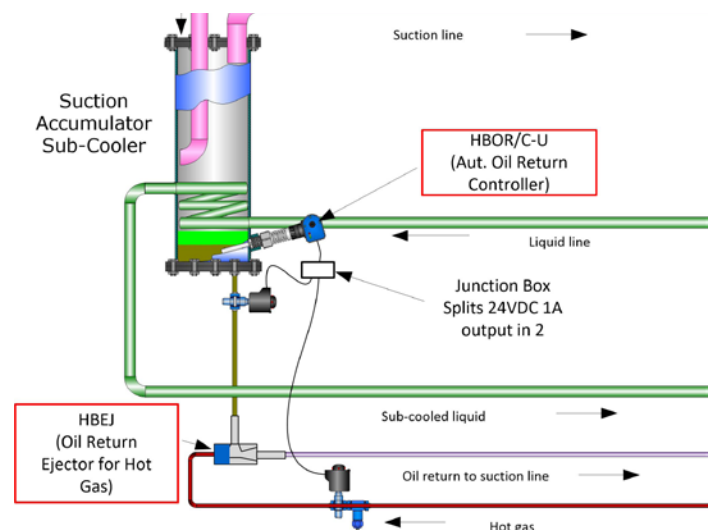

## Technical data - sensor

Power supply		Mechanical specifications	
Voltage	24 V DC + 10%	Thread connection	See ordering code
Current consumption - sensor only*	Max 30 mA	Material - mechanical parts	1/2" & 3/4" NPT/BSPP
Plug connection	M12	Material - electronic parts	Nylon 6 (PA)
		Dimensions	See drawing
Output		Environmental conditions	
On/Off	Time	Ambient temperature	-30...+50°C
Potential-free relay output	Max 1 A (24W)	Oil temperature	-60...+80°C
LED indication	Green, yellow, and red	Max pressure	100 bar
Max. load	Supply voltage, 1A	Protection degree	IP66
<b>Cable specification (power supply)</b>		Vibrations	IEC 68-2-6 (4g)
Cable size	5 m - 3 x 0.25 mm <sup>2</sup>	<b>Accessories</b>	<b>(To be ordered separately)</b>
Cable glands	PG7 / M8	Oil Ejector (0,05 l / min)	HBEJ-0.05-G3/8-MK2
		HBXC-USB	
Approvals			
CE	EN 61000-2		
Configuration			
Type of configuration	PC Tool		
Tool to be used	HB Tool		

\* Total consumption is sensor consumption plus output and it depends on ambient temperature.

## Technical data - valve regulation

Valve control (Modulating valve)	
Signal to valve	ON/OFF
Valve regulation	Time-regulation
Cable specification (valve control)	
Length	3 m (118")
Cable size	3 x 0.75 mm <sup>2</sup>
Cable glands	PG7 / M8

## Ordering codes

Output	Specification	Ordering code
NC / NO*	1/2" NPT	HBOR/C-U-1
NC / NO*	3/4" NPT	HBOR/C-U-2
NC / NO*	1/2" BSPP	HBOR/C-U-5
NC / NO*	3/4" BSPP	HBOR/C-U-6

\*Output can be configured with the HB Tool..

## Spare parts for HBOR-U/C

Position	Specification	Type	Ordering code
1	Mechanical parts	3/4" NPT	HBSR-U-MEK-2
		3/4" BSPP	HBSR-U-MEK-6
2	Electronic part	PC-programmable	HBOR-U/C-EL

## Spare parts for HBOR/C

Position	Specification	Type	Ordering code
2	Electronic part	PC-programmable	HBOR/C-EL

## Mechanical dimensions

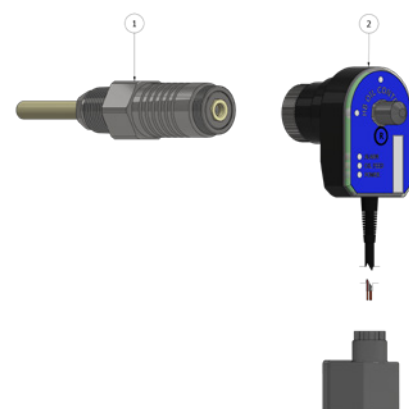
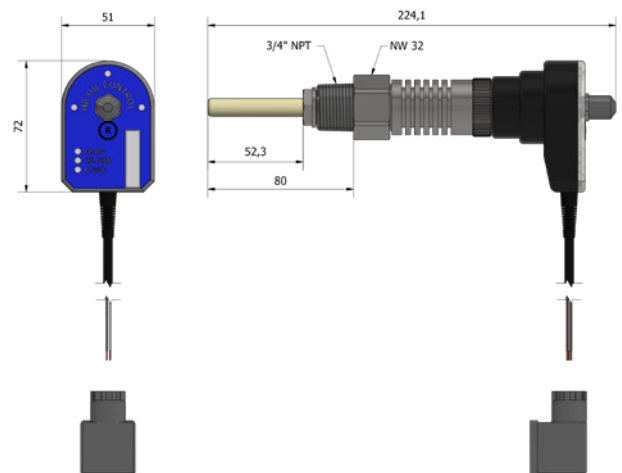

# Oil Ejector

- For oil level control in oil pots

Category: HBEJ-MK2



## Functional description:

HBEJ-MK2 is an oil ejector for automatic oil drainage for industrial ammonia refrigeration systems. The ejector is used together with an HBOR oil pot controller and 2 solenoid valves. The ejector uses hot gas as propellant and is designed for a hot gas pressure until 120 bar. The ejector is made in stainless steel and has compression fittings as well as a thread connection. The ejector is a simple economical solution for transporting oil from point A to point B without worn parts and with a low energy consumption.

The HBEJ oil return ejector can be used on CO<sub>2</sub> system to return the collected oil / refrigerant mixture from the evaporator to the suction line on flooded systems.

The ejector will empty 0,05 l/minute minimum.

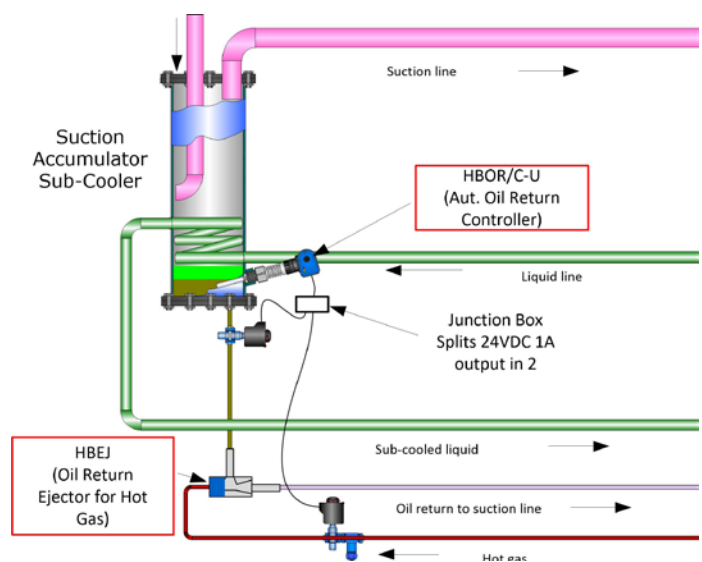

System Design (NH<sub>3</sub> System)

## Mechanical dimensions

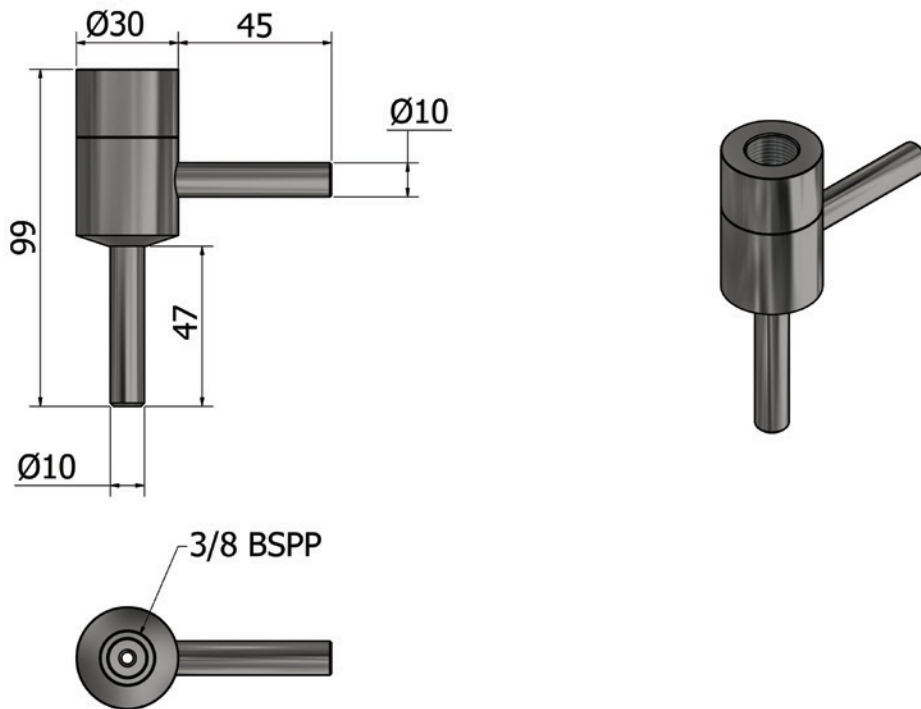

## Technical data

Environmental conditions		Mechanical specifications	
Ambient temperature	-30°C...+50°C	Hot gas connection	3/8" BSPP
Liquid/hot-gas temperature	-60°C...+150°C	Oil return line	10 mm
		Oil inlet	10 mm
Max pressure	Max 120 bar	Material - mechanical parts	AISI304
		Dimensions	See drawing

## Ordering codes

Type	Connection	Ordering code
Oil Ejector (0,05 / min)	3/8" BSPP / $\text{Ø}10$ / $\text{Ø}10$	HBEJ-0.05-G3/8-MK2



# Sensors for Heat Pumps

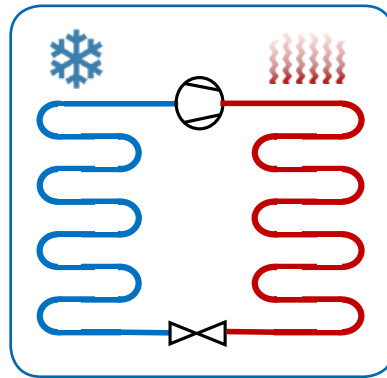

## Switches and Sensors for Heat Pump applications

### Sensors and Switches

<b>Function:</b>	<b>NH<sub>3</sub> Level Sensor for Heat Pump Applications</b>
<b>Application:</b>	Level measurement in standpipes
<b>Refrigerant Temperature:</b>	-60...+80°C
<b>Supply:</b>	24 V AC/DC
<b>Output:</b>	4-20 mA

[Page 159](#)

<b>Function:</b>	<b>High Temperature Oil Switch - 24 V AC/DC</b>
<b>Applications:</b>	Compressor crankcases, oil collectors/tanks & oil separators.
<b>Oil Temperature:</b>	0...145 °C
<b>Supply:</b>	24 V AC/DC
<b>Output:</b>	Solid state relay

[Page 163](#)

# NH<sub>3</sub> Liquid Level Sensor for Heat Pump Applications

- Level measurement in standpipes

Category: HBLT-A3 & HBSLT-A3

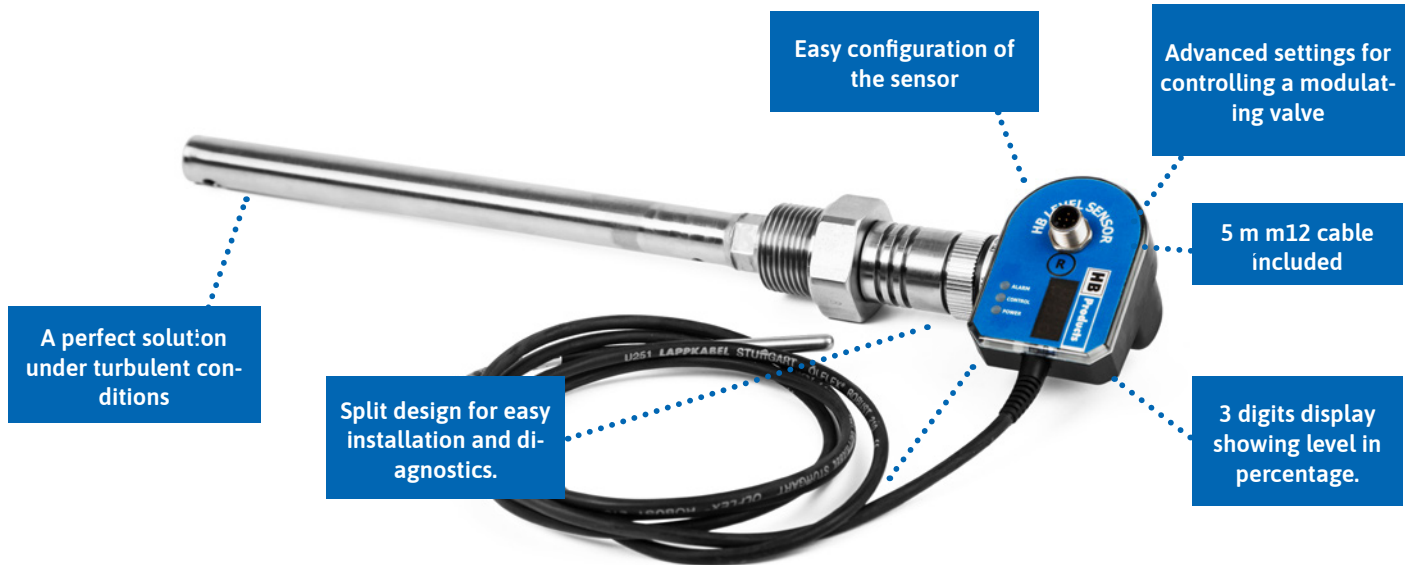

## Functional description:

HBLT-A3 for heat pump applications.

HBLT-A3 capacitive liquid level transmitters are used to measure liquid levels in refrigerant vessels. The sensor transmits a current signal from 4 to 20 mA (4 mA when the transmitter does not register liquid - and 20 mA when the entire transmitter is surrounded by liquid).

The difference between the new HBLT-A3, HBLT-A2 and the first version HBLT-A1 is the mechanical design. HBLT-A3 is more compact making it stable at higher temperatures.

HBLT-A3 is an intelligent sensor with a built-in microprocessor and it has the same digital display as the HBLT-A2. It emits a 4-20 mA signal, which is proportional to the sensor's preset range of measurement. Apart from the 4-20 mA signal the sensor also has a built-in controller. The controller can be configured with all the parameters necessary for controlling a modulating motor valve. The sensor can be delivered with a cable for direct supply to and control of motor valve.

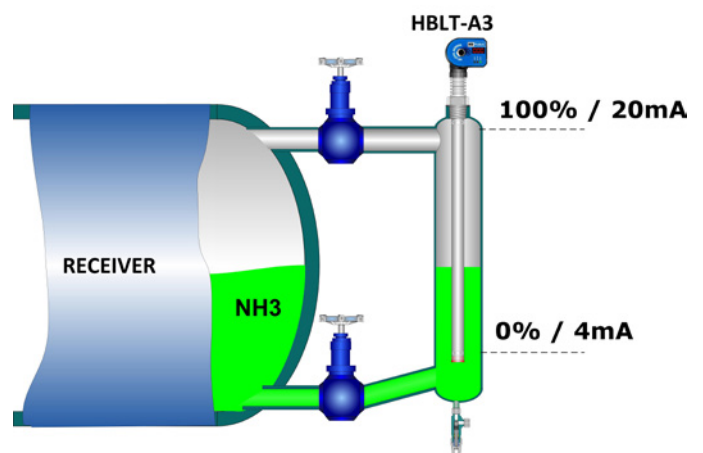

## Technical data

Power supply		Mechanical specifications	
Voltage	24 V AC/DC $\pm$ 10 % *	Thread connections	3/4" NPT / BSPP
Plug connection	M12, 5 pins - DIN 0627	Material - mechanical parts	AISI304 / PTFE
Current consumption - sensor only*	250 mA	Material - electronic parts	Nylon 6 (PA)
		House type	Angle
Output		Configuration & indication	
Analog output	4-20 mA	Configuration	By HB Tool and USB-cable
		LED indication	Green, yellow, and red
Environmental conditions		Approvals	
Ambient temperature	-30...+50°C	EMC test	EN61000-2
Refrigerant temperature	-60...+145°C		
Max. pressure	100 bar		
Protection class	IP65		
Vibrations	IEC 68-2-6 (4g)		

\* Total consumption is sensor consumption plus output and it depends on ambient temperature.



## Ordering codes

Length	Thread type	Without cable	Modulating valve*	Stepper motor**	Pulse width modulation
200 mm	3/4" BSPP	HBLT-A3-2-6	HBSLT/C-A3-2-6	HBSLT/S-A3-2-6	HBSLT/PWM-A3-2-6
300 mm	3/4" BSPP	HBLT-A3-3-6	HBSLT/C-A3-3-6	HBSLT/S-A3-3-6	HBSLT/PWM-A3-3-6
400 mm	3/4" BSPP	HBLT-A3-4-6	HBSLT/C-A3-4-6	HBSLT/S-A3-4-6	HBSLT/PWM-A3-4-6
500 mm	3/4" BSPP	HBLT-A3-5-6	HBSLT/C-A3-5-6	HBSLT/S-A3-5-6	HBSLT/PWM-A3-5-6
600 mm	3/4" BSPP	HBLT-A3-6-6	HBSLT/C-A3-6-6	HBSLT/S-A3-6-6	HBSLT/PWM-A3-6-6
700 mm	3/4" BSPP	HBLT-A3-7-6	HBSLT/C-A3-7-6	HBSLT/S-A3-7-6	HBSLT/PWM-A3-7-6
800 mm	3/4" BSPP	HBLT-A3-8-6	HBSLT/C-A3-8-6	HBSLT/S-A3-8-6	HBSLT/PWM-A3-8-6
900 mm	3/4" BSPP	HBLT-A3-9-6	HBSLT/C-A3-9-6	HBSLT/S-A3-9-6	HBSLT/PWM-A3-9-6
1000 mm	3/4" BSPP	HBLT-A3-10-6	HBSLT/C-A3-10-6	HBSLT/S-A3-10-6	HBSLT/PWM-A3-10-6
1100 mm	3/4" BSPP	HBLT-A3-11-6	HBSLT/C-A3-11-6	HBSLT/S-A3-11-6	HBSLT/PWM-A3-11-6
1200 mm	3/4" BSPP	HBLT-A3-12-6	HBSLT/C-A3-12-6	HBSLT/S-A3-12-6	HBSLT/PWM-A3-12-6
1300 mm	3/4" BSPP	HBLT-A3-13-6	HBSLT/C-A3-13-6	HBSLT/S-A3-13-6	HBSLT/PWM-A3-13-6
1400 mm	3/4" BSPP	HBLT-A3-14-6	HBSLT/C-A3-14-6	HBSLT/S-A3-14-6	HBSLT/PWM-A3-14-6
1500 mm	3/4" BSPP	HBLT-A3-15-6	HBSLT/C-A3-15-6	HBSLT/S-A3-15-6	HBSLT/PWM-A3-15-6
1700 mm	3/4" BSPP	HBLT-A3-17-6	HBSLT/C-A3-17-6	HBSLT/S-A3-17-6	HBSLT/PWM-A3-17-6
2500 mm	3/4" BSPP	HBLT-A3-25-6	HBSLT/C-A3-25-6	HBSLT/S-A3-25-6	HBSLT/PWM-A3-25-6
3000 mm	3/4" BSPP	HBLT-A3-30-6	HBSLT/C-A3-30-6	HBSLT/S-A3-30-6	HBSLT/PWM-A3-30-6
200 mm	3/4" NPT	HBLT-A3-2-2	HBSLT/C-A3-2-2	HBSLT/S-A3-2-2	HBSLT/PWM-A3-2-2
300 mm	3/4" NPT	HBLT-A3-3-2	HBSLT/C-A3-3-2	HBSLT/S-A3-3-2	HBSLT/PWM-A3-3-2
400 mm	3/4" NPT	HBLT-A3-4-2	HBSLT/C-A3-4-2	HBSLT/S-A3-4-2	HBSLT/PWM-A3-4-2
500 mm	3/4" NPT	HBLT-A3-5-2	HBSLT/C-A3-5-2	HBSLT/S-A3-5-2	HBSLT/PWM-A3-5-2
600 mm	3/4" NPT	HBLT-A3-6-2	HBSLT/C-A3-6-2	HBSLT/S-A3-6-2	HBSLT/PWM-A3-6-2
700 mm	3/4" NPT	HBLT-A3-7-2	HBSLT/C-A3-7-2	HBSLT/S-A3-7-2	HBSLT/PWM-A3-7-2
800 mm	3/4" NPT	HBLT-A3-8-2	HBSLT/C-A3-8-2	HBSLT/S-A3-8-2	HBSLT/PWM-A3-8-2
900 mm	3/4" NPT	HBLT-A3-9-2	HBSLT/C-A3-9-2	HBSLT/S-A3-9-2	HBSLT/PWM-A3-9-2
1000 mm	3/4" NPT	HBLT-A3-10-2	HBSLT/C-A3-10-2	HBSLT/S-A3-10-2	HBSLT/PWM-A3-10-2
1100 mm	3/4" NPT	HBLT-A3-11-2	HBSLT/C-A3-11-2	HBSLT/S-A3-11-2	HBSLT/PWM-A3-11-2
1200 mm	3/4" NPT	HBLT-A3-12-2	HBSLT/C-A3-12-2	HBSLT/S-A3-12-2	HBSLT/PWM-A3-12-2
1300 mm	3/4" NPT	HBLT-A3-13-2	HBSLT/C-A3-13-2	HBSLT/S-A3-13-2	HBSLT/PWM-A3-13-2
1400 mm	3/4" NPT	HBLT-A3-14-2	HBSLT/C-A3-14-2	HBSLT/S-A3-14-2	HBSLT/PWM-A3-14-2
1500 mm	3/4" NPT	HBLT-A3-15-2	HBSLT/C-A3-15-2	HBSLT/S-A3-15-2	HBSLT/PWM-A3-15-2
1700 mm	3/4" NPT	HBLT-A3-17-2	HBSLT/C-A3-17-2	HBSLT/S-A3-17-2	HBSLT/PWM-A3-17-2
2500 mm	3/4" NPT	HBLT-A3-25-2	HBSLT/C-A3-25-2	HBSLT/S-A3-25-2	HBSLT/PWM-A3-25-2
3000 mm	3/4" NPT	HBLT-A3-30-2	HBSLT/C-A3-30-2	HBSLT/S-A3-30-2	HBSLT/PWM-A3-30-2

\*For direct control of a modulating valve such as Siemens MVS661

\*\*For direct control of a stepper motor valve such as Carel

## Mechanical dimensions

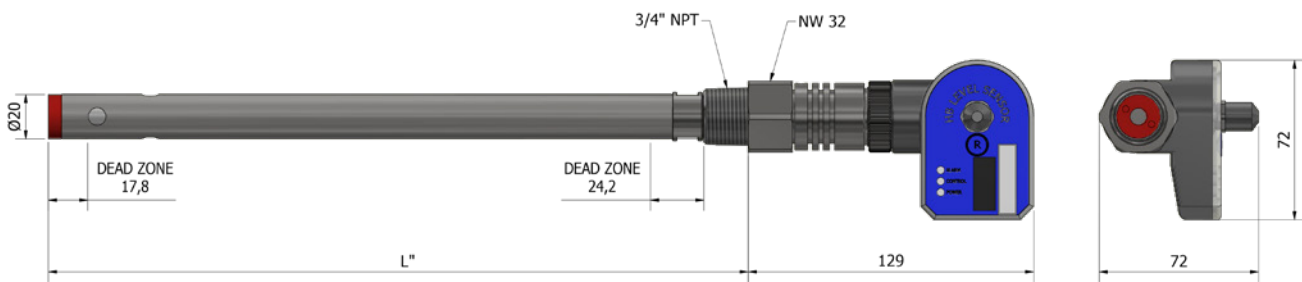
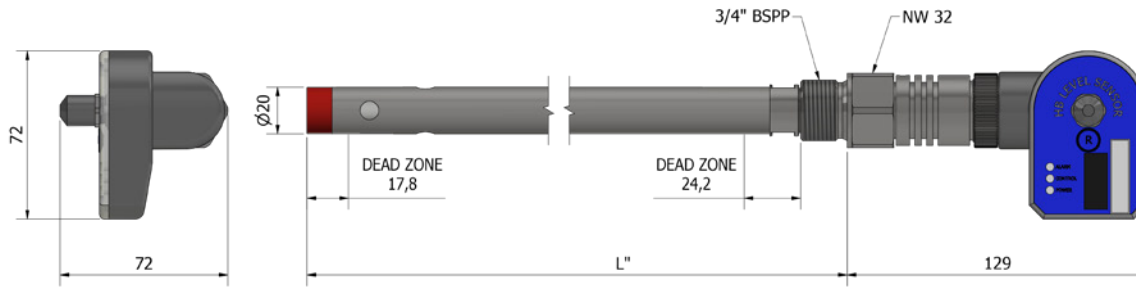

## Spare parts



Specification	Length	Thread type	Ordering code
Electronic parts			HBLT-A3-EL
For modulating valve			HBLT/C-A3-EL
For stepper motor			HBLT/S-A3-EL
For Pulse width modulation			HBLT/PWM-A3-EL

# High Temperature Oil Switch - 24 V AC/DC

Category: HBSO-SSR-1/xx-x/HT

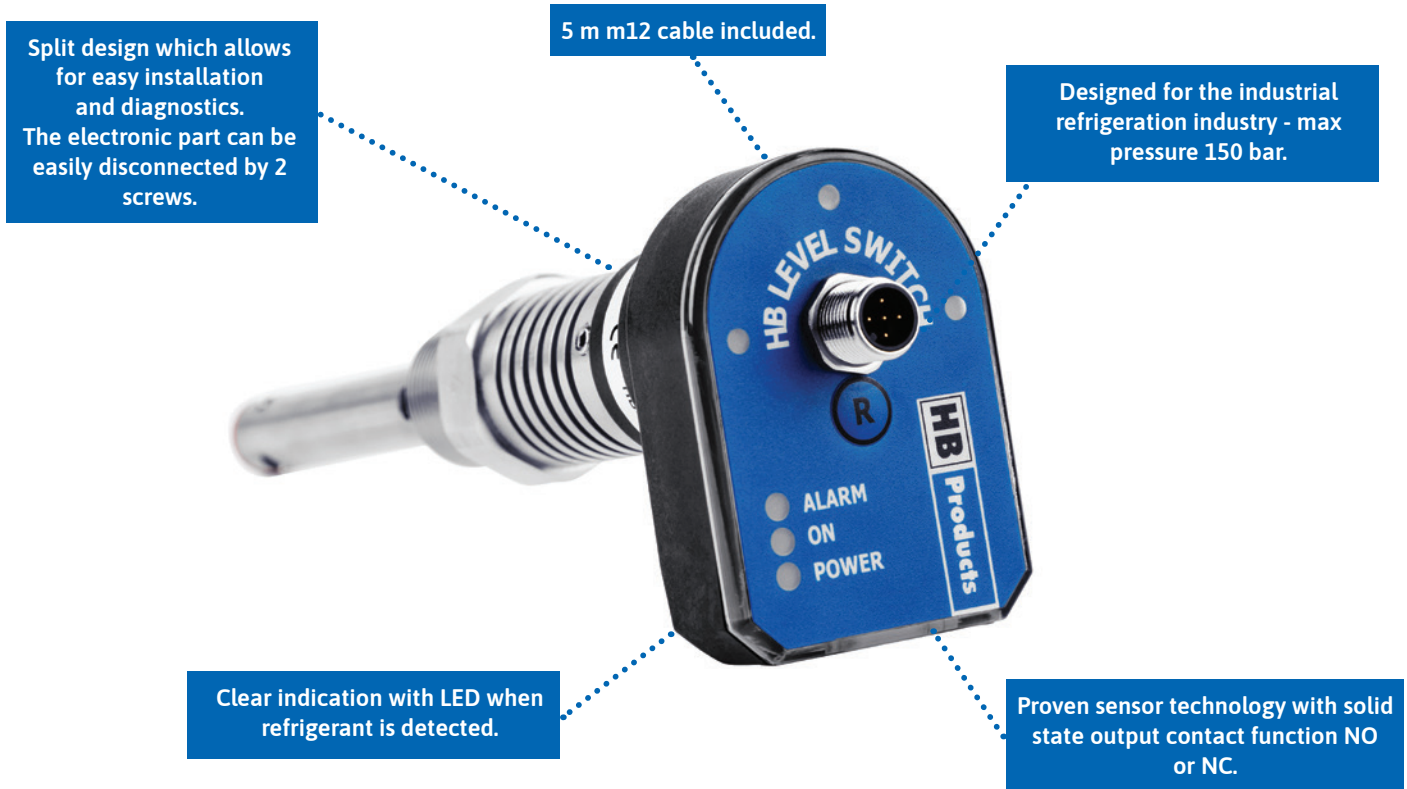

## Functional description:

HBSO-SSR-1/XX-X-HT is a high temperature level switch for detecting common lubricating oils in refrigeration systems. The level switch is used for all oil types (PAO, POE, mineral oil and PAG oil). Typically it is installed in/on the compressor and the oil separator, but it is also suited for installation in other locations in the oil system. The sensor's measurement principle makes it unique for these purposes, since the properties of the measurement principle allows it, among other things, to detect oil without detecting refrigerant. It is calibrated so that it is unaffected by oil spray and only allows a small amount of foam. The sensor is also constructed to resist high pressure and temperatures.

The sensor is suited for use on transcritical CO<sub>2</sub> refrigeration systems.

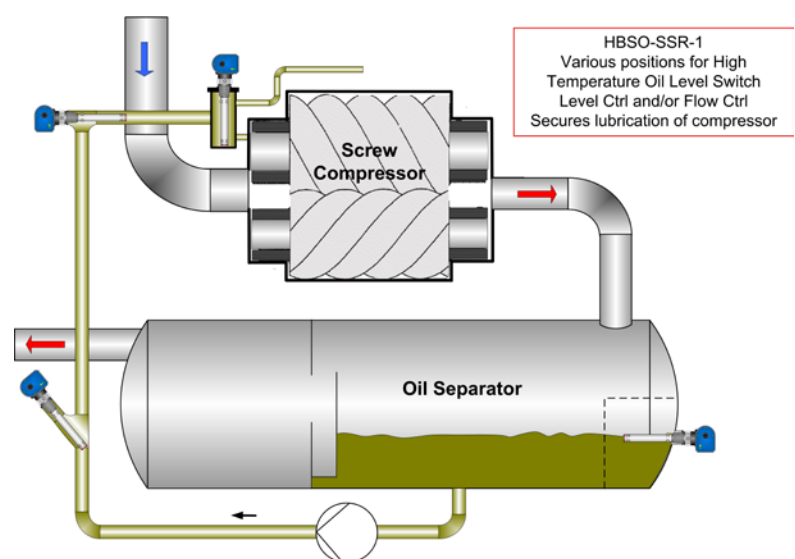

## Technical data

Power supply		Mechanical specifications	
Voltage	24 V AC/DC	Thread connection	½", ¾" NPT / BSPP and 1 1/8" UNEF
Current consumption - sensor only*	30 mA	Material - mechanical parts	AISI 304 / PTFE
		Material - electronic parts	Nylon 6 (PA)
Plug connection	M12 - DIN 0627	Dimensions	See drawing
Output		Environmental conditions	
Output type	Solid state relay - 40W	Ambient temperature	-30...+50°C
Output function	NC or NO	Oil temperature	0...+145°C
LED indication		Max pressure	150 bar
Level indication	3 x LED (green)	Protection degree	IP54
Power supply	1 x LED (green)	Vibrations	IEC 68-2-6 (4g)
Relay-on activation	1 x LED (yellow)	Oil type	
Alarm	1 x LED (red)	HBSO	PAO, POE, PAG & Mineral
Cable specification (power supply)			
Cable size	5m - 3 x 0.25 mm <sup>2</sup>		
Cable resistance	500 Ω/Km		
Approvals			
CE	EN 61000-2		

\* Total consumption is sensor consumption plus output and it depends on ambient temperature.

## Mechanical dimensions

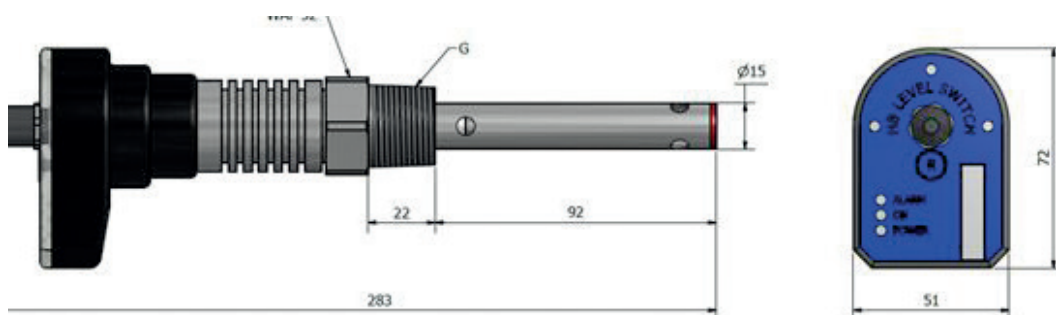

## Ordering codes

Output	Thread type (G)	Oil type	Temperature	Ordering code
NO	1/2" NPT	All types	0...145 °C	HBSO-SSR-1/NO-1/HT
NO	3/4" NPT	All types	0...145 °C	HBSO-SSR-1/NO-2/HT
NO	1/2" BSPP	All types	0...145 °C	HBSO-SSR-1/NO-5/HT
NO	3/4" BSPP	All types	0...145 °C	HBSO-SSR-1/NO-6/HT
NO	1 1/8" UNEF	All types	0...145 °C	HBSO-SSR-1/NO-7/HT
NC	1/2" NPT	All types	0...145 °C	HBSO-SSR-1/NC-1/HT
NC	3/4" NPT	All types	0...145 °C	HBSO-SSR-1/NC-2/HT
NC	1/2" BSPP	All types	0...145 °C	HBSO-SSR-1/NC-5/HT
NC	3/4" BSPP	All types	0...145 °C	HBSO-SSR-1/NC-6/HT
NC	1 1/8" UNEF	All types	0...145 °C	HBSO-SSR-1/NC-7/HT

## Spare parts

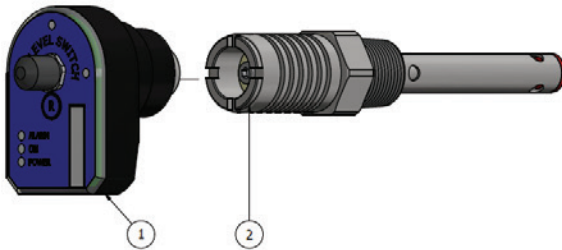

Position	Specification	Type	Ordering code
1	Electronic parts	NO	HBSO-SSR-1/NO-EL/HT
		NC	HBSO-SSR-1/NC-EL/HT
2	Mechanical parts	1/2" NPT	HBSO-MEK-1/HT
		3/4" NPT	HBSO-MEK-2/HT
		1/2" BSPP	HBSO-MEK-5/HT
		3/4" BSPP	HBSO-MEK-6/HT
		1 1/8" UNEF	HBSO-MEK-7/HT



## Defrost, Temperature & Pressure



# Switches and Sensors for Industrial Refrigeration Installations

Sensors and Controllers			
Ice	<p><b>Function:</b> Defrost Sensor MK-2</p> <p>Applications: Evaporator - Defrost on demand.</p> <p>Supply: 24 V AC/DC</p> <p>Output: 4...20 mA</p>		<a href="#">Page 168</a>
Ice	<p><b>Function:</b> Ice Bank Sensor</p> <p>Applications: Ice thickness gauge for ice banks.</p> <p>Supply: 24 V AC/DC</p> <p>Output: 4...20 mA</p>		<a href="#">Page 172</a>
	<p><b>Function:</b> Temperature Sensor</p> <p>Applications: Temperature measurement in refrigeration systems</p> <p>Refrigerant Temperature: -50...+130°C</p> <p>Output: PT100 / PT1000</p>		<a href="#">Page 173</a>
	<p><b>Function:</b> Temperature Transmitter/Sensor</p> <p>Applications: Temperature measurement in refrigeration systems</p> <p>Refrigerant Temperature: -50...+130°C</p> <p>Output: 4...20 mA</p>		<a href="#">Page 175</a>
	<p><b>Function:</b> Cable Temperature Sensor</p> <p>Applications: Temperature measurement in refrigeration systems</p> <p>Temperature range: -40...+130°C (peak 150°C)</p> <p>Output: PT100 / PT 1000</p>		<a href="#">Page 177</a>
	<p><b>Function:</b> Wall Mounted Temperature Sensor with Transmitter</p> <p>Applications: Temperature measurement in refrigeration systems</p> <p>Temperature range: -40...+130°C (peak 150°C)</p> <p>Output: PT 1000</p>		<a href="#">Page 178</a>
	<p><b>Function:</b> Pressure Sensor</p> <p>Applications: Pressure measurement in refrigeration systems</p> <p>Refrigerant Temperature: -40...+125°C</p> <p>Supply: 9.32 V DC</p> <p>Output: 4...20 mA</p>		<a href="#">Page 180</a>

# Defrost Sensor MK-2

Defrost system including temperature sensor (PT1000)

**Category: HBDF-MK2**



## Functional description:

HBDF-MK2 is a unique, but easily adaptable solution for automatic defrosting of evaporators. Optimal defrosting results in energy savings and increased freezing capacity. Experiences from existing installations have shown that it can easily save up to 40% of energy and thereby fast return your investment.

The sensor measures the thickness of ice built up between the fins and emits a 4-20mA or digital ON/OFF signal to the control systems. A temperature sensor (PT1000) is located at the fins, near the bottom part of the evaporator.

It senses when defrost is completed and stops the sequence. The defrost sensors are based on the capacitive measuring principle, in which an insulated steel wire acts as one conductor and the evaporator fins and tubes act as the second conductor. Together they make up a viable electrical capacitor.

Changes in the measured signal occur when ice is built up between the fins, as the sensor measures the dielectric difference between the air and ice.

The sensor can be installed in less than one hour, on both new and old evaporators. It can even be installed when the system is in operation, hence shutdown is not necessary. The electronic part is mounted on the evaporator's frame by using 2-4 screws. The mechanical part consists of a thin PA12 or PTFE-coated wire, which is mounted between the fins of the evaporator in their inlet side with special HB Snap-On clips or standard nylon cable ties. The HBDF-MK2 sensor is available in 3 versions, with a 10-, 20-, and 30 meter wire and as standard, Low Temperature (LT) or Heat Pump-version (RS).

After the installation, the sensor should be calibrated/configured to the evaporator by using the HB-TOOL (PC-based software tool), which can be downloaded from our web-site.

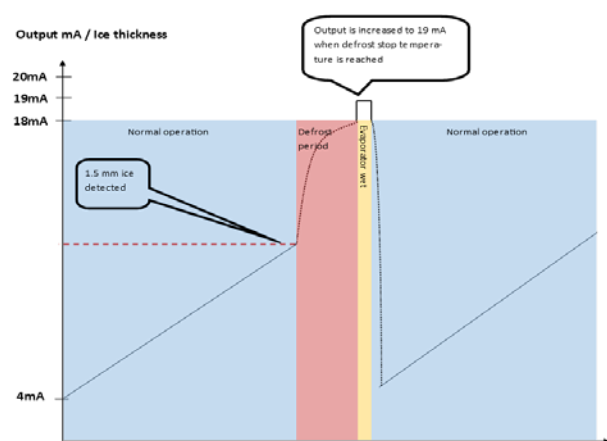

Graphical view of a typical sequence on an air cooler

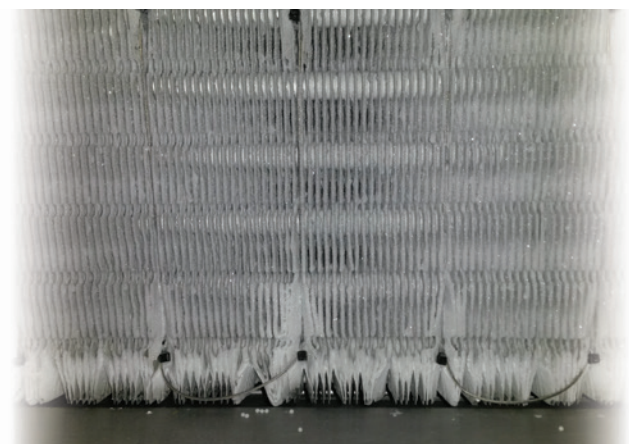



## Technical data

Power supply		Mechanical specifications	
Voltage	24 V AC/DC		
Current consumption - sensor only*	600 mA	<b>Material – mechanical parts</b>	AISI 316L
Electrical connection	Screw terminals	<b>Material – electronic parts</b>	Nylon 6 (PA)
Sensor design	3-wire		
Analog output	4-20 mA		
Max. load	500 ohm	Installation conditions	
Relay output	2x5A, NO/NC	<b>Ambient temperature</b>	-30...+50°C
Relay output 24V	2x3A, NO/NC	<b>Protection degree</b>	IP65
Cable entry:	PG9 / M12	<b>Vibrations</b>	IEC 68-2-6 (4g)
Approvals		Accessories	
EMC Emission	EN61000-3-2	Supply cable, 5 meters	HBxC-M12/5 Straight
EMC Immunity	EN61000-4-2	USB Programming cable	HBxC-USB
Configuration			
Type of configuration	HB Tool		
Tool to be used	HB software		

\* Total consumption is sensor consumption plus output and it depends on ambient temperature.

## Ordering codes

Sensor type	Wire length	Temperature Sensor Length	Ordering code
Defrost sensor MK2	10 m	2 m	HBDF-MK2-10
Defrost sensor MK2	20 m	2 m	HBDF-MK2-20
Defrost sensor MK2	30 m	2 m	HBDF-MK2-30
Low temperature defrost sensor MK2	10 m	2 m	HBDF-MK2-10-LT
Low temperature defrost sensor MK2	20 m	2 m	HBDF-MK2-20-LT
Low temperature defrost sensor MK2	30 m	2 m	HBDF-MK2-30-LT
Defrost sensor for heat pump applications	10 m	2 m	HBDF-MK2-10-RS
Defrost sensor for heat pump applications	20 m	2 m	HBDF-MK2-20-RS
Defrost sensor for heat pump applications	30 m	2 m	HBDF-MK2-30-RS

## Application example

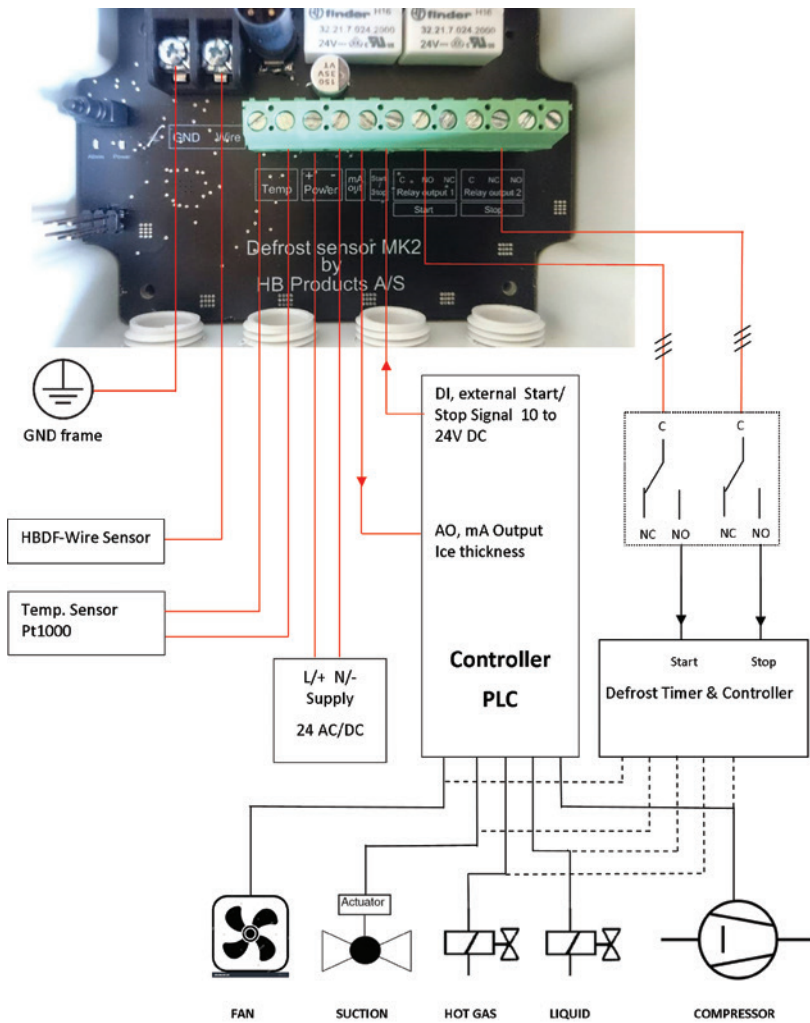

## Output

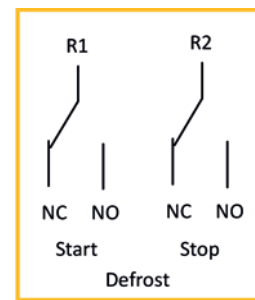

2 x relay  
1 x mA  
Ice thickness

### Safety:

Defrosting with hot gas must be performed in a safe way in order to ensure that there is no risk for liquid hammering and leakage of refrigerant.

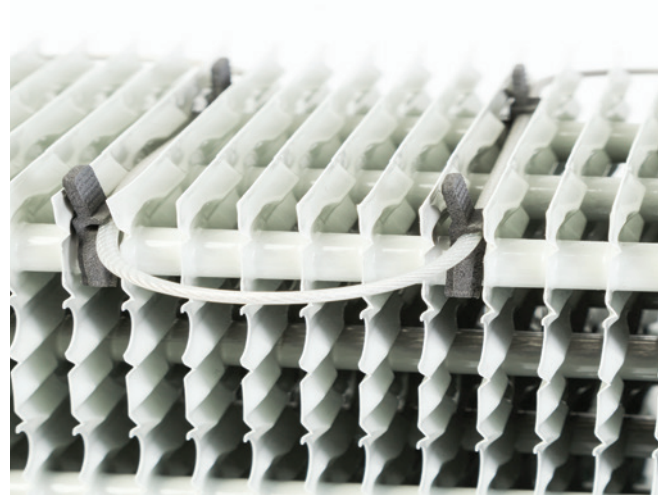
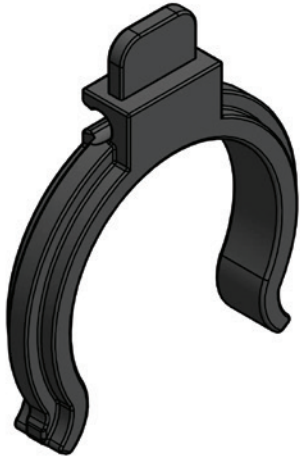

HBDF-SnapON Clips for mounting of HBDF wire probe.  
To be ordered separately.  
HBDF-SnapON Clips are sold in bags of 25 or 50 pieces

**Accessories**

Tube dimension	Quantity	Ordering code
8 - 10 mm	25	HBDF-SnapONClip8-25
8 - 10 mm	50	HBDF-SnapONClip8-50
10 - 12 mm	25	HBDF-SnapONClip10-25
10 - 12 mm	50	HBDF-SnapONClip10-50
12 - 14 mm	25	HBDF-SnapONClip12-25
12 - 14 mm	50	HBDF-SnapONClip12-50
14 - 16 mm	25	HBDF-SnapONClip14-25
14 - 16 mm	50	HBDF-SnapONClip14-50
16 - 18 mm	25	HBDF-SnapONClip16-25
16 - 18 mm	50	HBDF-SnapONClip16-50
19 - 22 mm	25	HBDF-SnapONClip19-25
19 - 22 mm	50	HBDF-SnapONClip19-50
22 - 25 mm	25	HBDF-SnapONClip22-25
22 - 25 mm	50	HBDF-SnapONClip22-50
USB Programming cable		HBxC-USB



**Spare parts**

Position	Designation	Specification	Ordering code
1	Mechanical part	10 m wire	HBDF-MK2-Wire-10
	Mechanical part	20 m wire	HBDF-MK2-Wire-20
	Mechanical part	30 m wire	HBDF-MK2-Wire-30
2	Electronic part	PCB	HBDF-MK2-EL
	Electronic part	PCB - Electronic part for the first version	HBDF-EL
3	Temp. Cable sensor	Pt1000-Cable type	HBTS-PT1000/Cable-2M



# Ice Bank Sensor

Category: HBIB



New

## Functional description:

Ice bank sensor able to measure the ice formation between two steel wires. It is able to measure up to 100 mm ice.

The sensor has been tested under laboratory conditions only, but the sensor is built upon the defrost sensor which is in operation by many customers. We are looking for new customers interested in testing the product. A product description is available on our website.

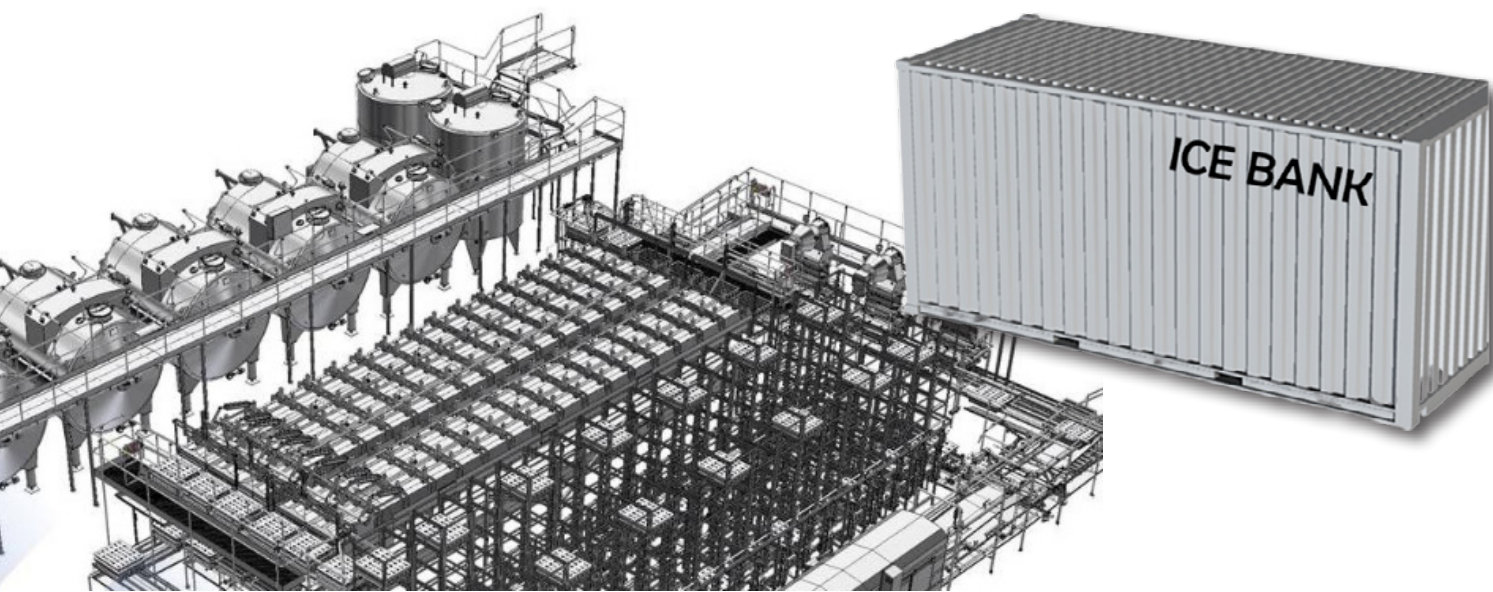

# Temperature Sensor

## Category: HBTS

4-wire PT100 or PT1000 sensor element DIN B class 1/3 - DIN 60751.

M12 plug connection - DIN 0627.

Temperature area: -50..+130°C.

Refrigeration industry design - max pressure 150 bar.



### Functional description:

HBTS is a temperature sensor in accordance with DIN 60751, and it is available in two variants, PT100 and PT1000 – DIN B – class 3. The sensor is designed for the refrigeration industry where servicing of the electronics can be carried out without emptying the system of refrigerant. The sensor is delivered with a 60 & 90 mm sensor element length and a 6 mm sensor diameter.

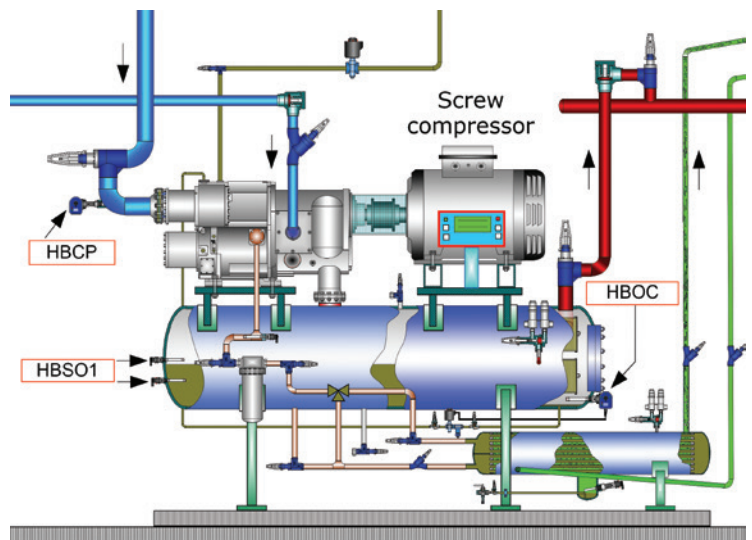

## Technical data

Electrical specifications		Mechanical specifications	
Connector	M12 - DIN 0627	Thread connection	1/4" NPT or BSPP
Sensor element	PT100 / PT1000	Material - mechanical parts	AISI 304
Sensor class	DIN B - KL 1/3	Material - electronic parts	Plastic
Sensor design	4 wire	Sensor element	Ø6 - 60 / 90 mm
Environmental conditions		Approvals	
Ambient temperature	-30...+85°C	EMC	EN 61000-2
Refrigerant temperature	-50...+130°C	Accessories	
Max pressure	150 bar	Cable-5m	HBxC/M12-5
Protection degree	IP67		
Vibrations	IEC 68-2-6 (4g)		

## Mechanical dimensions

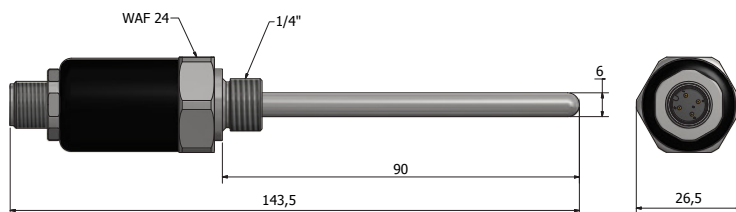
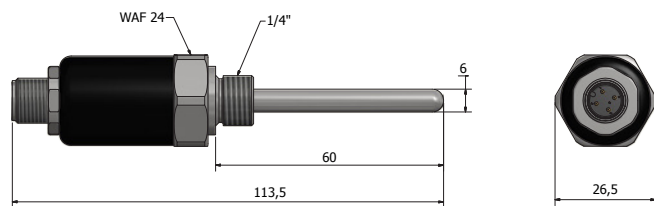

## Ordering codes

Sensor type	Sensor length	Thread type	Ordering code
PT100	60 mm	1/4" NPT	HBTS-PT100/NPT/60
PT100	90 mm	1/4" NPT	HBTS-PT100/NPT/90
PT100	60 mm	1/4" BSPP	HBTS-PT100/BSP/60
PT100	90 mm	1/4" BSPP	HBTS-PT100/BSP/90
PT1000	60 mm	1/4" NPT	HBTS-PT1000/NPT/60
PT1000	90 mm	1/4" NPT	HBTS-PT1000/NPT/90
PT1000	60 mm	1/4" BSPP	HBTS-PT1000/BSP/60
PT1000	90 mm	1/4" BSPP	HBTS-PT1000/BSP/90

# Temperature Transmitter/PT 1000 Sensor

With 4-20mA output for temperature measurement in a sensor pocket inside a refrigeration system

Category: HBTS-TR

Designed for the industrial refrigeration industry - max pressure 150 bar.



Proven sensor technology with 4-20mA output.

The sensor is mounted in a sensor well and can be replaced without evacuating the system.

## Functional description:

HBTS-TR is a temperature sensor conforming to DIN 60751, with 4-20mA transmitter signal, the measuring range can be scaled with the HB-TOOL. The sensor can be configured with the HBxC-USB programming cable and the adapter HBxC-Adapt-DIN/M12 which can be purchased as accessories.

The sensor is designed for the refrigeration industry where servicing of the electronics can be carried out without emptying refrigerant from the system.

The sensor is delivered with a 60 & 90 mm sensor element length and a 6 mm sensor diameter. Sensor well and ISO 4400/DIN 43650 plug is included with the sensor.

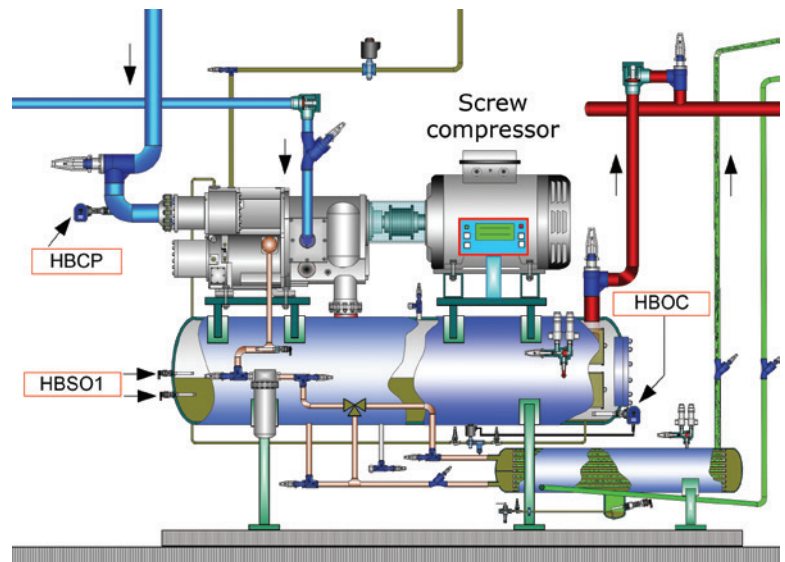

## Technical data

Electrical specifications		Mechanical specifications	
Plug	DIN 43 650 MV PLUG	Thread connection	1/4" NPT or BSPP
Sensor element	PT100 / PT1000	Material – mechanical parts	AISI 304
Sensor class	DIN B - CL. 1/3 (PT 1000)	Material – electronic parts	Plastic
Sensor design	3 wire	Sensor element	Ø6 - 60 / 90 mm
Environmental conditions		Approvals	
Ambient temperature	-30...50°C	EMC Emission	EN61000-3-2
Refrigerant temperature	-50...+130°C	EMC Immunity	EN61000-4-2
Max pressure	150 bar		
Protection degree	IP65		
Vibrations	IEC 68-2-6 (4g)		

## Ordering codes

Sensor type	Length of sensor pocket	Thread type	Ordering code
PT 1000	60 mm	1/4" BSPP	HBTS-TR/PT1000/BSP60
PT 1000	90 mm	1/4" BSPP	HBTS-TR/PT1000/BSP90
PT 1000	60 mm	1/4" NPT	HBTS-TR/PT1000/NPT60
PT 1000	90 mm	1/4" NPT	HBTS-TR/PT1000/NPT90

## Electrical installations

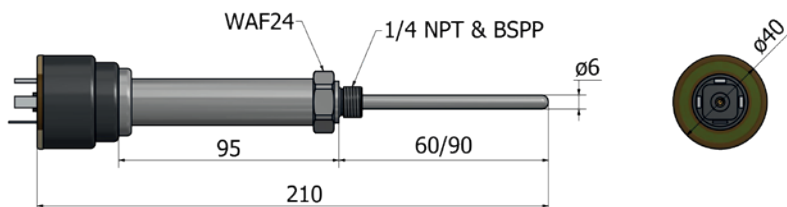

## Spare parts

Complete part no.	Length of sensor pocket	Spare electronic
HBTS-TR/PT1000/BSP/60	60 mm	HBTS-TR/PT1000/60-EL
HBTS-TR/PT1000/BSP/90	90 mm	HBTS-TR/PT1000/90-EL
HBTS-TR/PT1000/NPT/60	60 mm	HBTS-TR/PT1000/60-EL
HBTS-TR/PT1000/NPT/90	90 mm	HBTS-TR/PT1000/90-EL



# Cable Temperature Sensor (Without transmitter)

Category: HBTS-PT100/Cable - HBTS-PT1000/Cable



## Functional description:

The Cable Temperature Sensors are used as signal sensors for electronic thermostats, regulators and thermometers. The sensors can be used virtually anywhere where you want to measure or monitor temperature especially for applications in the industrial refrigeration industry.

The sensor can be mounted in a sensor well or directly

The HBTS-PT1000/cable is also included as a spare part for the HBDF-MK2 sensor.

## Technical data

Electrical specifications		Mechanical specifications	
Electrical Connection	2,0 Meter	Material – probe tip	AISI 316 L
Sensor element	PT100 / PT1000	Material – cable	Red/orange silicone
Sensor class/ Tolerance class	DIN B	Sensor element	Ø6 X 50 mm
Sensor design	4-wire (4 X 0,24mm <sup>2</sup> ) (PT 100) 2-wire (2 X 0,5 mm <sup>2</sup> ) (PT1000)		
Environmental conditions			
Temperature range	-40...+130°C (peak 150°C)		
Protection degree	IP68		

## Ordering codes

Sensor type	Sensor length	Dimension	Ordering code
PT 100	2 m	Ø6X50 mm	HBTS-PT100/Cable-2M
PT 100	5 m	Ø6X50 mm	HBTS-PT100/Cable-5M
PT 100	10 m	Ø6X50 mm	HBTS-PT100/Cable-10M
PT 1000	2 m	Ø6X50 mm	HBTS-PT1000/Cable-2M

# Wall Mounted Temperature Sensor with Transmitter

With 4-20mA output for temperature measurement in refrigeration systems

Category: HBTS-TR -W | HBTS-TR/CABLE



HBTS-TR-W



HBTS-TR/CABLE-2M

## Functional description:

HBTS-TR-W and HBTS-TR/Cable-2M are together with HBTS-TR a new family of temperature sensors with integrated transmitter. By use of our HB-TOOL (software) it is easy to configure the range in temperature where the 4-20 mA signal shall operate. The two versions are for wall mount with either direct measurement or with cable for hot spot measurement. All sensors with PT1000 high accuracy measurement.

## Mechanical dimensions

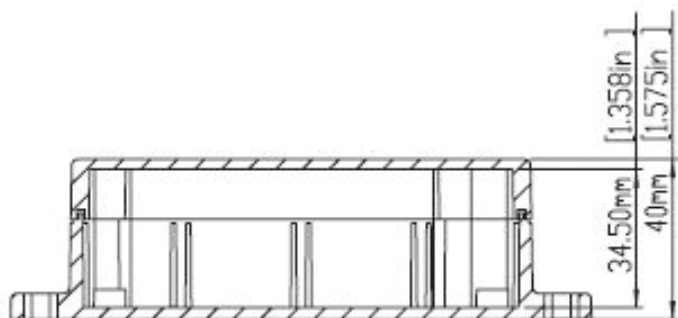
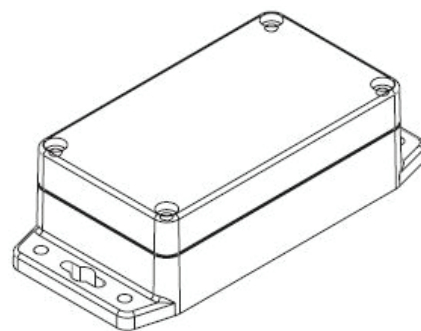
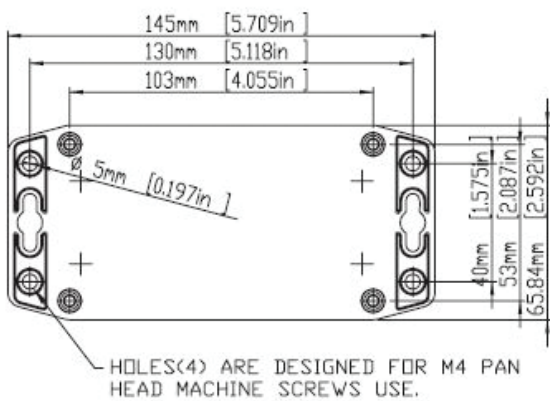

## Technical data

Power Supply		Mechanical Specifications	
Voltage	24 V AC/DC		
Current consumption*	Max 600 mA (with heater)	Material – mechanical parts	AISI 316L
Electrical connection	Screw terminals	Material – electronic parts	Nylon 6 (PA)
Sensor type	PT1000		
Analog output	4 - 20 mA		
Max. load	500 ohm	Sensor length/ sensor length chassis	145 mm / 115 mm
		Sensor thickness	40 mm
		Sensor width	65 mm
Cable entry:	PG7 / M12		
Approvals		Installation conditions	
EMC Emission	EN61000-3-2	Ambient temperature	-30...+50°C
EMC Immunity	EN61000-4-2	Temperature range	-40°C...+130°C (peak 150°C)
	CE ROHS COMPLIANT 2002/95/EC	Protection degree	IP65
Configuration		Vibrations	IEC 68-2-6 (4g)
Type of configuration	HB Tool		
Tool to be used	HB software		

\* Total consumption is sensor consumption plus output and it depends on ambient temperature.

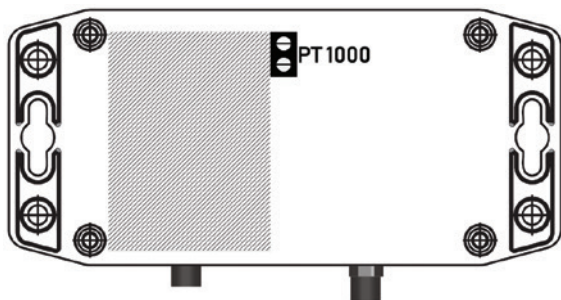

## Ordering codes

Designation	Sensor type	Dimension	Ordering code
Wall Mounted Temp. Sensor with Transmitter	PT1000	145 (115) x 65 x 40 mm	HBTS-TR-W
Temp. Sensor with Transmitter	PT1000	145 (115) x 65 x 40 mm	HBTS-TR/CABLE-2M

## Spare parts

Position	Designation	Specification	Dimension	Ordering code
1	Mechanical part Temp. Sensor	Pt1000-Cable type	2 m	HBTS-PT1000/Cable-2M
2	Communication cable	HB USB cable		HBxC-USB

# Pressure Sensor

Category: HBPS



## Functional Description:

HBPS is a pressure sensor that is specially developed for the refrigeration industry. The sensor has a stainless membrane, and the housing is also made of stainless steel. It has a quick reaction time of < 1 s, and it is accessible in multiple pressure ranges.

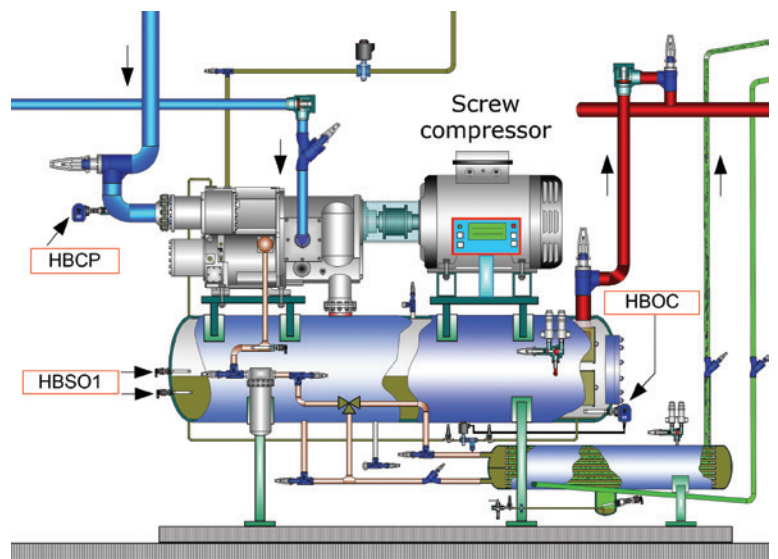

## Technical data

Power supply		Mechanical specifications	
Connector	M12 - DIN 0627	Thread connection	G 1/4" - Form E
Voltage	24 V AC/DC ±10%	Material – mechanical parts	AISI 304
Analog output	4...20 mA	Material – electronic parts	AISI 304
Pin surface treatment	Gold		
Connection	2-wire		
Environmental conditions		Approvals	
Ambient temperature	-40...+105°C	EMC	EN 61000-2
Refrigerant temperature	-40...+125°C	Accessories	
Max. operational pressure	-1...200 bar	Cable-5m	HBxC/M12-5
Protection degree	IP67		
Vibrations	IEC 68-2-6 (4g)		

## Mechanical dimensions

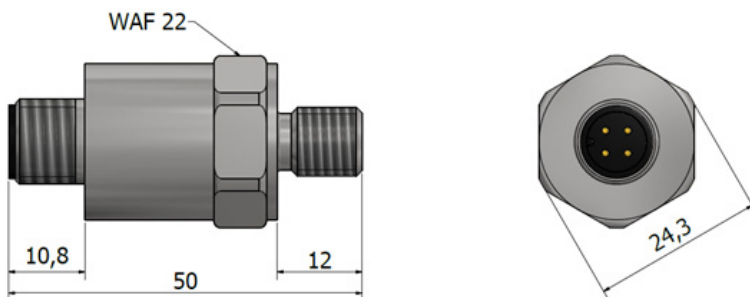

## Ordering codes

Pressure range	Thread type	Ordering code
-1...5 bar	1/4" G - Form E	HBPS-5-1/4-G/E
-1...5 bar	1/4" NPT	HBPS-5-1/4-NPT
0...6 bar	1/4" G - Form E	HBPS-6-1/4-G/E
0...6 bar	1/4" NPT	HBPS-6-1/4-NPT
-1...9 bar	1/4" G - Form E	HBPS-9-1/4-G/E
-1...9 bar	1/4" NPT	HBPS-9-1/4-NPT
-1...25 bar	1/4" G - Form E	HBPS-25-1/4-G/E
-1...25 bar	1/4" NPT	HBPS-25-1/4-NPT
-1...40 bar	1/4" G - Form E	HBPS-40-1/4-G/E
-1...40 bar	1/4" NPT	HBPS-40-1/4-NPT
-1...100 bar	1/4" G - Form E	HBPS-100-1/4-G/E
-1...100 bar	1/4" NPT	HBPS-100-1/4-NPT
-1...200 bar	1/4" G - Form E	HBPS-200-1/4-G/E
-1...200 bar	1/4" NPT	HBPS-200-1/4-NPT



# Valves

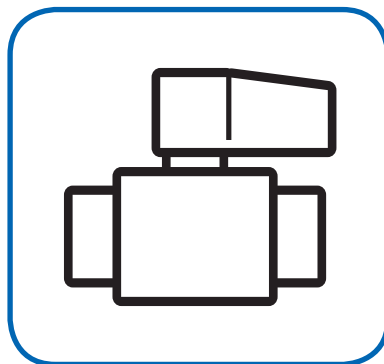

## Valves

**Function:** **Siemens Modulation Valve MVS661**  
**Applications:** Float regulation in refrigeration systems  
**Medium Temperature:** -40...+120°C  
**Supply:** AC 24 V, DC 20..30 V



Page 184

**Function:** **Siemens Modulating Valve M2FP03GX**  
**Applications:** Float regulation in refrigeration systems  
**Medium Temperature:** -40...+100°C  
**Supply:** AC 24 V



Page 187

**Function:** **Carel Stepper Motor Valve**  
**Applications:** Float regulation in refrigeration systems  
**Medium Temperature:** -40...+70°C (-40...+58°F)



Page 190

# Siemens Modulation Valve

## Category: MVS661

Capacity requirements: 0,16 - 6,30 Kvs [m<sup>3</sup>/h]



### Functional description:

MVS661 is a modulating valve for the connection to the refrigerant level control sensor type HBLC. It can be used for all refrigerants and has a fast reaction time. The modulating valve requires only supply and connection from the HBLC.

Hermetically sealed 2-port valves for modulating control of refrigerant circuits including chillers and heat pumps.

- Expansion gas, flash gas and suction throttle applications with one type of valve
- PN 63, stainless steel with welding connections
- Integrated power electronic with precise position feedback signal
- For ammonia R717 and all standard refrigerants, noncorrosive gases/liquids and CO<sub>2</sub> (R744). It is not suited for use with inflammable refrigerants.

### Product features

- One valve type for expansion, hot-gas and suction throttle applications
- Hermetically sealed
- Selectable standard interface DC 0/2...10 V or DC 0/4...20 mA
- High resolution and control accuracy
- Precise positioning control and position feedback signal
- Short positioning time (< 1 second)
- Closed when deenergized
- Robust and maintenance-free
- DN 25

The Siemens MVS661 Series is for capacity requirements of 0,16 – 6,30 Kvs [m<sup>3</sup>/h]

**We recommend Siemens valves for evaporators larger than 150 kw.**



## Technical data

Electrical specifications		Mechanical specifications	
Operating voltage	AC 24 V, DC 20...30 V		
Power consumption	22 VA	Material - valve body	Steel / CrNi steel
Positioning signal		Material - inside set	CrNi steel
Environmental conditions			
Ambient temperature, operation	-25...55° C		
Medium temperature	-40...120° C		
Ambient temperature, IP version	-45...55° C		
Mounting position	Upright to horizontal		
Permissible operating pressure	6300 kPa		
Valve characteristic	Linear		
Protection degree	IP65		



## Choose the valve ordering code and the sensor family based on capacity requirements – Kvs [m<sup>3</sup>/h]

Valve and sensor selection:

MVS 661 IP valve with built in heater „Siemens ASR61-IP

[3]

[2]

[1]

Sensor Family	Producer	Ordering code	Refrigerant	Actuator/Coil	Kvs [m <sup>3</sup> /h]	Size	MOPD
HBLC/C/S-xxx	Carel	E2B05CS000	NH3,HFC,CO2	Integrated	0.016	10 mm	140 bar
		E2B09CS000	NH3,HFC,CO2	Integrated	0.0275	10 mm	140 bar
		E2B11CS000	NH3,HFC,CO2	Integrated	0.0475	10 mm	140 bar
		E2B14CS000	NH3,HFC,CO2	Integrated	0.0725	10 mm	140 bar
		E2B18CS000	NH3,HFC,CO2	Integrated	0.106	10 mm	140 bar
		E2B24CS000	NH3,HFC,CO2	Integrated	0.21	10 mm	140 bar
		E2B35CS000	NH3,HFC,CO2	Integrated	0.34	10 mm	140 bar
HBLC/C-xxx	Siemens	MVS661.25-016N	NH3,HFC,CO2	Integrated	0.16	DN25	53 bar
		MVS661.25-0.4N	NH3,HFC,CO2	Integrated	0.40	DN25	53 bar
		MVS661.25-1.0N	NH3,HFC,CO2	Integrated	1.00	DN25	53 bar
		MVS661.25-2.5N	NH3,HFC,CO2	Integrated	2.50	DN25	53 bar
		MVS661.25-6.3N	NH3,HFC,CO2	Integrated	6.30	DN25	53 bar
HBLC/C-xxx	Danfoss/Siemens	ICS25	NH3,HFC,CO2	Siemens M2FP	6-12	DN25	18 bar
		ICS32	NH3,HFC,CO2	Siemens M2FP	9-17	DN32	18 bar
		ICS40	NH3,HFC,CO2	Siemens M2FP	15-26	DN40	18 bar
		ICS50	NH3,HFC,CO2	Siemens M2FP	23-40	DN50	18 bar
		ICS65	NH3,HFC,CO2	Siemens M2FP	23-70	DN65	18 bar
		ICS100	NH3,HFC,CO2	Siemens M2FP	142	DN100	18 bar
		ICS125	NH3,HFC,CO2	Siemens M2FP	207	DN125	18 bar
		ICS150	NH3,HFC,CO2	Siemens M2FP	354	DN150	18 bar

The Danfoss/Siemens combination consists of the ICSxx pilot valve from Danfoss and the Siemens M2FP actuator

## Ordering codes

Valve type	Kvs [m <sup>3</sup> /h]	QoE [kW]*	DN	Ordering code
MVS661.25-016N	0,16	60	25	Siemens MVS...0.16N
MVS661.25-0.4N	0,4	150	25	Siemens MVS...0.4N
MVS661.25-1.0N	1,0	375	25	Siemens MVS...1.0N
MVS661.25-2.5N	2,5	940	25	Siemens MVS...2.5N
MVS661.25-6.3N	6,3	2365	25	Siemens MVS...6.3N
MVS661.25-0.16N-IP	0,16	60	25	Siemens MVS 0.16N-IP
MVS661.25-0.4N-IP	0,4	150	25	Siemens MVS 0.4N-IP
MVS661.25-1.0N-IP	1,0	375	25	Siemens MVS 1.0N-IP
MVS661.25-2.5N-IP	2,5	940	25	Siemens MVS 2.5N-IP
MVS661.25-6.3N-IP	6,3	2365	25	Siemens MVS 6.3N-IP

\*Calculated value from the Siemens calculation program. Te=20.Tc=30. Superheat and subcooling 2K. Refrigerant R717.

## Mechanical dimensions

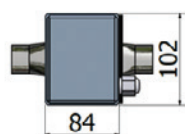
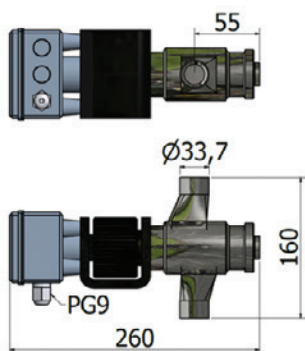

Siemens ASR61

Replacement electronic for MVS661 (Also available with heater)



Valve insert ASR..N

## Additional info

An exchangeable ASR..N valve insert allows for different kvs-values with the same type of DN25 valve. In the event of service, this insert can also be replaced on the plant.

## Spare parts

Valve type	Valve type	Kvs [m <sup>3</sup> /h]	DN	Ordering code
Siemens MVS 661	Replacement electronic for MVS661			Siemens ASR61
Siemens MVS 661	Replacement electronic for MVS661 with heater			Siemens ASR61-IP
Siemens MVS 661	Valve insert ASR..N:			
	ASR0.16N	0,16	25	Siemens ASR0.16N
	ASR0.4N	0,4	25	Siemens ASR0.4N
	ASR1.0N	1,0	25	Siemens ASR1.0N
	ASR2.5N	2,5	25	Siemens ASR2.5N
	ASR6.3N	6,3	25	Siemens ASR6.3N

We recommend using the "Siemens Modulating Valve Selection Program" for calculating valve size [kW], which can be downloaded for free under the "Downloads" tab on our website.

The calculation program for dimensioning of Siemens modulating valves is indicative and developed by Siemens. HB Products is not responsible for calculations and cannot be held liable for any damages or other liability arising from calculations from this Siemens Refrigeration Valve Selection Program.

# Siemens Modulating Valve

## Category: M2FP

Capacity requirements: 6 - 354 Kvs [ $m^3/h$ ]



### Functional description:

M2FP03GX is a modulating valve for the connection to the refrigerant level control sensor type HBLC. It can be used for all refrigerants and has a fast reaction time. The modulating valve requires only supply and connection from the HBLC.

- 2-port modulating pilot valve with magnetic actuator, PN32, AC 24 V, DC 0...10 V / 4...20 mA / 0...20 Phs to control main valves
- Hermetically sealed 2-port valve as a control valve for main valves from 2" to 5".
- PN32 with threaded connections
- For use with refrigerants such as R22, R134a, R404A, R407C, R507 and ammonia R717

The Siemens M2FP Series is for capacity requirements of 6 – 354 Kvs [ $m^3/h$ ]

**We recommend Siemens valves for evaporators larger than 150 kw.**

## Technical data

Electrical specifications		Mechanical specifications	
Operating voltage	AC 24 V		
Power consumption	13 VA	Material – valve body	Steel / CrNi steel
Positioning signal	DC 0...10 V; DC 4...20 mA; DC 0...20 V Phs	Material – inside set	CrNi steel
Environmental conditions			
Ambient temperature, operation	-40...50 C		
Medium temperature	-40...100 C		
Mounting position	Any		
Permissible operating pressure	3200 kPa		
Valve characteristic	Linear		
Protection degree	IP54		



## Choose the valve ordering code and the sensor family based on capacity requirements – Kvs [m<sup>3</sup>/h]

Valve and sensor selection:

MVS 661 IP valve with built in heater „Siemens ASR61-IP

[3]

[2]

[1]

Sensor Family	Producer	Ordering code	Refrigerant	Actuator/Coil	Kvs [m <sup>3</sup> /h]	Size	MOPD
HBLC/C/S-xxx	Carel	E2B05CS000	NH3,HFC,CO2	Integrated	0.016	10 mm	140 bar
		E2B09CS000	NH3,HFC,CO2	Integrated	0.0275	10 mm	140 bar
		E2B11CS000	NH3,HFC,CO2	Integrated	0.0475	10 mm	140 bar
		E2B14CS000	NH3,HFC,CO2	Integrated	0.0725	10 mm	140 bar
		E2B18CS000	NH3,HFC,CO2	Integrated	0.106	10 mm	140 bar
		E2B24CS000	NH3,HFC,CO2	Integrated	0.21	10 mm	140 bar
		E2B35CS000	NH3,HFC,CO2	Integrated	0.34	10 mm	140 bar
HBLC/C-xxx	Siemens	MVS661.25-016N	NH3,HFC,CO2	Integrated	0.16	DN25	53 bar
		MVS661.25-0.4N	NH3,HFC,CO2	Integrated	0.40	DN25	53 bar
		MVS661.25-1.0N	NH3,HFC,CO2	Integrated	1.00	DN25	53 bar
		MVS661.25-2.5N	NH3,HFC,CO2	Integrated	2.50	DN25	53 bar
		MVS661.25-6.3N	NH3,HFC,CO2	Integrated	6.30	DN25	53 bar
HBLC/C-xxx	Danfoss/Siemens	ICS25	NH3,HFC,CO2	Siemens M2FP	6-12	DN25	18 bar
		ICS32	NH3,HFC,CO2	Siemens M2FP	9-17	DN32	18 bar
		ICS40	NH3,HFC,CO2	Siemens M2FP	15-26	DN40	18 bar
		ICS50	NH3,HFC,CO2	Siemens M2FP	23-40	DN50	18 bar
		ICS65	NH3,HFC,CO2	Siemens M2FP	23-70	DN65	18 bar
		ICS100	NH3,HFC,CO2	Siemens M2FP	142	DN100	18 bar
		ICS125	NH3,HFC,CO2	Siemens M2FP	207	DN125	18 bar
		ICS150	NH3,HFC,CO2	Siemens M2FP	354	DN150	18 bar

The Danfoss/Siemens combination consists of the ICSxx pilot valve from Danfoss and the Siemens M2FP actuator

**Ordering codes**

Valve type	Kvs [m³/h]	QoE [kW]	DN	Ordering code
Siemens-M2FP03GX + Zm101/A	6 - 354		25	Siemens-M2FP/ZM101A

**Mechanical dimensions**

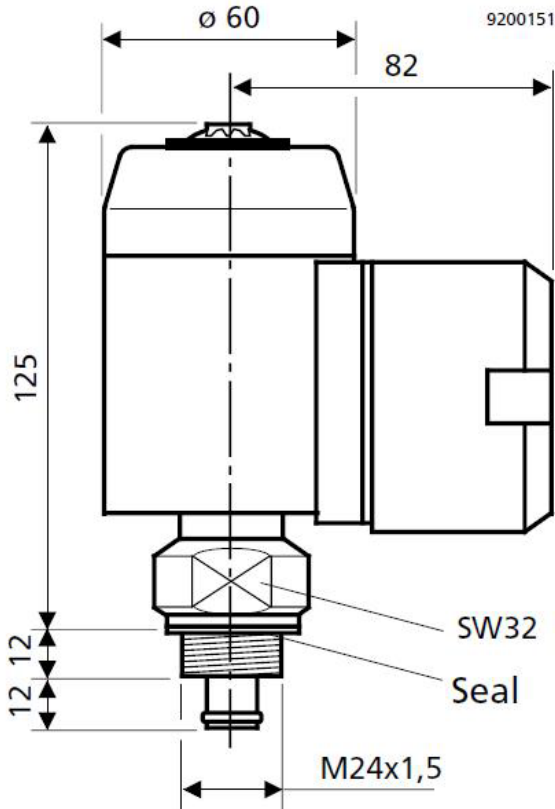

**Spare parts**

Valve type	Specification	Type	Ordering code
Siemens M2FP03GX	Mechanical part	Siemens M2FP03GX	Siemens M2FP03GX
Siemens M2FP03GX	Terminal housing for modulating pilot valve	Siemens ZM121/A	Siemens ZM121/A

\* We recommend using the “Siemens Modulating Valve Selection Program” for calculating valve size [kW], which can be downloaded for free under the “Downloads” tab on our website.

\*\*The calculation program for dimensioning of Siemens modulating valves is indicative and developed by Siemens. HB Products is not responsible for calculations and cannot be held liable for any damages or other liability arising from calculations from this Siemens Refrigeration Valve Selection Program.

# Carel Stepper Motor Valve

Category: Carel E2V



Carel "E2V05 BS 100" for NH3



Carel "E2V05 CS 000" for CO2

## Functional description:

Carel E2V stepper motor valve for the connection to the refrigerant level control sensor type HBLC, HBX and HBX-OVC. It can be used for all refrigerants and has a fast reaction time. We offer Carel stepper motor valves as Ø10 (Carel "E2V\*\* CS 000) for CO2 & HFC and Ø13 (Carel E2V\*\* BS 100) for NH3. The stepper motor valve requires only supply and connection from the "HB-xx/S" sensor and requires no additional stepper motor driver.



### Technical data

Electrical- & mechanical specifications		Environmental conditions	
OPhase current	450 mA	Max. operating pressure - MOP or MWP / MOPD	120/140 bar for CO2 & HFC / 45 barg / 35 barg for NH3
Drive frequency	50 Hz (up to 150 Hz for emergency closing)	Protection degree	IP 67
Phase resistivity (25°C / 77°F)	36 Ohm ± 10%	Refrigerant temperature	-40...+70°C (-40...+58°F)
Index of Protection	15°	Ambient temperature	-30...+70°C (-22...+58°C)
Linear advance/step	0,03 mm (0,0012 inches)		
Complete closing steps	500		
Control steps	480		
Connection	Ø10 for CO2 & HFC / Ø13 for NH3 (4 wire)		
Certifications:	CE, UL		

### Mechanical dimensions

Carel "E2V05 BS 100" for NH3

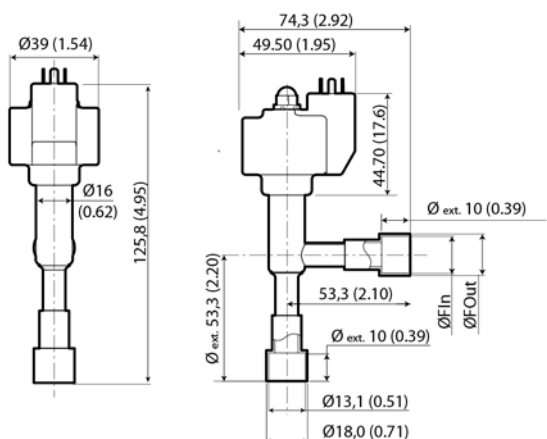

### Electrical installation

#### TIPO A / TYPE A

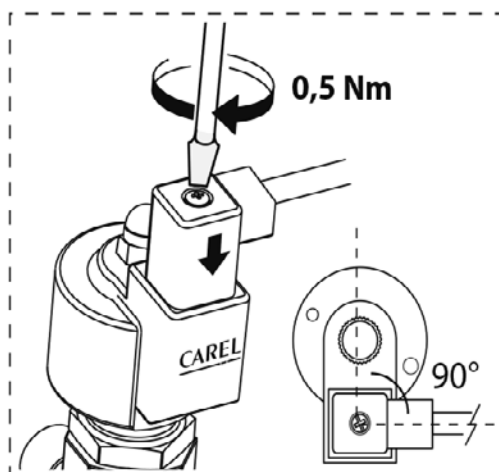
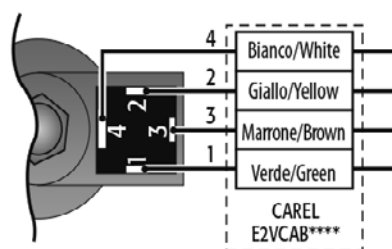

Carel "E2V05 CS 000" for CO2

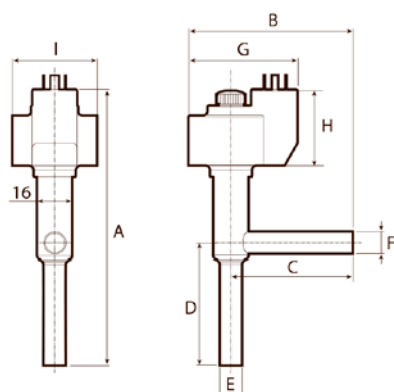

Valve type	A	B	C	D	E
E2V**CS000	15.9 mm	15.9 mm	54.8 mm	56 mm	ID 9/ OD 10 mm
	F	G	H	I	
	ID 9/ OD 10 mm	49.5 mm	44.7 mm	39 mm	

## Ordering codes

Refrigerant	Type	Dimensions	Cooling capacity	Ordering code
CO2/HFC	E2V05CS000	Ø10	0,014 [m <sup>3</sup> /h]	Carel E2V 05
CO2/HFC	E2V09CS000	Ø10	0,024 [m <sup>3</sup> /h]	Carel E2V 09
CO2/HFC	E2V11CS000	Ø10	0,042 [m <sup>3</sup> /h]	Carel E2V 11
CO2/HFC	E2V14CS000	Ø10	0,066 [m <sup>3</sup> /h]	Carel E2V 14
CO2/HFC	E2V18CS000	Ø10	0,09 [m <sup>3</sup> /h]	Carel E2V 18
CO2/HFC	E2V24CS000	Ø10	0,18 [m <sup>3</sup> /h]	Carel E2V 24
NH3	E2V05BS100	E2V05-B Ø13-13mm ODF	8,9 kW	Carel E2V 05 NH3
NH3	E2V09BS100	E2V09-B Ø13-13mm ODF	14,8 kW	Carel E2V 09 NH3
NH3	E2V11BS100	E2V11-B Ø13-13mm ODF	25,9 kW	Carel E2V 11 NH3
NH3	E2V14BS100	E2V14-B Ø13-13mm ODF	40,7 kW	Carel E2V 14 NH3
NH3	E2V18BS100	E2V18-B Ø13-13mm ODF	55,6 kW	Carel E2V 18 NH3
NH3	E2V24BS100	E2V24-B Ø13-13mm ODF	111 kW	Carel E2V 24NH3

(\*) Cooling capacity calculated in the following conditions: tevap: -12 °C (6.4 °F); tcond: 378 °C (I 00 °F); SC: I k (I .8 °R)



# Accessories



The programming cable HBxC-USB is used when installing HBLC, HBLC-R-IP, HBLT-Wire, HBLC-CO<sub>2</sub>, HBOC, HBCP, and HBX sensors. (Always included when ordering HBLT-Wire)

Ordering code
HBxC-USB



The M12 extension cable is used when you need more cable. For example if you need to hook up a HBX-DX sensor to a computer outside the freezer. The extension cable is a 5 cord. cable with M12 plug. It is available as a 5 or 10 meter extension. The extension cable is a 5 cord. PUR cable with M12plug (PUR 5x0.34 bk UL/CSA).

Specification	Ordering code
5 meter extension cable	HBxC-M12/5 extension
10 meter extension cable	HBxC-M12/10 extension



A conversion cable is used when replacing an HBLT-A1 sensor with a HBLT-wire. The M12 connection fits on the HBLT-wire sensor and the 4-pin male connector can be installed with the existing DIN connector.

Ordering code
HBxC-M12/DIN



The programming adapter/splitbox allows you to simultaneously supply the sensor while configuring it and running diagnostics. Option for ease of configuration when installing HBLC, HBLC-R-IP, HBLT-Wire, HBLC-CO<sub>2</sub>, HBOC, HBCP, and HBDX sensors.

Ordering code
HBxC-splitbox



HBSSR-Box contains an auxiliary relay.

Specification	Ordering code
Solid State Relay	HBSSR-BOX



A thread adapter is used when replacing an HBLT-A1 sensor with an HBLT-wire. The adapter has a 1" BSPP external thread and 3/4" NPT internal thread. Other adaptors for various threads are also available.

Specification	Ordering code
1" BSPP -> 3/4" NPT adapter with alu gasket	HBS/ADAP/8/2
1" BSPP -> 3/4" BSPP adapter with alu gasket	HBS/ADAP/8/6
1" NPT -> 3/4" NPT adapter	HBS/ADAP/9/2
1 1/8" UNEF -> 3/4" NPT adapter (TS)	HBS/ADAP/7/2
1 1/2" BSPP -> 3/4" BSPP adapter	HBS/ADAP/11/6
1 1/2" BSPP -> 1" BSPP adapter	HBS/ADAP/11/8
Bock 1" sight glass adapter	HBS/ADAP/1G/BOCK
Frascold M36 sight glass adapter	HBS/ADAP/M36/FRAS



The compressor adapter is used when installing an oil switch in the compressor housing where the oil sight glass is installed. The adapter is universal and is compatible with the most common compressor types. Suits oil switch with 1/2" NPT thread.

Specification	Ordering code
Universal flange adapter 3+4 hole for sightglass replacement, Thread: 1/2" NPT	HBS/ADAP/FLANGE/UNI



HB Products keeps various welding sleeves in stock for simple installation of HB Products switches and sensors. The stainless steel welding sockets are available in the following dimensions:

Thread	Dimensions	Ordering code
3/4" BSPP	26x32x2 mm	HBS/ADAP/WS/6
3/4" NPT	37mm	HBS/ADAP/WSS/2
3/4" BSPP	50mm	HBS/ADAP/WSS/6-50
3/4" BSPP	150mm	HBS/ADAP/WSS/6-150
1/2" BSPP	50 mm	HBS/ADAP/WSS/5
1/2" NPT	50 mm	HBS/ADAP/WSS/1
1" BSPP	33,5x41x2mm	HBS/ADAP/WSS/8
1" BSPP	43mm	HBS/ADAP/WSS/8-43
1" NPT	43mm	HBS/ADAP/WSS/9





The HBPSU Power Supply from HB Products is a 24 Voltage Power supply. The Power Supply is made in a solid 200mm x 150mm x 80 mm plastic casing and is available in two versions. The HBPSU24V/R is a 24V Power Supply with 2pc 24v 10A auxiliary relays can be used together with our switches HBSO1, HBSO2, HBSR-U and HBSC2-U to control a Siemens Modulating valve. The HBPSU 24 V is without an auxiliary relay.



**HBPSU 24V**  
24V Power Supply

**HBPSU 24V/R**  
24V Power Supply with 2pc, 24v 10A Relay

### Ordering code

Specification	Ordering code
24V Power Supply	HBPSU-24V
24V Power Supply with 2 pcs. 24V 10A Relay	HBPSU-24V-2-Relay



# Sensor Output

The output on a sensor from HB Products can be:

## Digital output (DO):

- 3-wire - Transistor high -PNP (Sourcing) or transistor low - NPN (Sinking)
- 3/4-wire - Solid-state relay

The transistor output is available with a NO or NC contact function. The solid-state relay has an NC or NO contact function or programmable NC/NO contact function.

## Analog output (AO):

- 3-wire analog output (AO) – 4...20 mA

## Digital output (DO) – 3/4-wire sensors:

The sensors have separate connections for power supply and load. Either the transistor or solid-state can act as the output. The transistor output needs a relay or a PLC digital input to operate. The solid-state relay is a standalone solution that can operate a valve directly.

As the solid-state operated switch is able to handle a valve directly, it is logical that the price will be higher. If the sensor with a transistor output should be able to handle a valve, a relay must be added in the price comparison.

## Specifications for the output:

Type	Sensors	Current load	Potential-free
Transistor output	HBSR-U, HBSO & HBSC2-U	50 mA	No
Solid-state output	HBSR-SSR-1/IP	1 A	Yes
Transistor output	HBLC	1 A	No
Solid-state output	HBLC/C (cable version)	1 A	Yes

Potential-free: A circuit that is separated from the control signal in order to have 100% EMC free signal. The benefit of a potential-free signal is that it is a standalone contact where both DC and AC power can be connected at a voltage range of 24...240 V.

## Transistor output:

The transistor output is available in PNP (Sourcing) or NPN (Sinking). The type that should be used depends on the type of PLC or relay used. PNP is traditionally found in Europe and NPN is traditionally used in USA and ASIA, however both types can be found worldwide.

PNP is an acronym of positive-negative-positive and NPN is an acronym of negative-positive-negative.

In general, Sinking (NPN) and Sourcing (PNP) are terms that define the control of direct current flow in a load. They are only pertinent with DC components and should not be associated with an AC control structure. Devices like relay output, reed switches, etc. are typically not affected since they are not dependent on current direction (unless they have devices sensitive to internal polarity, like LEDs or unidirectional spike suppressors).

**Potential-free:** A circuit that is separated from the control signal in order to have 100% EMC free signal. The benefit of a potential-free signal is that it is a standalone contact where both DC and AC power can be connected at a voltage range of 24...240 V.

**Transistor output:**

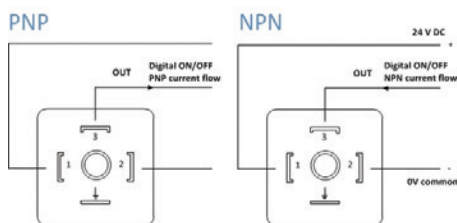

The transistor output is available in PNP (Sourcing) or NPN (Sinking). The type that should be used depends on the type of PLC or relay used. PNP is traditionally found in Europe and NPN is traditionally used in USA and ASIA, however both types can be found worldwide.

PNP is an acronym of positive-negative-positive and NPN is an acronym of negative-positive-negative.

In general, Sinking (NPN) and Sourcing (PNP) are terms that define the control of direct current flow in a load. They are only pertinent with DC components and should not be associated with an AC control structure. Devices like relay output, reed switches, etc. are typically not affected since they are not dependent on current direction (unless they have devices sensitive to internal polarity, like LEDs or unidirectional spike suppressors).

1. In short the differences between the types are: NP (Sourcing) are output that “source” or “push” current through the load. This means that the common connection to the load is the 0 VDC (-DC) line. Sourcing output modules require the load to be energized by a current that flows from +24 VDC (+DC), through the PNP Output switch device, through the load, and to the 0 VDC (-DC) line.

2. NPN (Sinking) is an output that “sink” or “pull” current through the load. In this case, the common connection to the load is the 24 VDC (+DC) line. Sinking output modules require the load to be energized by a current that flows from +24VDC (+DC), through the load, through the NPN Output switch device, and to the 0 VDC (-DC) line.

Please note that PLC manufacturers tend to mix the definitions, so it is recommendable to select the type of sensor based on the diagram and not the definition they are using.

**Solid-state relays (SSR):**

A solid-state relay is an ON-OFF control device in which the load current is conducted by one or more semiconductors - e.g. a power transistor, an SCR, or a TRIAC. The solid state can have either an NO or NC contact function. It is a programmable function that can be changed using the HB software tool.

**Contact function NO or NC:**

For the 3-wire sensors, the contact function can either be NO

(Normally Open) or NC (Normally Closed). This specifies the contact function’s position in a dry condition. Therefore, an NO contact function has a deactivated contact when the sensor is dry and an NC contact function has an activated contact when the sensor is dry. This is simple and logical for most people, but when using a HBSR-U switch for oil phase separation it gets a bit trickier. The HBSR-U detects ammonia and does not detect oil. By using it in an oil pot, it “detects” oil in the “dry” condition. So the required output must be selected based on the wet condition in order to have the same logic as for other switches.

The reaction time for the sensor is very close to 0 ms and the hysteresis is approx. 1 mm. Since high fluctuations may very often occur in both of the refrigerant and the oil, the PLC should be programmed with a time constant before the PLC reacts. We recommend the following time constant:

Liquid	Time response
Oil in crankcase compressors:	>1 s
Oil in filters	>5 s
Oil in tanks	>10 s
NH <sub>3</sub> in tanks	>20 s
HFC in tanks:	>20 s
CO <sub>2</sub> in tanks:	>30 s

**Analog output (AO):**

For industrial process control instruments, analog 4...20 mA current loop is commonly used. The 4 mA represents the lowest end of the range and 20 mA represents the highest. The key advantage of the current loop is that the accuracy of the signal is not affected by a voltage drop in the interconnecting wiring. Even if there is significant electrical resistance in the line, the current transmitter will maintain the proper current, up to its maximum voltage capability.

Depending on the source of current for the loop, devices may be classified as active (supplying power) or passive (relying on loop power). All sensors from HB Products with a 4...20 mA signal output are 3-wire sensors. The three wires are: +24 VDC, 0 VDC (common for both input and output), and output.

Sensors are factory calibrated with an output corresponding to the sensor probe length. Therefore, at the bottom of the sensor (0 mm) the output signal is 4 mA, and at the top of the sensor’s measurement range, it is 20 mA. E.g. for a probe of 800 mm length, the 4 mA is at 0 and the 20 mA is at 800 mm. If a smaller range of measurement is required, it is possible to calibrate the sensor to show 20 mA at 400 mm. This calibration functionality is available in both the sensor and the controllers provided by HB Products.

The 4...20 mA is typically not shown in any display, but the percentage corresponding to it is 4...20 mA: 0...100%.

**Control output as P-regulation:**

The 4...20 mA can be used to show the actual signal in a display, for example in %. The signal output from the sensor is linear

to the level in the tank and does not control any process. The 4...20mA signal can also be used for maintaining a constant level, such as a float regulator. In this case, the sensor output is connected to a controller that converts the signal to a valve open/close signal. The sensor signal is converted in the controller by a standard P-regulation process.

The P-regulation operates from a selected "Set-point" [%], where the set point is automatically maintained by signals from the sensor. If the refrigerant level is lower than the set point, the valve opens, and if the tank is empty, the valve opens fully. The closing function operates in the opposite way. A P-band defines the stiffness on the operation curve. A P-regulation normally operates within a P-band range of 30 to 60 %.

HB Products produces both sensors with built-in controllers and standalone controllers. We have defined these as decentralized controllers (sensor with built-in controller, e.g. HBLC) and centralized controllers (separate sensor and controller e.g. HBLT-C1 or a PLC). The decentralized solution is a cost-optimal solution and has fewer possibilities than the standalone controller. The standalone controller has separate alarm output for pumps etc.

In a P-regulator, only the P-band can be set. The choice of a suitable P-band is determined by two opposing requirements. In order to minimize the deviation of the regulation, a small P-band should be selected. This only requires a small change to the liquid level, so that the regulator changes the output signal to a suitable level. However, there is a limit to how much the P-band can be decreased. If the P-band is too small, a sudden change in liquid level can result in a wide opening of the liquid valve so that the liquid level rises above the desired level. Since there are always time delays in the system, it takes a certain time before the level sensor/probe detects this change, so that the liquid inflow can be reduced. Due to the time delay, the liquid level once again has time to drop below the desired level, before the level sensor/probe reacts and increases the liquid inflow again. The liquid level will therefore fluctuate around the desired value a few times before becoming stable.

If the P-band is reduced further, the liquid level will never

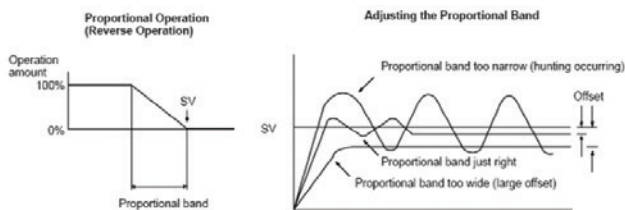

stabilize and we would have an unstable system. The P-band where the fluctuations begin is called the critical P-band. Instead, if the P-band is increased, you would have good stability but also a greater regulation deviation and a slower effect. Fig. 1. shows how the liquid level varies at different P-band settings for a certain change in load.

The P-band setting will thus be a compromise between stability and a small/large error in regulation.

In general, concerning control/regulation of liquid level in a refrigeration system, it is important that the regulation is steady/







slow since you do not want the compressor capacity regulation to be unnecessarily affected; rather optimal/steady operational conditions than a constant liquid level, normally with a change in liquid level of +/-5.

**Output signal is proportional to the input signal depending on the amplification (P-band):**

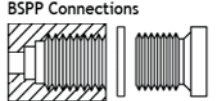
1. The P-regulator is load-dependent. It leads to a lasting deviation dependent on the load.
2. An increase in the P-band leads to better stability and a greater error in regulation.
3. A reduction of the P-band leads to worse stability and a smaller regulation error.
4. For the regulation of liquid level in a refrigeration system, we recommend only using P-regulation.

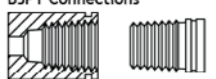
## Design recommendation – refrigerant switches:

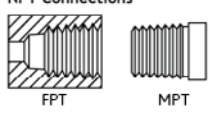
The refrigerant switches are normally mounted in a horizontal position. Depending on the type, the sensor can be delivered with different kinds of thread types.

We sell adaptors to convert between thread types:			
BSPP		British Standard Pipe Parallel. We <u>do</u> support this format. Straight shaped	<b>BSPP Connections</b> 
BSPT		British Standard Pipe Taper. Not included in our standard product range, please contact HB Products	<b>BSPT Connections</b> 
NPT		National Pipe Taper. We <u>do</u> support this format. Conical shaped.  MPT = Male Pipe Taper FPT = Female Pipe Taper	<b>NPT Connections</b> 
NPS		National Pipe Straight. We <u>don't</u> support this format.	
G1		Same as BSPP 1"	
1": 1"		= 1 Inch = 2,54cm	

Number	Thread type	Comments
2	3/4" NPT	National Pipe Taper
6	3/4" BSPP	British Standard Pipe Parallel (G)

The last number in the ordering code is normally the thread code. Below the thread type and the identical number in ordering code.

The switch can either be mounted in a sleeve welded to the tank or another mechanical part that can resist the design pressure in the system. Please note that welding may only be carried out when the electronic part is dismantled from the mechanical part and the power is switched off, in case the sensor is mounted during welding.

The sensors with NPT thread are delivered without any sealing element. The thread should be sealed with liquid sealant.

Below you can find refrigerant switches available both as 24 V AC/DC versions and 240 V AC versions:

Refrigerant	Ordering code	Refrigerant Dielectric	Refrigerant temperature	Max pressure
R717 (ammonia)	HBSR-U	17	-60°...+80°C	100 bar
R717 (ammonia)	HBSR-SSR-1/IP	17	-60°...+80°C	100 bar
R134a (HCFC)	HBSR-U	9.24	-60°...+80°C	100 bar
R22 (HFC)	HBSR-U	6.35	-60°...+80°C	100 bar
R410a (HFC)	HBSR-U	7.78	-60°...+80°C	100 bar
R507 (HFC)	HBSR-U	6.97	-60°...+80°C	100 bar
R744 (CO <sub>2</sub> )	HBSC2-U	1.5	-55°...+30°C	150 bar

The main electronics on all switches are identical. However when a spare part is ordered, the sensor must be set up (calibrated) for the refrigerant being used.

## Design recommendations – oil switches:

Number	Thread type	Comments	Comments
1	1/2" NPT	National Pipe Taper	Standard length
2	3/4" NPT	National Pipe Taper	Standard length
5	1/2" BSPP	British Standard Pipe Parallel (G)	Standard length
6	3/4" BSPP	British Standard Pipe Parallel (G)	Standard length
7	1 1/8" UNEF	Unified National Extra Fine	Short form type

The standard switches type HBSO are available in two types. The HBSO2 is calibrated for POE & PAG oil and the HBSO1 is calibrated for PAO & mineral oil:

- Mineral oil (M – Dielectric constant 2.2)
- Mineral oil with special treatment (hydrocracked oil) (M\*– dielectric constant 2.2)
- Polyalphaolefins (PAO– dielectric constant 2.2)
- Alcylbenzene (AB – dielectric constant 2.2)
- Polyolester (POE – dielectric constant 2.2)
- Polyalkylene Glycol (PAG – dielectric constant 3.5)

The type of oil used should depend on the recommendation of the compressor manufacturer. An overview of the different types of oils and what they are based on is available below:

Manufacturer	Type of oil	Based on
CPI	CP 1009-68	M*
	CP 1008-68	M*
	CP 412-100	PAG
	CP-4600-46F	PAO
	Solest 68	POE
	Solest 120	POE
	Solest 220	POE
	CP-1515-68	PAG
	CP-1515-100	PAG
	CP-1516-68	PAG
	CP-1516-100	PAG
	CP-4601-68	PAO
	CP-4601-100	PAO
	CP-9001-68	M
	CP-9001-100	M
	CP-1507-68	PAG
	CP-1507-100	PAG
	CP-4600-68F	PAO
	CP-4624-46F	PAO
	CP-4624-68F	PAO
Klüber Lubrication	Summit RHT 68	M*
	Summit NGSH-100	PAO-POE
Shell	S2 Fr-A68	M*
	Clavus SG 68	PAG
	Clavus 46	M
	Clavus 68	M
	Clavus G46	M
	Clavus G68	M
	S4 FR-V 46	AB
	S4 FR-V 68	AB
	Clavus R68	POE

Manufacturer	Type of oil	Based on
	Clavus R100	E
	S4 FR-F 68	E
	S4 FR-F 100	E
	S3 R68	M
	S4 PV 190	PAG
	Clavus SG68	PAG
Petro Canada	Reflo 68A	M*
TEXACO	Capella Premium	M*-PAO
Paramo	Mogul Komprimo ONC 68	M*
TOTAL	Lunaria NH 68	M*
	Lunaria NH 46	M
	Lunaria SH 46	PAO
	Lunaria FR 68	M
	Planetelf ACD 100FY	E
TOTAL	Planetelf ACD 150FY	E
	DACNIS LPG 150	PAG
Fuchs	Reniso Ultracool 68	M*-PAO
	Reniso PG 68	PAG
	Reniso S68	AB
	Reniso Synth 68	PAO
	Reniso KS 46	M
	Reniso KC 68	M
	Reniso Triton SE 55	E
	Reniso Triton SEZ 80	E
	Reniso Triton SEZ 100	E
	Reniso Triton SE 170	E
	Reniso PAG 220	PAG
	Reniso C 85 E	E*
	Reniso C 130 E	E*
	Reniso C 170 E	E*
NXT Lubricants	NXT-717	M*
Mobil	Zerice S32	AB
	Zerice S68	AB
	Gargoyle Artic SHC 226E	PAO
	Gargoyle Artic SHC NH68	AB-PAO
	Gargoyle Arctic 300	M
	Gargoyle Artic C Heavy	M



Manufacturer	Type of oil	Based on
	EAL Artic 68	E
	EAL Arctic 100	E
	Glygoyle 11	PAG
	Glygoyle 22	PAG
Castrol	Aircol 299	M
	Aircol AMX 68	M
	Aircol 2294	PAO
	Aircol SW68	E
	Aircol SW220	E
	PD 68	M

Oil system temperature: The standard oil switch design handles oil temperatures ranging from +0..+90 °C. A high temperature application is available for 0...+145°C. The limitation in temperature is based on the electronic components. A Cooling ribs are also added to the high temperature sensor.

# Oil in Refrigeration Systems

## The differences between oils and where the different types are most suitable

The following topics are important when it comes to selection of oil

- Requirements for oils
- Oil types
- Important characteristics and data relating to oils
- Which oil we should choose
- What damages the oil
- Oil analyses
- Examples of problems with oils

### Requirements for oils in refrigeration and heating pump systems

#### The oil must:

- Provide the necessary lubrication to bearings and sliding surfaces
- Provide the necessary sealing to the compression chambers for the rotating compressor (screw and scroll)
- Remove heat from bearings and stuffing boxes as well as compression heat
- Have adequate viscosity at current operational pressures and temperatures
- Have a miscibility/solubility ratio at the current temperature

#### Synthetic oils:

- Medium
- Reaction with and effect on other materials
- Environmental considerations (health, biodegradability, etc.)
- Price and availability

### Oil types for refrigeration and heat pump systems

#### Mineral oils (refined crude oils):

- Naphthenic and paraffinic
- Hydro-treated/cracked

#### Synthetic oils:

- Alkylbenzene (AB)
- Polyalphaolefins (PAO)
- Polyester (POE)
- Polyalkylene glycol (PAG)
- Polyvinyl ether (PVE)

#### Important data for the oil that is being assessed:

- Oil type
- Viscosity and viscosity index
- Miscibility/solubility curves with current refrigerant
- Flash point
- Pour point
- Initial acid number
- Aniline point etc.

#### Important data regarding the oil

- Viscosity class, ISO VG

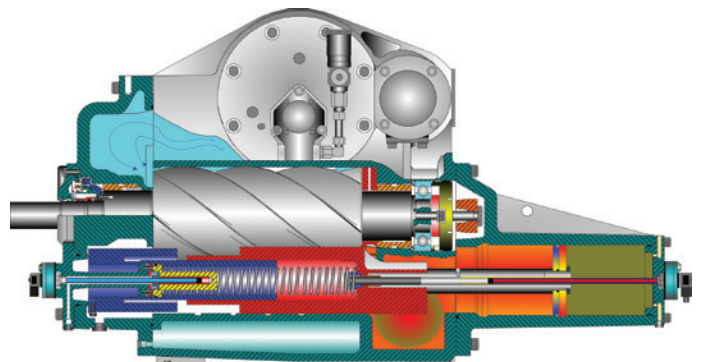

ISO VG No.	Viscosity area Kinematic cSt at +40°C
15	13.5 - 16.5
22	19.8 - 24.2
32	28.8 - 35.2
46	41.4 - 50.6
68	61.2 - 74.8
100	90.0 - 110.0
150	135.0 - 165.0
220	198.0 - 242.0
320	288.0 - 352.0
460	414.0 - 506.0

The compressors are generally designed for a viscosity of 8 cSt

## SOLUBILITY WITH AMMONIA ISO 68 REFRIGERATION OILS

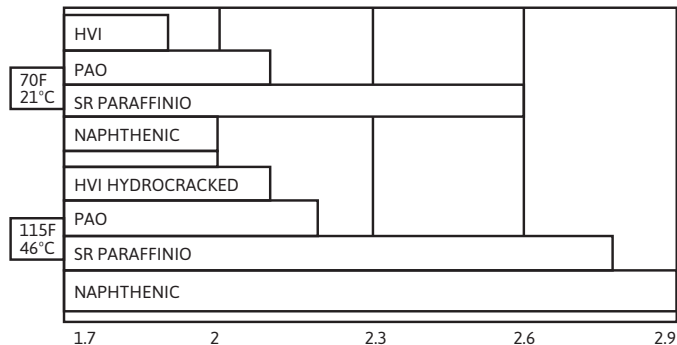

The miscibility of the oil with NH3 refrigerant.

## The oil's miscibility with the refrigerant

This is important for the oil return and the oil drain is either:

- Fully miscible
- Partially miscible
- Not miscible

Oil miscibility with the refrigerant depends on the oil type and the refrigerant, pressure, and temperatures.

### Miscibility with refrigerant, POE/R134a

## EMKARATE®RLE

Typical Physical Properties

Figure 1	DE
	212
Viscosity, cst	
40°C	14,0
100°C	3,4
Viscosity Index	118
TAN, mg KOH/gm	<0,1
Flash Point	
Open Cup, °C	222
Pure Point, °C	-58

## How Temperature Miscibility vs. Gencentratio

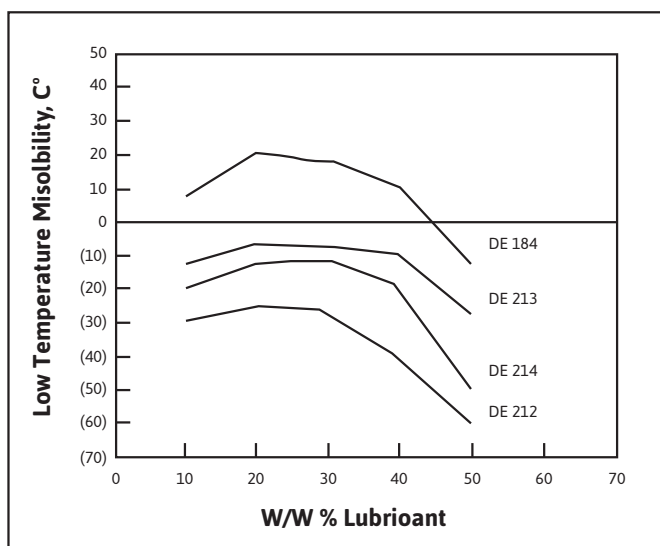

The curves only apply to the actual POE oil Emkarate RLE series. Other POE and other refrigerants generate a different curve.

## The oil's absorption / solubility of refrigerant

The absorption of the refrigerant changes the viscosity of the oil by:

- High temperature reduces absorption
- High pressure increases absorption

The ability of the oil to absorb the refrigerant depends on the oil type and the refrigerant. You need access to information on this so as to choose an oil that has adequate viscosity in the operational conditions of the system.

### The viscosity of the oil is different for reciprocating and screw compressors

For screw compressors the oil is added into the oil separator. Here, the pressure and temperature are relatively high. The oil's solubility with different refrigerants and actual viscosity at a given operational condition.  
CPUI Solest 120 (POE)

R-134a	9% DII, 16 cSt
R-22	19% DII, 6,7 cSt
HP-62	12% DII, 15 cSt
R-12	22% DII, 5 cSt

### Initially there are many options...

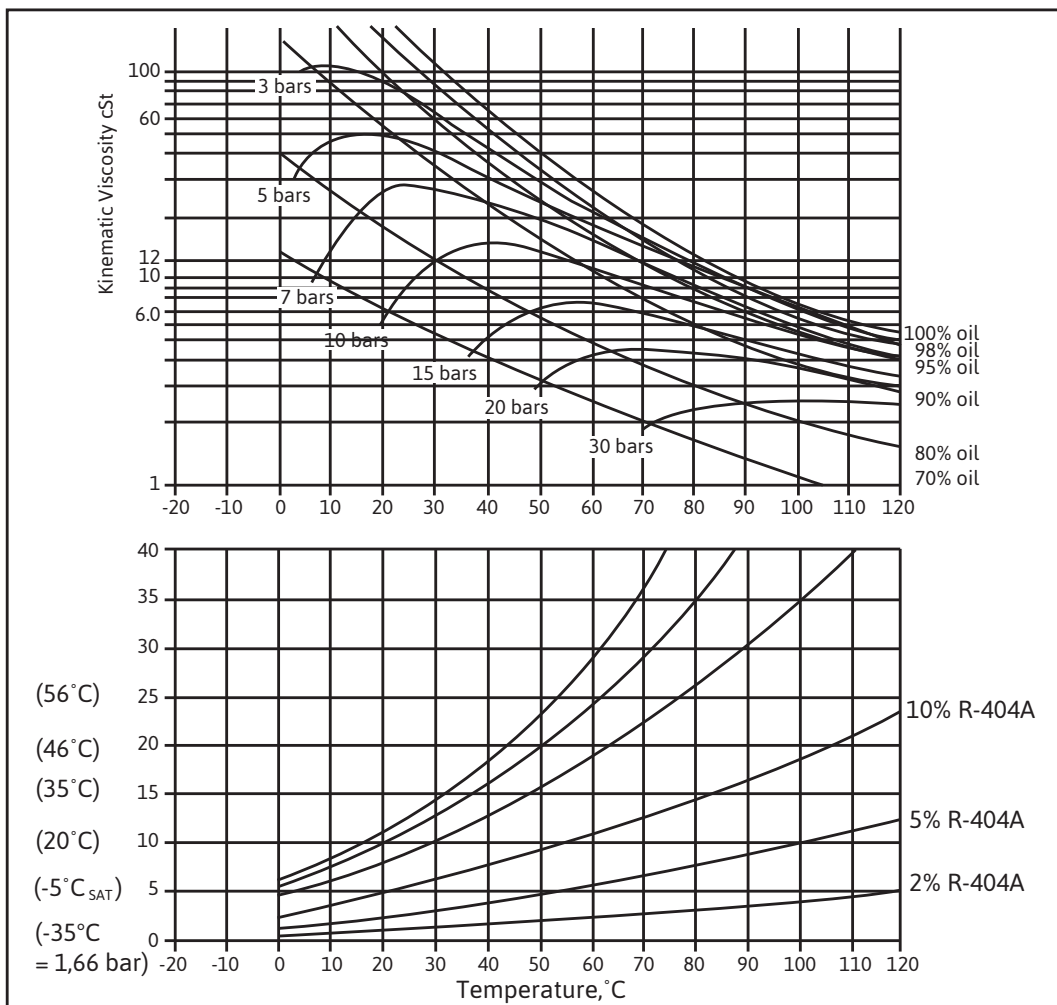

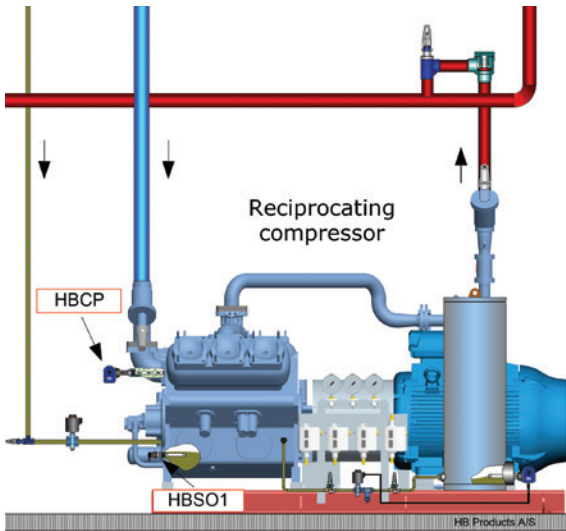

For reciprocating compressors the oil is added to the crankcase. The temperature and pressure are relatively low here.

**With a reciprocating compressor:**

- Pressure in the crankcase is 1.66 bar
  - Absorbed refrigerant 2%
  - Resulting viscosity 60 cSt
- For high viscosity. Choose an oil with a lower viscosity.

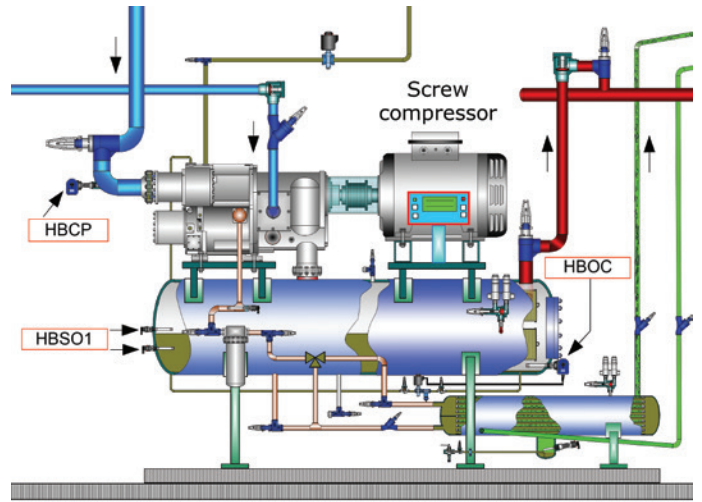

For screw compressors, oil is added to the oil separator. The pressure and temperature are relatively high here.

**With screw compressor:**

- Pressure in the oil separator, 15 bar
  - Absorbed refrigerant, 13%
  - Resulting viscosity, 6.8 cSt
- For low viscosity. Choose oils with a higher viscosity. Cooling to about 50 °C yields 12 cSt.

### Lubricating oil recommended by e.g. GEA screw compressors – refrigerant R717 (NH<sub>3</sub>)

Manufacturer	Type of oil	Basis	Viscosity at 40°C in cSt	Flash point in °C	Pour point in °C	Remarks	NSF Grade
CPI	CP 1009-68	M	68	226	-40	Hydrotreated for R717 only	H2
	CP1008-68	M	64.9	240	-39		H2
Klüber Lubrication	Klüber Summit RHT 68	M	68	240	-39		H2
Shell	Shell Clavus S 68	M	68	232	-39		
Petro Canada	Reflo 68A	M	58	236	-42		H2
TEXACO	Capella Premium	M/PAO	67	262	-42		
Paramo	Mogul Komprimo ONC 68	M	68	230	-33		
TOTAL	Lunaria NH68	M	68	230	-36		
Fuchs	Reniso Ultracool 68	M/PAO	62	250	-48		
NXT Next Lubricants	NXT-717	M	60.6	249	-56		

### Lubricating oil recommended by e.g. GEA screw compressors – refrigerant R744 (CO<sub>2</sub>)

Manufacturer	Type of oil	Basis	Viscosity at 40°C in cSt	Flash point in °C	Pour point in °C	Remarks	NSF Grade
CPI	CP-4600-68F	PAO	68			immiscible	H1
	CP-4624-46F	PAO	46				H1
	CP-4624-68F	PAO	68				H1
Fuchs	Reniso C 85E	E		278		Complete miscible	
	Reniso C 130 E	E	136		-27		
	Reniso C 170 E	E	170		-30	Attend to the miscibility	
Shell	Clavus SG 68	PAG	73.5	>250	-48	Partially miscible only	

#### Thorough assessments must be made

- Conditions associated with the actual compressor
- Operational conditions (pressure and temperature)
- Conditions in the refrigerant circulation
- Oil carry-over / oil return / oil drainage
- Effect on the heat exchanger
- Effect on stuffing and materials
- Air and water in the circulation

As a general rule, it is a combination or interaction between the mentioned factors that damage the oil and lead to a "chain reaction".

It is not just the situation in the compressor that plays a role

- The compressor manufacturer will have requirements for which oil or selection of oils must be used, and will determine this based on technical compressor-related considerations
- The technician must determine the technical conditions of the oil based on the entire system
- The final selection of oil must be carried out based on all the "players"
- Often, an oil will be chosen which leads to a low viscosity in practice. For periods, there may be operational conditions that lead to "wet suction". The oil thins out and the viscosity becomes too low.

## What damages the oil?

### The most important factors:

- Air (oxidation)
- Water
- High temperatures
- Different chemical reactions

As a general rule, it is a combination or interaction between the mentioned factors that damage the oil and lead to a "chain reaction".



A compressor has a "cold" and "hot" side...

## High water content

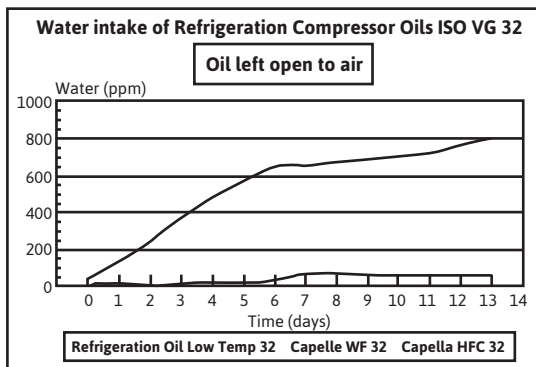

There must be no water in the refrigeration circuit! A water content that is too high will break down the oil, the refrigerant, and the materials in the refrigeration circuit.

## High temperatures

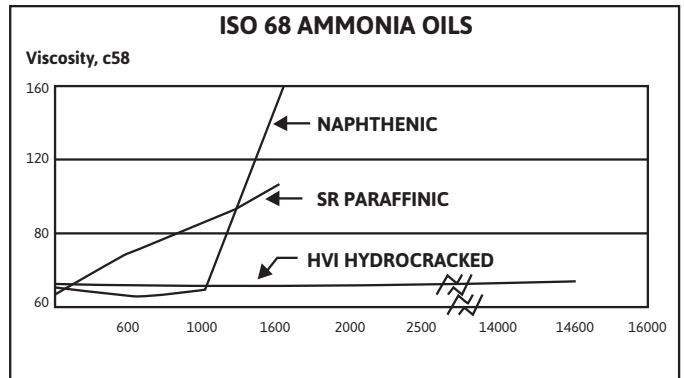

The temperature is important for the "chemistry" of the oil. Too high temperatures break down the oil and lead to vaporisation of the volatile elements. The viscosity and "pourpoint" will increase.

## Oil analysis

### The most important factors:

- Visual determination
- Acid number, mgKOH/g (TAN)
- Water content, ppm
- Viscosity, cSt
- Solid contaminants, mg/l
- IR analysis ("element analysis")

Please note: The location where the oil test is carried out in the system is of importance, and so is the method by which it is stored until the analysis is carried out in the lab.

## Requirement for analysis values

### The most important factors:

- Acid number, mgKOH/g (TAN) NOTE Basis initial acid number
- Increase <0.05: no measures
  - Increase 0.05-0.10: monitor
  - Increase >0.10: change oil etc.

### Water content, ppm

- New oil 20-50 ppm depending on the oil type
- Possible to achieve 20-50 ppm in a "good system"
- Increase 0.05-0.10: monitor
- 70-100 ppm: monitor
- 100-200 ppm: change oil and possibly filter dehydrator

### Viscosity, cSt

- Viscosity will either stay at the original value or increase, rarely decrease
- Increase up to 20% can generally be accepted
- A drop is normally due to an error in the analysis

### Solid contaminants, mg/l

Stamp: Normally with 25-50 mg/l Change oil and filter > 100-150 mg/l  
Screw: Normally with 10-30 mg/l  
Change oil and filter > 50-75 mg/l

### Result of oil analysis

Example of the oil analysis for a VP system converted from R12 to R134a

# Standards

Sensors and controllers by HB Products are developed and produced in accordance with current standards. Draft standards are also taken into account for new developments and during the reworking and modification of our existing products.

## The CE mark

CE marking indicates that a product has been assessed by the manufacturer and deemed to meet EU safety, health and environmental protection requirements. It is required for products manufactured anywhere in the world that are then marketed in the EU. The following guidelines apply to products produced by HB Products:

89/36/EEC: EMC Directive (EN 60 947-5-2)  
73/23/EEC: Low Voltage Directive

And for Ex products: 94/9/EC

Manufacturer's declaration: The HB Products A/S manufacturer's declaration are all available on our homepage and confirms that the company's products have been certified for conformity with the respective applicable guidelines.

## Ex certified sensors for Explosive Atmospheres

Ex certified sensors for Explosive Atmospheres. This includes sensors, switches and position transmitters from HB Products intended for use in Potentially Explosive Atmospheres according to Directive 2014/34/EU Product certificates:

DEMKO 05 ATEX 135657 (dated 2007-03-19)	
TÜV 16ATEX173252X issue 01 (dated 2017-01-19)	
IECEX_TUN_16.0001X issue 01 (dated 2017-01-26)	
TÜV 18ATEX226168X issue 00 (dated 2018-12-12)	Zone 1
IECEX_TUN_18.0027X issue 00 (dated 2019-01-10)	Ex ib Zone 1
TÜV 18ATEX226168X issue 01 (dated 2019-12-06)	Zone 0
IECEX TUN 18.0027X issue 01 (dated 2019-01-10)	Ex ia Zone 0

## The EMC standard

EMC simulations	Standard	Range
Conducted emission from the power art	IEC 60945	10 kHz-30 MHz
Electric field radiated emissions	IEC 60945	150 kHz – 2 GHz
RF electromagnetic fields	EN 61000-4-3	1 MHz – 2 GHz; 100 V/m
Conducted Interference RF	EN 61000-4-6	150 kHz – 80 MHz; 10 V
Conducted Interference AF	IEC 60533	50 Hz – 10 kHz; 3V/0,5V
ESD	EN 61000-4-2	+/- 8 kV Contact / Air discharge
Burst	EN 61000-4-4	+/- 2 kV DC powerpart / signal lines
Surge – lines/ground	EN61000-4-5	+/- 1 kV
Surge – lines/lines	EN61000-4-5	+/- 0,5 kV
High voltage	IEC 60092-504	550 V
Power supply, variations and interruptions	EN61000-4-11	Ub +50% / -25%



## The Environmental simulations

Environmental simulations	Standard	Range
Vibration	ISO 16750-3:2007	10 Hz – 2000 Hz / 4 g
Free fall	IEC16750	
Mechanical shock	DIN EN 60068-2-27:1995	100 g / 11 ms
Dry cold	DIN EN 60068-2-1:2006	-40°C (-40°F) / 24 h
Dry heat	DIN EN 60068-2-2:2008	+125°C (257°) / 96 h
Temperature cycling	DIN EN 60068-2-14:2000	
Damp heat	DIN EN 60068-2-78:2002	
Damp heat, steady state	DIN EN 60068-30:2006	
Protection	DIN 40050	IP68
Pressure resistant	Directive 97/23/EC (PED)	100/150 bar (depending on product)
HELIUM leak test	EN 473:2008	

# HB Online Webshop

For HB Products the webshop means less time spend for order handling and for that we will reward the customers who are using the webshop. The webshop also means that risk of order failures are reduced as customers are able to pick articles in menus, and the orders are placed directly in our order handling system in HB Products named "C5".

When we receive order from the webshop we will manually evaluate the order lead time, release the order and customers will as always receive an order confirmation.

- By ordering through our webshop you can:
- Avoid order handling fee of 30 EUR for orders <500 EUR by using our webshop
- Book and pay online with credit card
- Check current orders
- Check order history
- Register favorite products
- Obtain information about status in our stock about a given product
- Track order status in the webshop.

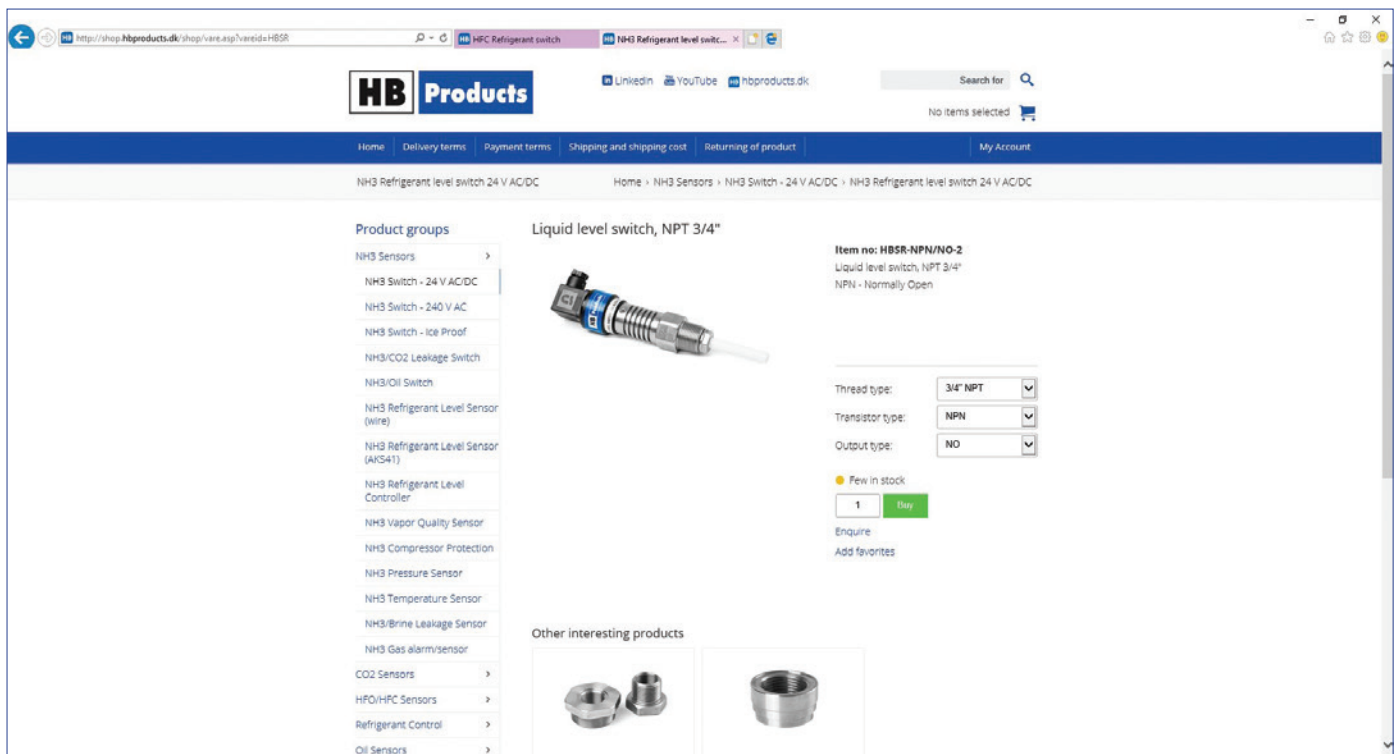

Do not wait to get all the benefits and saved costs by using our web-shop.

You can require your username and password for the HB online web-shop by contacting [info@hbproducts.dk](mailto:info@hbproducts.dk)

## Download the Sensor Configuration Tool

at [www.hbproducts.dk](http://www.hbproducts.dk)

Software  
HB Tool

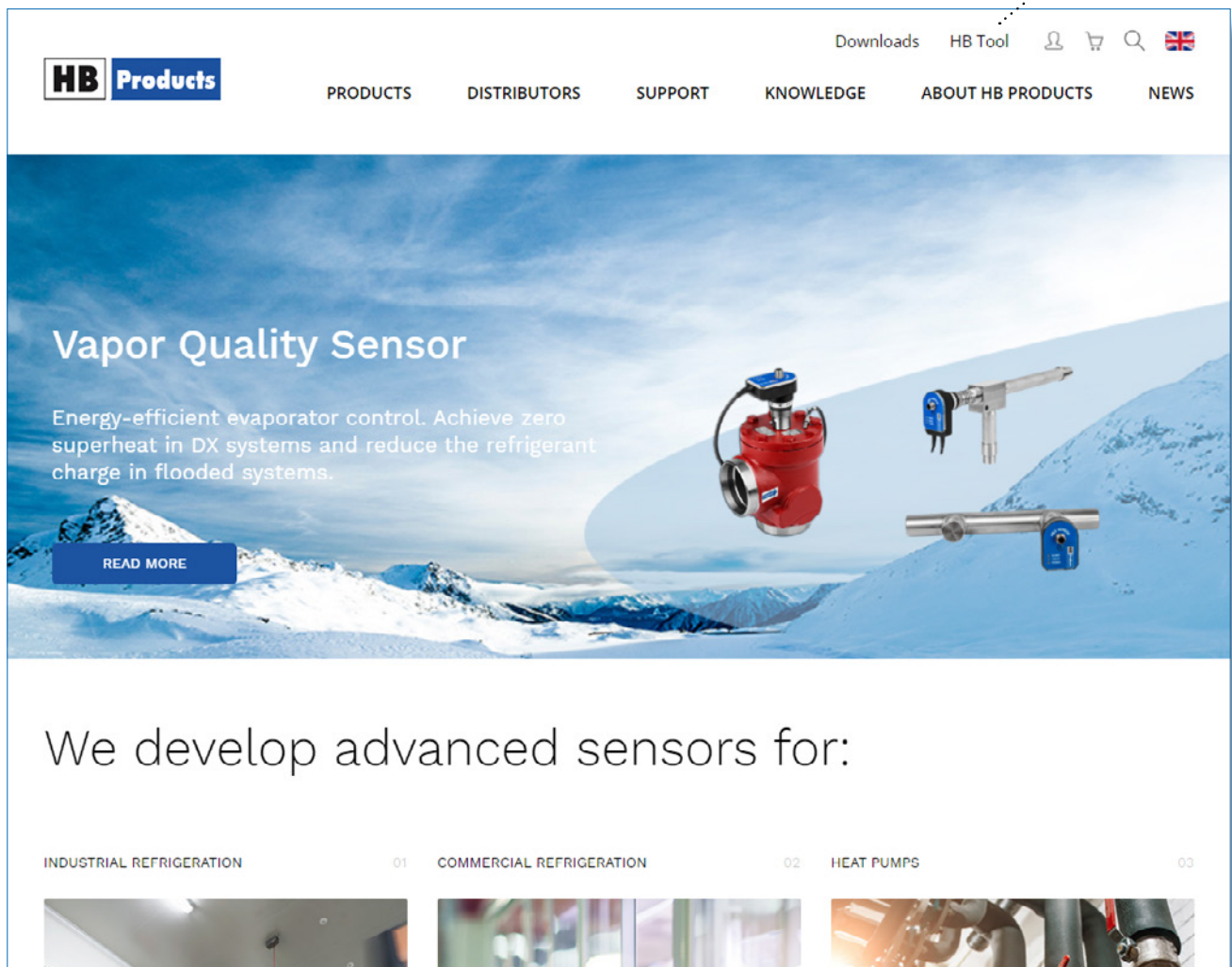

For further information please contact one of our local distributors,  
or HB Products A/S in Denmark  
Tel +45 8747 6200  
info@hbproducts.dk  
We will be happy to support you!

Visit our website [www.hbproducts.dk](http://www.hbproducts.dk)



[www.hbproducts.dk](http://www.hbproducts.dk)