

Data sheet

Danfoss gas detection Controller unit



The gas detection Controller Unit is used for a centralized monitoring and warning of hazardous gas concentrations. The input signals for the controller are collected from the local gas detection units of the types Basic, Premium and Heavy Duty via RS485 Fieldbus or Analog communication. In total 96 gas detection sensors can be handled via Fieldbus + 4 via Analog directly on the controller (+28 additional possible if expansion modules added).

The Controller Unit comes with 4 alarm relays available for external looped alarm devices. Additional relays and sensor wiring loops is possible by adding Expansion modules to the controller.

Each local gas detection unit is assigned a unique address in the Controller and by continuous communication with the individual GDU's the Controller reacts on alarm signals from the local GDU. The parameter setting and the actual state of each local GDU can be read in the Controller display.

Features

- For connection of up to 96 sensors via fieldbus + 32 via Analog (when 7 expansion modules added)
- Easy configuration via intuitive user-interface; helps simplify operator handling and minimize risk of operational setting errors
- Simple commissioning by standard parameter configuration
- Flexible connection to local gas detection units by either Analog or RS485 fieldbus communications
- Fieldbus wiring: Wire length up to 900 meters (2953 ft.) per segment.
- 4 relays for external alarm device circuits
- Up to 7 Expansion modules possible; allows additional 7 segments with a total of 7200 meters (23622 ft.) wiring and a total of 32 relays for alarm device circuits.
- Automatic self-diagnostics to ensure correct communication and operation
- Relay for communication error
- 6 menu languages
- Password protected settings allowing authorized access only
- Service alerts on display
- Conformity to EN 50545-1
- Enables regulatory compliance with EN 378:2016, ISO 5149:2014,

Contents	Page
Features.....	1
Specifications	3
Electrical connection	4
Fieldbus loop.....	5
Ordering	6

Specifications

Electrical	
Power supply	24 V DC \pm 20 %
Power consumption (24 V DC)	4 W, 150 mA
Analog input (4)	4 to 20 mA, overload and short-circuit- protected, input resistance 200 Ω
Tension for external analog transmitter	24 V DC (same as power supply), max. 100 mA / per sensor
Analog output (2) configurable for each input	Proportional, overload and short-circuit- protected, charge \leq 500 Ω 4 - 20 mA = measuring range 3.0 < 4 mA = underrange >20 - 21.2 mA = overrange 2.0 mA = fault
Alarm relay (4)	250 V AC, 5 A, potential-free, change-over (SPDT)
Fault relay (1)	250 V AC, 5 A, potential-free, normally open contact (SPST)
Visualization	
LCD	Two lines, 16 characters each, illuminated
Status LED (4)	Operation - fault - 1st alarm - \geq 2 nd alarm
Operation	6 push-buttons
Menu language (selectable)	German, English, Dutch, USA, French, Swedish
Interface fieldbus	
Transceiver	RS 485 / 19200 Baud
Gases	
Digital and analog sensors for toxic, combustible & refrigerant gases	
Environmental	
Humidity	15 - 95 % RH non-condensing
Working temperature	-5 $^{\circ}$ C to +40 $^{\circ}$ C (23 $^{\circ}$ F to 104 $^{\circ}$ F)
Storage temperature	0 $^{\circ}$ C to +40 $^{\circ}$ C (32 $^{\circ}$ F to 104 $^{\circ}$ F)
Physical	
Enclosure	Plastic housing ABS
Colour	RAL 7035
Protection class	IP 40
Weight	0.3 kg (0.8 lb.)
Packaging volumes	Ca. 4.4 l
Mounting	Top DIN rail mounting, installation in distribution box
Dimensions (Controller unit)	(W x H x D) 106 x 110 x 62 mm (4.2 x 4.3 x 2.4 in.)
Dimensions (Controller Solution)	(W x H x D) 298 x 420 x 140 mm (11.7 x 16.5 x 5.5 in.)
Wire connection:	
Power supply	Screw type terminal: 2.5 mm ² (14 AWG)
Output	2 x spring type terminal: min. 0.5 mm ² , max. 1.5 mm ² (22 to 16 AWG)
Input	Spring type: min. 0.5 mm ² , max. 1.5 mm ² (22 to 16 AWG)
Guidelines	
EMC - Directive 2014/30/EU	
Low voltage directive 2014/35/EU	
CE	
EN 50545-1, EN 50271	
Interface ModBus RTU RS 485	
Function	Transmission of current and average values, alarm and relay status, and analog output states in MODBus RTU RS 485 protocol to external devices

Electrical connection

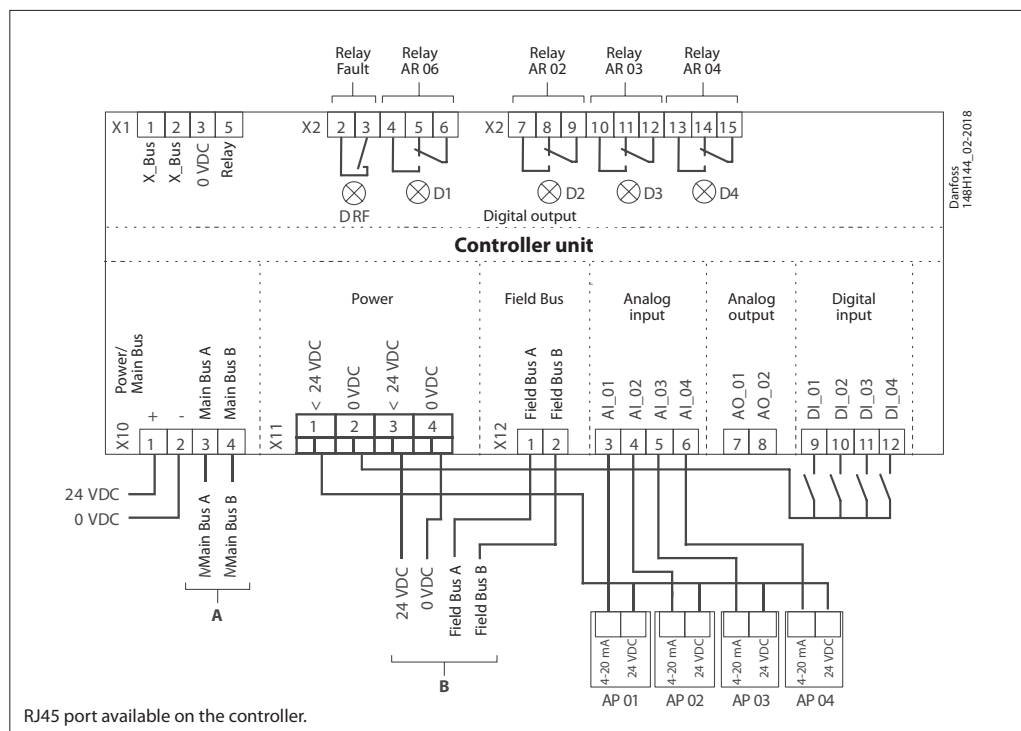

Fieldbus loop

Each GD controller can handle up to 96 sensors and handle any mix of individual Gas detection units of the types Basic, Premium and Heavy Duty.

The controller and the last GDU in each segment must be provided with a resistor of 560 Ohm. A U_{min} of 16 V DC must be secured at any spot in the loop.

The max. recommended loop wire length is 900 meter (2953 ft) per segment.

Below figure shows how to make proper connections between the controller and each GDU.

With additional segments (and additional controller expansion modules) the max recommended loop wire length is 7200 meter (23622 ft).

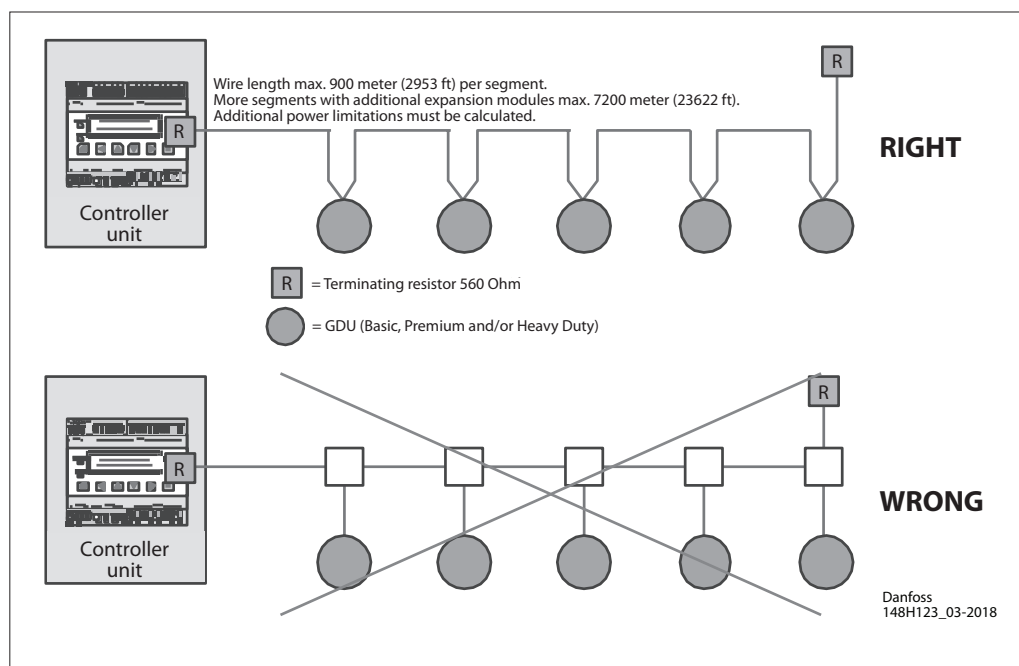
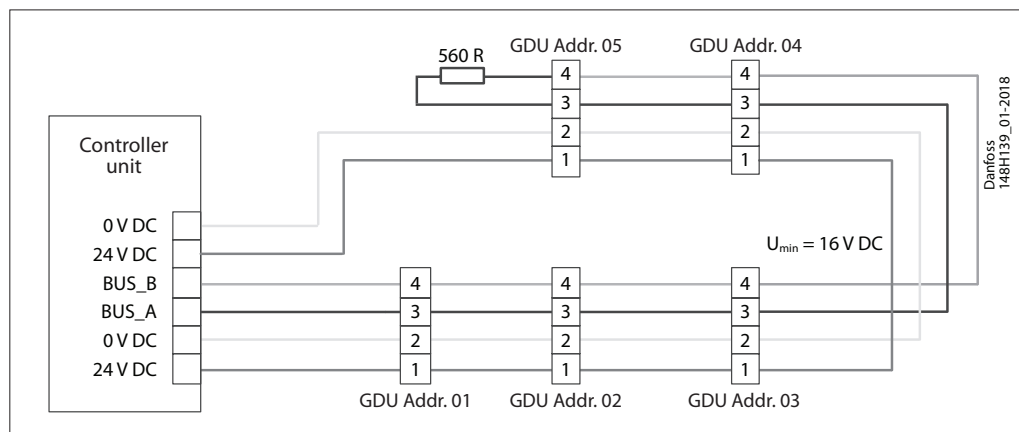

Ordering

Description	Code number
Controller unit	148H6231
Controller solution (controller + enclosure)	148H6221
Controller solution Uptime	148H6237
Warning module (wire break monitoring module)	148H6223
Controller expansion module	148H6222
Gateway for controller	148H6228

Controller solution

Controller unit placed in an enclosure ready to be connected to a power source. A separate UPS for the controller is available.

Gateway for controller

The gateway is an addition to the controller and used for communicating via Modbus TCP/IP.

Warning module (wire break monitoring module)

The warning module is used for monitoring the circuiting to the warning/alarm devices on a centrally controlled gas detection system. Wire breaks or wire interruptions in the alarm device loop will be reported to the central control.

Controller expansion module

The gas detection Controller Expansion module is used for expansion of the cable coverage in terms of number of loops and the total wire length. Each Controller Unit can handle up to 7 Expansion modules allowing additional 7 segments with a total of 7200 meters (23622 ft.) wiring and a total of 32 relays for alarm device circuits.

ENGINEERING
TOMORROW



Danfoss can accept no responsibility for possible errors in catalogues, brochures and other printed material. Danfoss reserves the right to alter its products without notice. This also applies to products already on order provided that such alterations can be made without subsequential changes being necessary in specifications already agreed. All trademarks in this material are property of the respective companies. Danfoss and the Danfoss logotype are trademarks of Danfoss A/S. All rights reserved.