

# GAS POWERED SUCTION STOP VALVE

## Type CK-5-DN

Port Size 32mm to 100mm (1¼" - 4")  
FOR AMMONIA, R22, R502, R134a, R404a  
AND OTHER COMMON REFRIGERANTS

### FEATURES

- Normally Open
- Low Pressure Drop
- Manual Opening Stem
- Integrated Pilot Solenoid on 32mm to 100mm (1-1/4" to 4") Sizes
- Use in Vertical or Horizontal Line
- Can be Installed on Side
- Design (PS): 28 bar (406 psig)
- Complies with Pressure Equipment Directive 97/23/EC

### DESCRIPTION

These piston-type, discharge gas powered, normally open, heavy duty, semi-steel bodied valves are built with control precision. The 32mm through 100mm (1-1/4" through 4", Fig. 1) port size valves are equipped with an attached modular pilot solenoid, A2D pilot regulator, and manual lift stem. The 32mm (1-1/4") port size has a PTFE main seat; the 40mm (1-5/8") port and larger have a metal to metal seat.

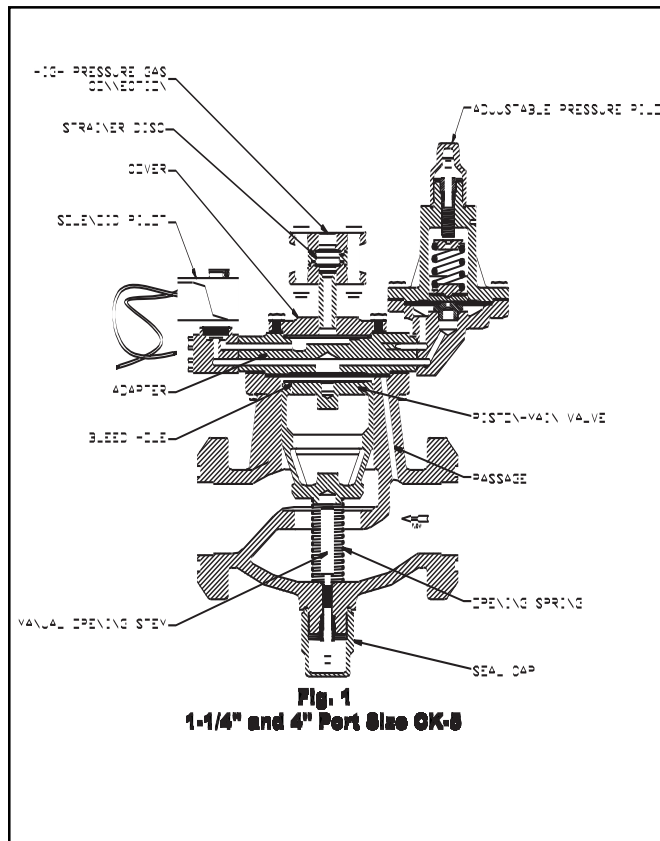

## BULLETIN DN50-23B

### Type CK5-DN



January 2007

### Installation and Service Information

### PURPOSE

The purpose of the CK-5 gas-powered suction stop valve is to provide the normal operating features of the R/S CK-2 stop valve. In addition, this unique control valve incorporates a built-in mechanical fail-safe feature which prevents the undesirable effects of an immediate opening of the valve in the event of an electrical power failure while the evaporator is in defrost.

Along with the standard R/S type CK-2 gas-powered suction stop valve, the CK-5 is typically used for low temperature applications in wet return lines in liquid recirculation systems or on both liquid legs and gas return legs of flooded evaporators. Due to its normally open construction, pressure drop is minimal in suction or wet return applications. In addition, on flooded evaporators normal gravity circulation is unrestricted. For gravity flooded evaporators, both valves should be installed with their flow arrows pointing towards the surge drum.

### PRINCIPLES OF OPERATION

For closing of the CK-5 valve, high pressure gas from an external source is admitted through the pilot solenoid valve to the top of the piston. The gas pressure acting on the piston forces it down, compressing the opening spring, firmly seating the valve's seat bead. The valve will not close unless pressure above the piston exceeds the downstream pressure by at least 5 psi (0.35 bar).

After the termination of the hot gas injection period, any style of suction stop valve must reopen in order for refrigeration to resume. For the CK-5 to open, the valve's pilot solenoid de-energizes, thereby interrupting the pilot stream flow of discharge gas to the top of the valves piston. The main valve will continue to remain closed, however, since residual pressure in the coil is transmitted through passage N, through the pilot regulator to the top of the piston. **[Note: The pilot regulator should be adjusted to maintain a minimal set point, approximately 10 psi.]** Under a standard defrost sequence for most low temperature evaporators, a "bleed down" or vent solenoid will energize to slowly equalize pressures between the coil and the suction line. It is imperative to incorporate a

“bleed down” solenoid in a defrost group of control valves which includes a CK-5 (See Fig. 5 and 6). Without this gradual equalization period, which generally takes one to two minutes, the CK-5 will stay closed for a prolonged period of time as the coil pressure slowly equalizes in series through the pilot regulator, then through the piston bleed hole.

The ability of the CK-5 to stay closed during an interruption of power, while an evaporator is in the process of defrosting, is its single greatest advantage. Where power failures can occur with any frequency, consideration should be given to this unique valve. By design, a standard CK-2, or a competitive valve with a similar design, would open immediately as residual coil pressure surges through the valve should power to the pilot solenoid suddenly be interrupted during a defrost. The design of the CK-5 prevents this from occurring and prevents the dangerous consequences to the system under these conditions.

In the event the CK-5 pilot solenoid de-energizes due to a power failure while the evaporator is in defrost, the defrost coil pressure (typically at or about 70 psig for ammonia) will continue to be transmitted through passage “N”, through the pilot regulator and to the top of the piston. This pilot pressure acts as a “closing” force acting upon the larger effective area of the top of the piston, and will overcome the “opening” force of coil pressure working against the underside of the piston. The valve will therefore remain closed due to the greater closing force until the coil pressure is equalized through the piston bleed hole.

The larger the evaporator, and the greater its internal volume, the longer this venting or equalization period will require. By utilizing a bleed down solenoid in the control group during the standard defrost sequence, the CK-5 will return to its open position immediately after the equalizing period which is controlled by the time clock.

## ADJUSTMENT

The pilot regulator should be adjusted to maintain a minimum set point of about 10 psi. This represents approximately 1/2 turn clockwise of the adjusting stem starting with the stem turned completely out.

## MANUAL LIFT STEM

If it is desired to hold open the CK-5 manually, remove #34 Sealing Cap and turn #27 Seat Lifting Stem inward as far as possible. The valve cannot close now until the #27 Seat Lift Stem is once again turned out.

STANDARD COIL *	
120 V 60 HZ OR 110 V 50 HZ	204843
240 V 60 HZ OR 220 V 50 HZ	204844
208 V 60 HZ	204845
240 V 50 HZ	204846
QUICK DISCONNECT COIL *	
120 V 60 HZ OR 110 V 50 HZ	204859
204 V 60 HZ OR 220 V 50 HZ	204860
208 V 60 HZ	204861
240 V 50 HZ	204862

\* Used on 1-1/4" (32mm) to 4" (100mm) Port Size Valves

## INSTALLATION

Protect inside of valve from dirt and chips during installation. The CK-5 Suction Stop Valve may be installed on its side or vertically upright in either vertical or horizontal pipe lines. Figure 5 illustrates the installation of the 32mm through 100mm (1-1/4" through 4") port size valves in a horizontal pipe line. Figure 6 illustrates the installation of the 125mm and 150mm (5" and 6") port size CK-5 stop valves in a horizontal pipe line. A bypass equalizing solenoid valve, a requirement with any size CK-5, is also shown. The remote discharge gas supply solenoid used with the larger 5" and 6" valves, the R/S type S8F, is a gravity closing valve and must be mounted in a horizontal line with its manual opening stem in a vertical position as shown.

Never install the valve with its pilot section directly beneath the main valve. The direct mounted pilot solenoid on the 32mm through 100mm (1-1/4" through 4") port size valves should be maintained above the centerline on a horizontal pipe.

When used on a suction or wet return line, the arrow on the valve should point in the direction of normal fluid flow. When used on either gas or liquid legs of a flooded evaporator, the arrow on the valve body should point from the evaporator to the surge drum.

## ELECTRICAL

The pilot solenoid used on the 32mm through 100mm (1-1/4" through 4") port size CK-5 stop valves, type S6B, is unique to the Refrigerating Specialties line of control valves. In addition, the pilot light assembly used with the S6B, the R/S type PLT-5, is unique to the product line. Like the R/S type PLT-2, the PLT-5 is designed to meet NEMA 4 (watertight) requirement for outdoor use. However, unlike other pilot lights available from R/S (types PLT-1 and PLT-2), **the PLT-5 is wired directly to line voltage.** Please refer to R/S product bulletin 60-30 for additional information regarding the PLT-5 pilot light assembly.

The Refrigerating Specialties Division’s molded, water resistant, Class “H” solenoid coil is designed for long life and powerful opening force. The standard coil housing meets NEMA 3R and 4 requirements. This sealed construction can withstand direct contact with moisture and ice. By definition, Class “H” coil construction will permit coil temperatures, as measured by resistance method, as high as 180°C. (356°F.) Final coil temperatures are a function of both liquid and ambient temperatures. The higher fluid temperatures require lower ambient temperatures so the maximum coil temperature is not exceeded. Conversely, low fluid temperatures permit higher ambient temperatures.

A solenoid coil should never be energized except when mounted on its corresponding solenoid tube.

The solenoid coil must be connected to an electrical line with volts and Hertz the same as stamped on the coil. The supply circuits must be properly sized to give adequate voltage at the coil leads even when other electrical equipment is operating. The coil is designed to operate with line voltage from 85% to 110% of rated coil voltage. Operating with a coil voltage above or below these limits may result in coil burnout. Also, operating with a coil voltage below the limit will definitely result in lowering the valve’s maximum opening pressure differential. Power consumption during normal operation will be 18.2 watts or less,

CK 5	1-1/4" TO 4"
PRESSURE BEARING COMPONENTS	
COMPONENT DESCRIPTION	MATERIAL
BODY	DUCTILE IRON GGG 40.3
BODY, A2D DN	DUCTILE IRON GGG 40.3
BONNET, A4W	DUCTILE IRON GGG 40.3
COVER TOP	DUCTILE IRON GGG 40.3
ADAPTER, 1-1/4 CK5 DN	DUCTILE IRON GGG 40.3

**For replacement parts and prices, consult  
PARTS KITS LIST PRICE SCHEDULE  
INDUSTRIAL AND FLO-CON (PK)**

ITEM	DESCRIPTION
1	Seal Cap
2	Gasket
3	Nut, Packing
4	Packing
5	Washer
6	Stem, Adjusting
8	Bonnet
9	Name Plate
10	Screw
11	Bolt, Bonnet
12	Spring Rest, Upper
13	Spring, Range
14	Spring Rest, Lower
15	Diaphragm Follower
16	Gasket
17	Diaphragm
18	Pilot Seat
19	Gasket
20	Screw
21	Cover
22	Gasket
23	Adapter
24	Gasket
25	Piston
26	Spring
27	Stem, Manual Opening
28	Body
29	Screw
30	Washer
31	Packing
32	Nut, Packing
33	Gasket
34	Seal Cap
35	Cover, Bottom
37	Gasket
39	Disc Strainer Assembly
40	Tube
41	Plunger Asm
42	Seat
43	O-Ring
44	Body, Solenoid
46	Screw
48	Body, Pilot
49	Screw
50	O-Ring

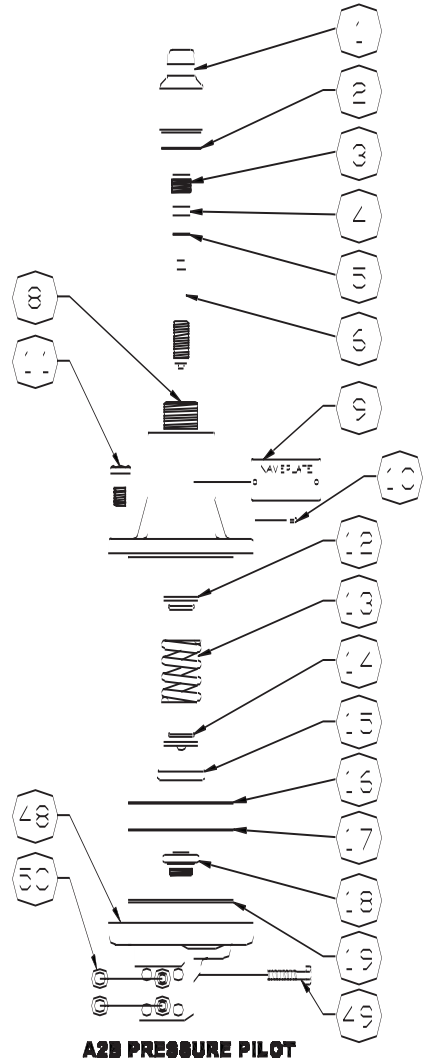
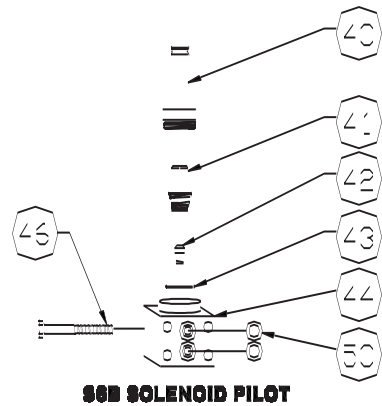
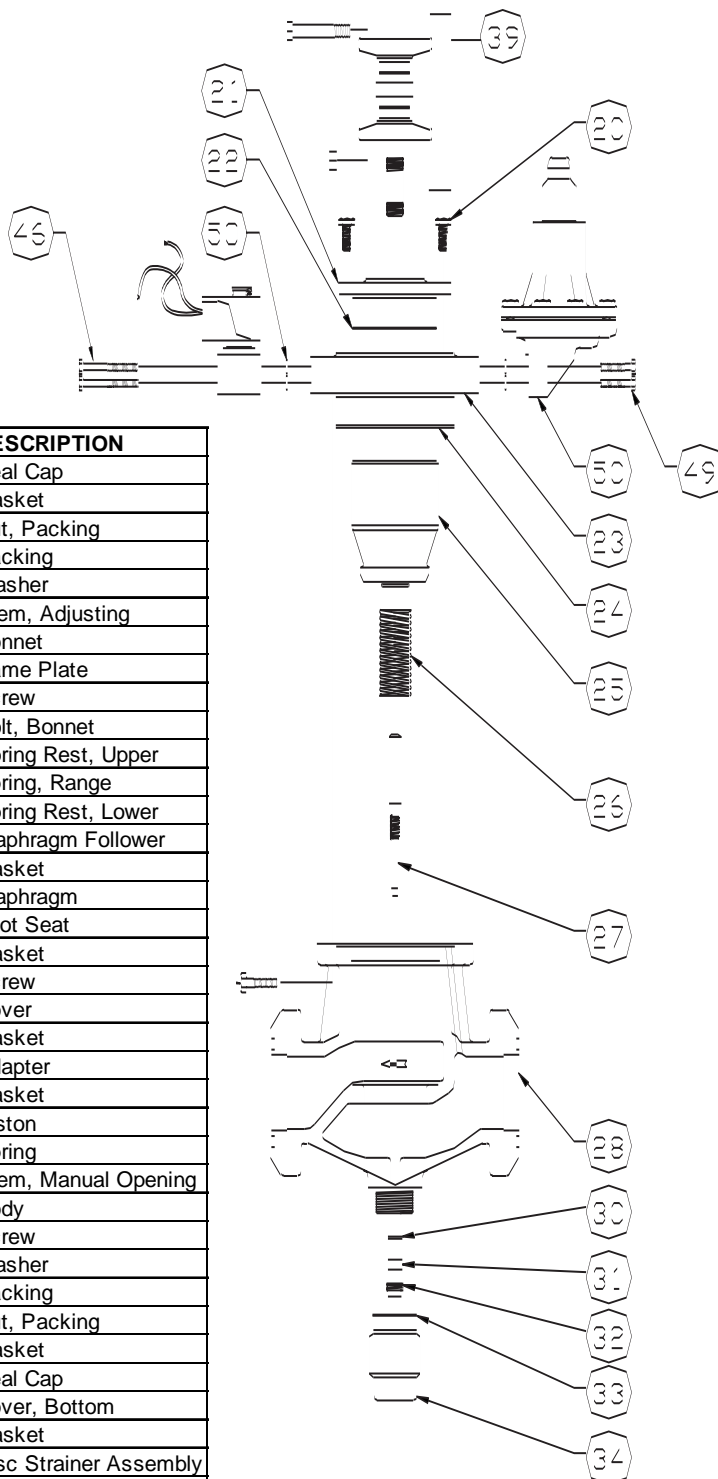

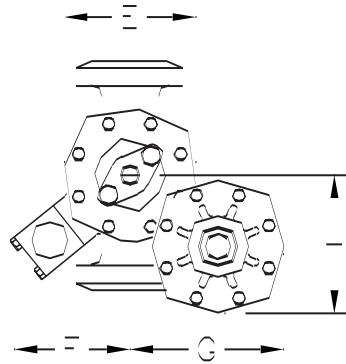

1-1/4" thru 4"

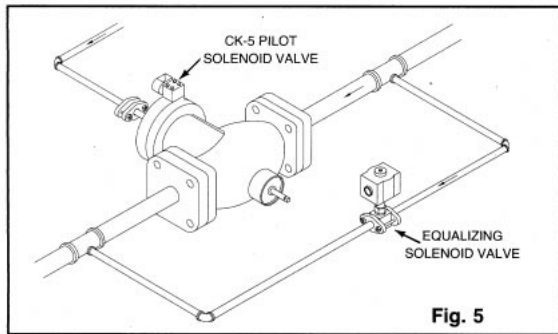
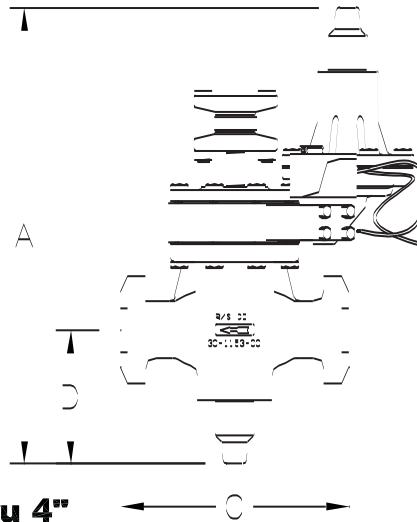

Fig. 5

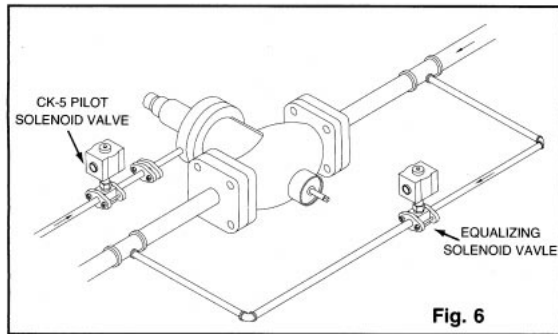

Fig. 6

**INSTALLATION**

BOLT TORQUETABLE		
ITEM	PORT SIZE	TORQUE
7/16" Flange Bolt	1/2"	28 ft lb
5/8" Flange Bolt	3/4" - 2"	85 ft lb
3/4" Flange Bolt	2-1/2" - 3"	105 ft lb
7/8" Flange Bolt	4"	150 ft lb
5/16" - 18 Bonnet Bolt	3/4" - 4"	15 ft lb
5/16" - 18 Adapter Bolt	3/4" - 2"	15 ft lb
5/8" - 11 Adapter Bolt	3" - 4"	75 ft lb
Bottom Cap	3/4" - 1-1/4"	150 ft lb
1/2" - 13 Bottom Cap Bolt	1-5/8" - 2-1/2"	50 ft lb
5/8" - 11 Bottom Cap Bolt	3" - 4"	75 ft lb

CK5 DIMENSIONS						
	1-1/4"	1-5/8"	2"	2-1/2"	3"	4"
A	17.6	19.7	19.7	20.2	24.9	27
B						
C	8	9.9	9.9	9.9	12.1	14.1
D	6.3	6.9	6.9	7.1	10.7	11.5
E	4.6	5.5	5.5	6.2	7	8.8
F	4.4	4.6	4.6	4.9	5.6	6.2
G	5.4	5.5	5.5	5.9	6.6	7.7
H	4.8	5.3	5.3	5.2	4.8	5.5

**WARRANTY**

All Refrigerating Specialties' products are warranted against defect in workmanship and materials for a period of one year from date of shipment from the factory. Unless otherwise approved in writing by Refrigerating Specialties this warranty is in force only when products are properly installed, maintained and operated for normal refrigeration application as specifically stated in Refrigerating Specialties catalogs or bulletins. Defective products, or parts thereof, returned to the factory with transportation charges prepaid will be replaced or repaired at Refrigerating Specialties' option, free of charge, F.O.B. factory, as long as they are found to be defective by factory inspection. Warranty does not cover products which have been altered or repaired in the field, damaged in transit, or which have suffered accidents, misuse, or abuse. Products disabled by dirt, or other foreign substances will not be considered defective.

THE EXPRESS WARRANTY SET FORTH ABOVE CONSTITUTES THE ONLY WARRANTY APPLICABLE TO REFRIGERATING SPECIALTIES PRODUCTS, AND IS IN LIEU OF ALL OTHER WARRANTIES, EXPRESS OR IMPLIED, WRITTEN OR ORAL, INCLUDING ANY WARRANTY OF MERCHANTABILITY, OR FITNESS FOR A PARTICULAR PURPOSE. No employee agent, dealer or other person is authorized to give any warranties on behalf of Refrigerating Specialties, nor to assume, for Refrigerating Specialties, any other liability in connection with any of its products.

**SAFE OPERATION (See Bulletin RSBCV)**

People doing any work on a refrigeration system must be qualified and completely familiar with the system and the valves involved, or all other precautions will be meaningless. This includes reading and understanding pertinent product bulletins and the current Bulletin RSBCV prior to installation or servicing work.