

Check Valve

Product Bulletin 50-13 C

Type: CK-3

Port Size: 13 - 25 mm ($\frac{1}{2}$ " - 1")

Design Pressure (MRPS): 27.6 bar (400 psig)



Purpose:

The Refrigerating Specialties CK-3 check valve prevents backward flow of high pressure refrigerant gases and liquid. The PTFE valve seat and stainless steel body allows the CK-3 to withstand corrosive environments associated in industrial refrigeration conditions.

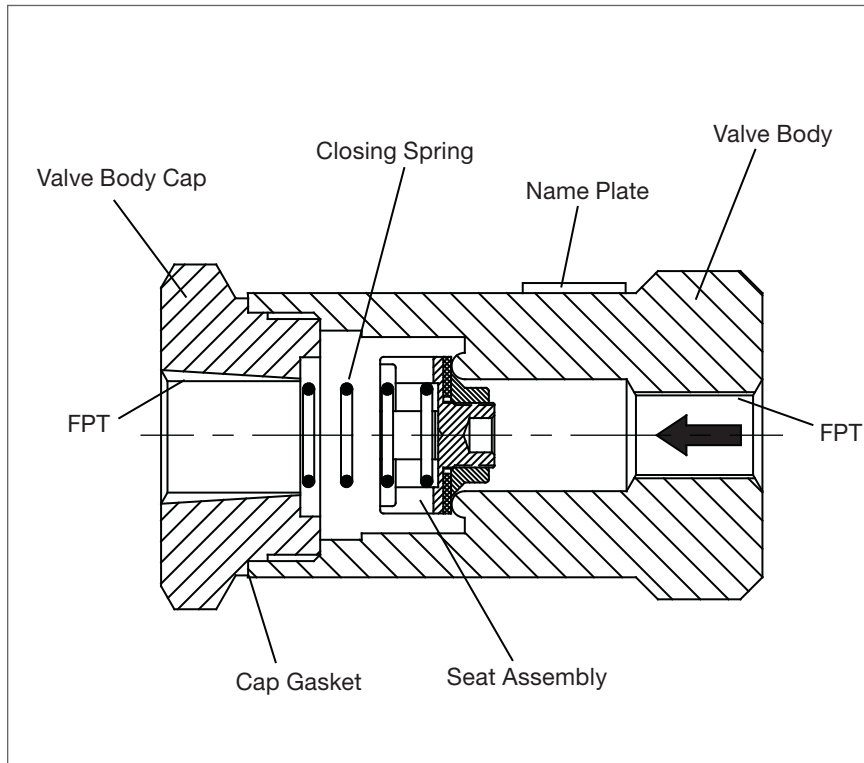

Contact Information:

Parker Hannifin Corporation
Refrigerating Specialties Division
2445 South 25th. Avenue
Broadview, IL 60155-3891

phone (708) 681-6300
fax (708) 681-6306

www.parker.com

Product Features:

- Suitable for Ammonia, R-22, R-507, R-134a, and other common refrigerants, certain oils and other fluids approved for use in refrigeration
- Small, Compact, Heavy Duty
- Stainless Steel Assembly
- Screwed Ends (FPT Connections)
- Spring Loaded
- Installs in any position
- Fluid Temperature Range: -30° to 105° C (-25° to 22° 0F)



ENGINEERING YOUR SUCCESS.

Description

The CK-3 is a compact, heavy duty, screwed end, in-line check valve suited for refrigerant flow control applications. The spring loaded check valve requires a minimum 0.34 bar (5 psi) pressure drop to overcome the spring force and lift the valve seat, allowing the check valve to be mounted in any position. The valve opens wide for flow in the arrow direction on the body of the valve. When flow reversal occurs the CK-3 valve closes quickly and reliably.

These check valves are ideally suited for branch hot gas lines from a single hot gas solenoid valve to prevent liquid cross-over between evaporators during refrigeration. They are also recommended for use in the hot gas connection from the drain pan to the evaporator to prevent drain pan frosting.

Installation

Protect inside of valve from dirt, chips and moisture during installation. Be sure to remove protective plugs from

Port Size		Kv	Cv
mm	in		
13	1/2"	8.1	9.5
20	3/4"	9.0	10.5
25	1"	9.8	11.5

CK-3 Specification Table

Safe Operation (See Bulletin RSBCV)

People doing any work on a refrigeration system must be qualified and completely familiar with the system and the Refrigerating Specialties Division valves involved, or all other precautions will be meaningless. This includes reading and understanding pertinent Refrigerating Specialties Division Product Bulletins and Safety Bulletin RSB prior to installation or servicing work.

Where cold refrigerant liquid lines are used, it is necessary that certain precautions be taken to avoid damage which could result from liquid expansion. Temperature increase in a piping section full of solid liquid will cause high pressure due to the expanding liquid which can possibly rupture a gasket, pipe or valve. All hand valves isolating such sections should be marked, warning against accidental closing, and must not be closed until the liquid is removed. Check valves must never be installed upstream of solenoid valves, or regulators with electric shut-off, nor should hand valves upstream of solenoid valves or downstream of check valves be closed until the liquid has been removed.

valve before installation. Install the valve in an accessible location for servicing. Check valves should always be installed at the outlet, never at the inlet of the valves. The valve must be installed with the flow arrow on the valve pointing in the direction of permissible fluid flow through the valve.

Caution

Do not install the check valve at the inlet of the solenoid valve, or a regulator with an electric shut-off feature. Do not install at the inlet of an outlet pressure regulator in a system where liquid may be trapped between the two valves.

Service Pointers

1. Failure to close (a) there may be dirt or chips on the PTFE disc of the plug assembly. Disassemble the valve by removing the valve body cap, main valve plug assembly and closing spring. Clean all parts thoroughly and reassemble. If any parts are damaged, the valve should be replaced.
2. Leakage through the valve – see above.

Dimension	13 mm (1/2")		20 mm (3/4")		25 mm (1")	
	mm	in	mm	in	mm	in
A	58.42	2.30	58.42	2.30	58.42	2.30
B	95.76	3.77	95.76	3.77	105.41	4.15
C	50.80	2.00	50.80	2.00	50.80	2.00

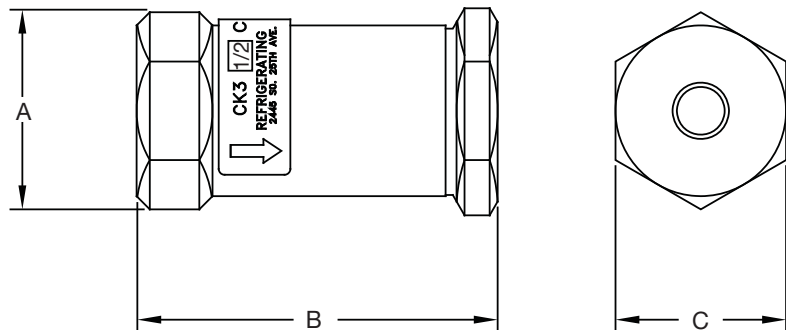

CK-3 Dimension Table

It is advisable to properly install relief devices in any section where liquid expansion could take place. Avoid all piping or control arrangements which might produce thermal or pressure shock.

For the protection of people and products, all refrigerant must be removed from the section to be worked on before a valve, strainer, or other device is opened or removed. Flanges with ODS connections are not suitable for ammonia service.

Warranty

All Refrigerating Specialties products are under warranty against defects in workmanship and materials for a period of one year from date of shipment from factory. This warranty is in force only when products are properly installed, field assembled, maintained, and operated in use and service as specifically stated in Refrigerating Specialties Catalogs or Bulletins for normal refrigeration applications, unless otherwise approved in writing by the Refrigerating Specialties Division. Defective products, or parts thereof returned to the factory with transportation charges prepaid

and found to be defective by factory inspection, will be replaced or repaired at Refrigerating Specialties option, free of charge, F.O.B. factory. Warranty does not cover products which have been altered, or repaired in the field, damaged in transit, or have suffered accidents, misuse, or abuse. Products disabled by dirt or other foreign substances will not be considered defective.

The express warranty set forth above constitutes the only warranty applicable to Refrigerating Specialties products, and is in lieu of all other warranties, expressed or implied, written including any warranty of merchantability, or fitness for a particular purpose. In no event is Refrigerating Specialties responsible for any consequential damages of any nature whatsoever. No employee, agent, dealer or other person is authorized to give any warranties on behalf of Refrigerating Specialties, nor to assume, for Refrigerating Specialties, any other liability in connection with any of its products.

