

Dual Position Gas Powered Suction Stop Valve Type CK-2D DN

Port Size: 50mm to 100mm (2" – 4")
**Suitable For: Ammonia, R-22 and
Other Common Refrigerants**

Features

- Economical Solution to Evaporator Equalization after Defrost
- Low Pressure Drop
- Heavy Return Spring
- Manual Opening Stem
- Integrated S6B pilot solenoids
- Standard Coil Housing Meets NEMA 3R and 4 - Rain Tight
- Normally Open
- Maximum Rated Pressure (MRP): 28 bar (406 psig)
- Body Material made from ggg40.3
- Complies with PED 97/23/EC

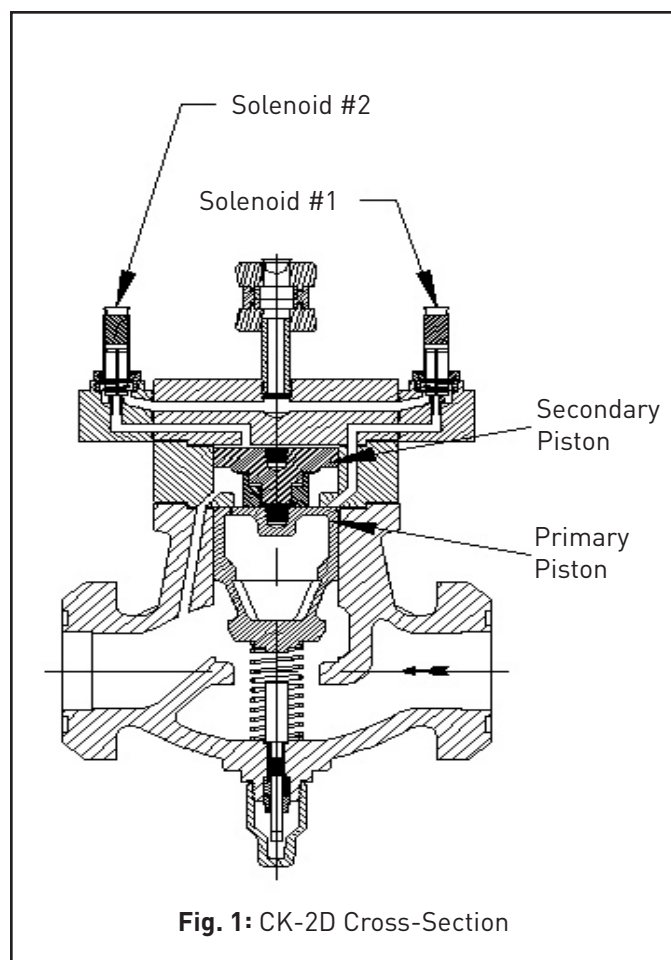

Fig. 1: CK-2D Cross-Section

Bulletin DN 50 -24



September 2007

Installation, Service, and Parts Information

Description

The CK-2D is based on the same valve body and operational principles as the standard CK-2 valves making for easy field replacements. This heavy duty gas-powered valve is suitable for ammonia, R-22, other refrigerants, certain oils and other fluids approved for use in refrigeration. The CK-2D is a pilot operated, dual-position valve. The CK-2D is a normally open valve and will open on power failure. This valve is equipped with a manual opening stem.

The Type CK-2D Gas-Powered Valve is furnished with FPT Internal NPT (U.S. Standard Taper Pipe Thread), Socket Weld, Weld Neck or ODS (solders over copper tubing of given diameter) connections. The valve may be easily removed from between the flanges for servicing.

Purpose

These valves are employed as a low pressure drop, gas-powered suction stop valve for low temperature evaporators. Because of the return spring, there is no line pressure drop required to open the valve during refrigeration. This allows for a minimal pressure drop penalty in the suction line. The CK-2D will positively close the suction line allowing for defrost to occur. The dual position feature allows the evaporator pressure to equalize through the CK-2D with the suction pressure after a defrost cycle has occurred. The intermediate stage allows for this equalization to occur in a controlled manner without the need for an externally piped equalizing solenoid.

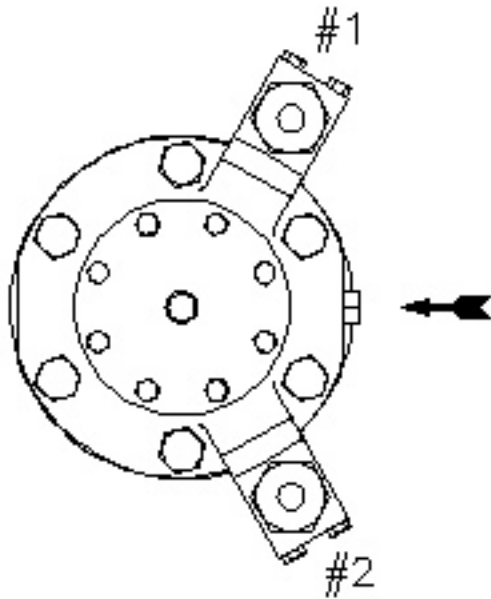

Fig. 2: CK-2D Top View

Coil State	Valve Position
#1 De-Energized	Full Open
#2 De-Energized	
#1 Energized	Full Close
#2 Energized	
#1 De-Energized	Equalize
#2 Energized	

Principles of Operation

The CK-2D is a normally open valve which uses discharge gas to power the valve closed. For closing of the CK-2D, either energize both solenoid coils simultaneously, or energize solenoid coil #2 initially allowing condenser gas pressure or pressure from another source to act on the secondary piston forcing it down and closing the valve to the 1st stage. Then while keeping solenoid coil #2 energized, solenoid coil #1 is energized allowing gas pressure to act on the primary piston forcing it down, compressing the spring fully, and firmly seating on the valve seat bead. Refrigerating Specialties recommends utilizing an oil free source of gas such as that from the top of the high-pressure receiver, or rotary screw compressor system. The valve will not close unless pressure above the pistons exceeds the downstream pressure by at least .35 bar (5 psi). If an attempt is made to fully close the valve by only energizing solenoid coil #1, a far greater amount of pressure will be required to act upon the main piston.

For line equalization solenoid coil #1 is de-energized, while solenoid coil #2 remains energized, allowing the primary piston to move up to the bottom of the secondary

piston, allowing for evaporator equalization after derost. The length of time the valve is left in the equalization position is controlled by the time set in the equalization stage on the defrost controller.

Manual Lift Stem

If it is desired to hold open the CK-2D Dual Position Suction Stop Valve manually, remove the Sealing cap and turn the Lifting Stem inward as far as possible. Valve cannot close now until the Seat Lift Stem is once again turned out.

Installation

Protect inside of valve from dirt and chips during installation. In low temperature applications the CK-2D should be powered with an oil free source of gas such as that from the top of the high-pressure receiver or a rotary screw compressor system. The CK-2D should not be used at temperatures below -30°C (-25°F) if an oil free source of high-pressure gas cannot be utilized to power the valve.

The CK-2D Dual Position Suction Stop Valve may be installed on its side or vertically upright in either vertical or horizontal pipe lines. When used on suction lines the arrow on the valve body should point in the direction of normal fluid flow. When used on either gas or liquid legs of a flooded evaporator the arrow on the valve body should point from the evaporator to the surge drum. The solenoid sequencing should be as follows (fig 2).

To fully close the valve: Energize both solenoid coils simultaneously, or energize solenoid coil #2, then solenoid coil #1.

For line equalization: Keep solenoid coil #2 energized while de-energizing solenoid coil #1. This will allow the valve to open the equivalent of a 1" valve.

Full open: De-energize both solenoid coils.

A wiring diagram for the R/S Defrost Controller is provided at the back of the bulletin.

Electrical

The Refrigerating Specialties Division molded water resistant solenoid coil is designed for long life and powerful opening force. The standard coil housing meets NEMA 3R and 4 requirements. This sealed construction can with stand direct contact with moisture and ice. The coil housing far exceeds the requirements of NEMA standard ICS, 1-110.57 salt spray test for rust resistance.

By definition, Class "F" coil construction will permit coil temperatures, as measured by resistance method, as high as 130° C (226° F). Final coil temperatures are a function of both fluid and ambient temperatures.

The higher fluid temperatures require lower ambient temperatures so the maximum coil temperature is not exceeded. Conversely, low fluid temperatures permit higher ambient temperatures.

The molded Class "F" coil is available from stock with most standard voltages. However, coils are available for other voltages and frequencies, as well as for direct current. Coils are also available as transformer type with a 6 volt secondary winding for use with the Refrigerating Specialties Division Pilot Light Assembly (see current copy of Bulletin 60-10, "Pilot Light Assembly and Solenoid Transformer Coil").

The solenoid coil must be connected to electrical lines with volts and Hertz same as stamped on coil. The supply circuits must be properly sized to give adequate voltage at the coil leads even when other electrical equipment is operating. The coil is designed to operate with line voltage from 85% to 110% of rated coil voltage. Operating with a line voltage above or below these limits may result in coil burnout. Also, operating with line voltage below the limit will definitely result in lowering the valve opening pressure differential. Power consumption during normal operation will be 33 watts or less.

Service Pointers

1. Failure to close:

- (a) One, or both pilot solenoids are not operating due to low voltage or solenoid coil burnout.
- (b) Dirt lodged between one of the valve pistons and the cylinder wall (disassemble and remove all dirt and burrs).
- (c) Manual lift stem is turned in, thereby mechanically holding the pistons in the open position.
- (d) Strainer/Disc in the Pilot line Flanges may be plugged (Remove and clean).
- (e) Pilot pressure source is not high enough; must be at least .35 bar (5 psi) above the main valve downstream pressure.
- (f) Solenoid coils are not being energized in the proper sequence.

2. Failure to open:

- (a) Dirt lodged between the valve pistons and the cylinder walls (Disassemble and remove dirt and burrs).
- (b) Main valve spring may be broken (replace spring).
- (c) Pressures between remote pressure source and main valve downstream pressures are not equalizing. Check for leakage through the pilot solenoids. Check for backward installation of the CK-2D preventing the equalization with downstream pressure.
- (d) Viscous oil can prevent the valve from opening.

3. Leakage through valve when closed:

- (a) There are dirt or chips under the main valve piston. Disassemble valve and clean thoroughly. Replace entire main valve piston and lap grind piston face into valve and seat bead if necessary

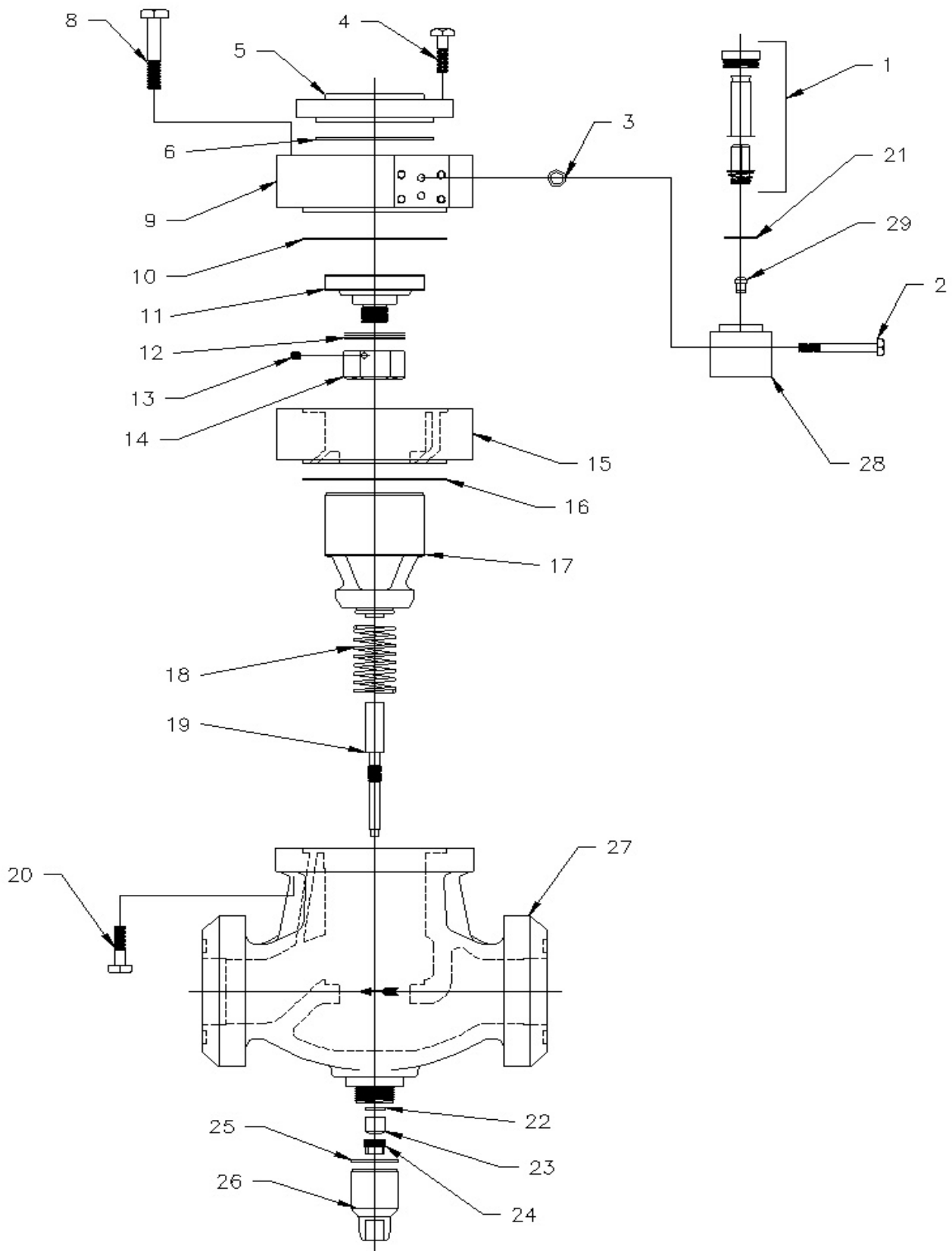
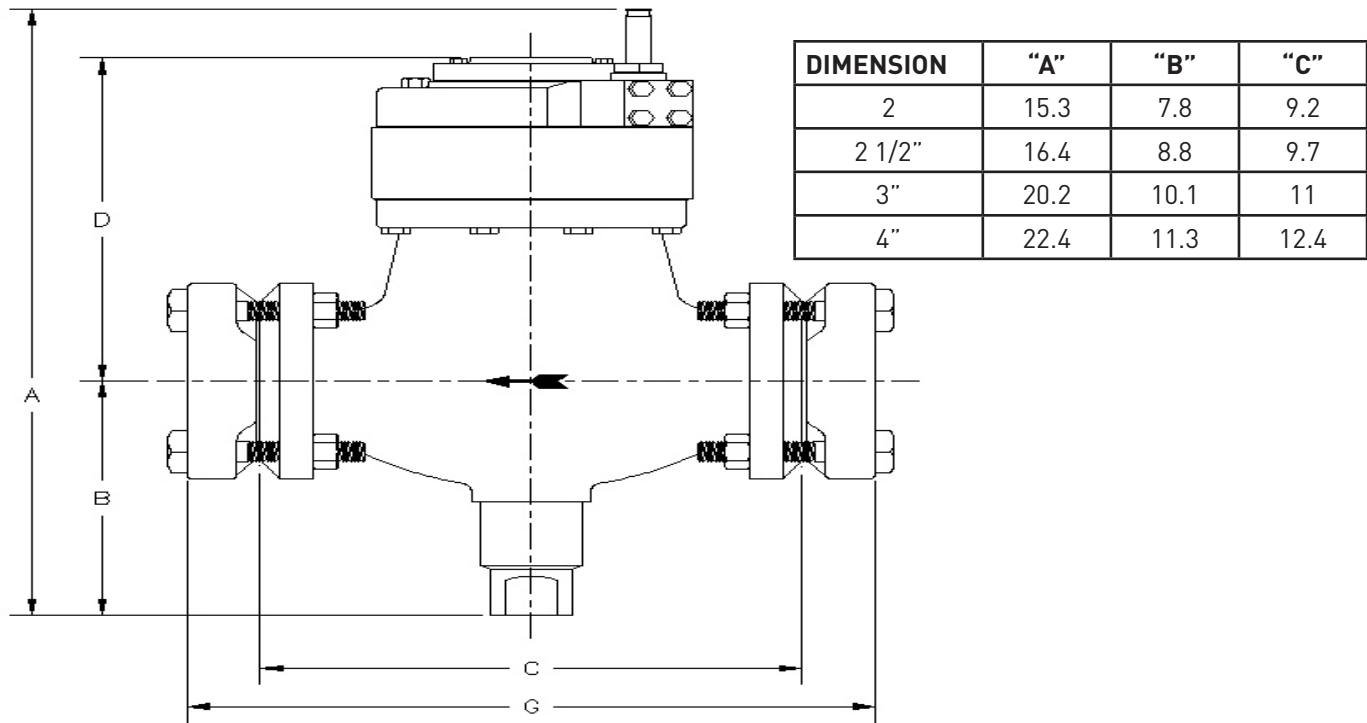

Fig. 3: CK-2D Exploded

ITEM	DESCRIPTION	QTY	CK-2D KIT NO. FOR VALVE SIZE			
			2"	2 1/2"	3"	4"
16	Gasket, Body	1	Only With Kit	Only With Kit	Only With Kit	Only With Kit
17	Piston Plug	1				
17,16	Piston Plug Kit	1	201139	201117	201127	201226
19	Opening Stem	1	Only With Kit	Only With Kit	Only With Kit	Only With Kit
22	Washer, Flat	1				
23	Packing, Stem	1				
19,22,23	Opening Stem Kit	1	201133	201118	201216	201213
25	Gasket, Seal Cap	1	Only With Kit	Only With Kit	Only With Kit	Only With Kit
26	Seal Cap	1				
25,26	Seal Cap Kit	1	202110	202114	202111	
23	Packing, Stem	1	Only With Kit	Only With Kit	Only With Kit	Only With Kit
24	Packing Nut, Stem	1				
23,24	Packing Kit	1	202100		202101	
10	Gasket, Adapter	1	Only With Kit	Only With Kit	Only With Kit	Only With Kit
11	Piston, Top	1				
12	Spacer, Piston	3				
13	Set Screw, Piston	1				
14	Nut, Piston	1				
10-14	Piston Kit	1	208305	208306	208307	208308
6	Gasket, Cover	1	Only With Kit	Only With Kit	Only With Kit	Only With Kit
8	Bolt, Adapter	6				
10	Gasket, Adapter	1				
11	Piston, Top	1				
12	Spacer, Piston	3				
13	Set Screw, Piston	1				
14	Nut, Piston	1				
15	Bore Plate	1				
16	Gasket, Body	1				
20	Bolt, Body	8				
6,8,10-16,20	Piston/Bore Plate Kit	1				
3	O-ring	4	Only With Kit	Only With Kit	Only With Kit	Only With Kit
4	Bolt, Cover	8				
5	Cover	1				
6	Gasket, Cover	1				
8	Bolt, Adapter	8				
9	Adapter	1				
10	Gasket, Adapter	1				
3-6,8-10	Adapter/Cover Kit	1	208391	208392	208528	208529
2	Bolt	4	Only With Kit	Only With Kit	Only With Kit	Only With Kit
3	O-ring	2				
2,3	Bolt/O-ring Kit	1	201574	201574	201574	201574
1	Plunger/Tube Asm	1	Only With Kit	Only With Kit	Only With Kit	Only With Kit
21	Solenoid Tube O-Ring	1				
29	Seat	1				
1,21,29	Plunger/Seat Kit	1	204707	204707	204707	204707
3,6,10,16,21,25	Gasket/O-ring Kit	1	208317	208318	208319	208320



PORT SIZE		A		B		C		D		E		F		G		H		J	
mm	in.	mm	in.	mm	in.	mm	in.	mm	in.	mm	in.	mm	in.	mm	in.	mm	in.	mm	in.
50	2	389	15.3	139.7	5.5	251	9.9	198	7.8	234	9.2	371	14.6	307	12.1	15	0.6	38	1.5
65	2.5	417	16.4	142.2	5.6	251	9.9	224	8.8	246	9.7	401	15.8	331	13	25	1	43	1.7
75	3	513	20.2	216	8.5	311	12.2	257	10.1	279	11	478	18.8	389	15.3	29	1.1	48	1.9
100	4	569	22.4	217	8.6	359	14.1	287	11.3	315	12.4	571	22.5	450	17.7	32	1.3	55	2.2

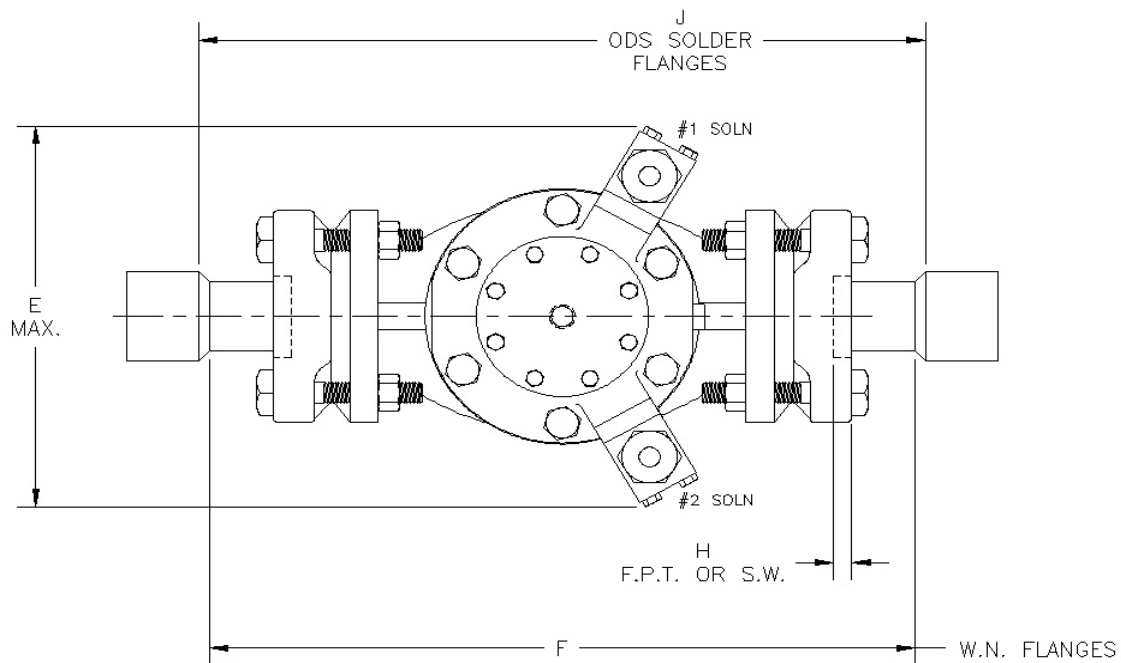

Fig. 4: CK-2D Dimensions

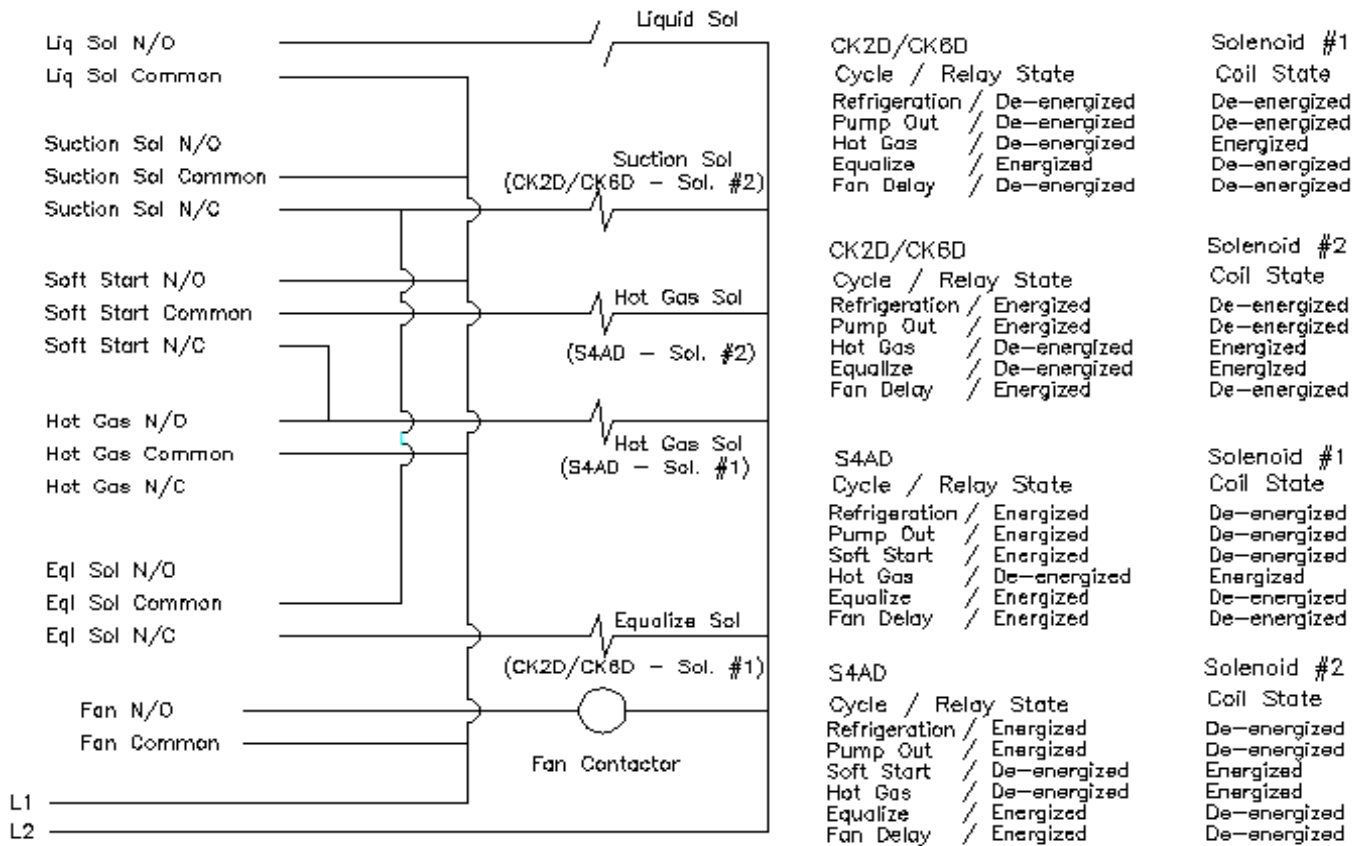

Fig. 5: R/S Defrost Controller Wiring Diagram CK-2D/CK-6D Line Equalization, S4AD Soft Start

Note: Wiring diagram above is for R/S controller only. If other manufacturer's controller is used, please consult their wiring diagram.

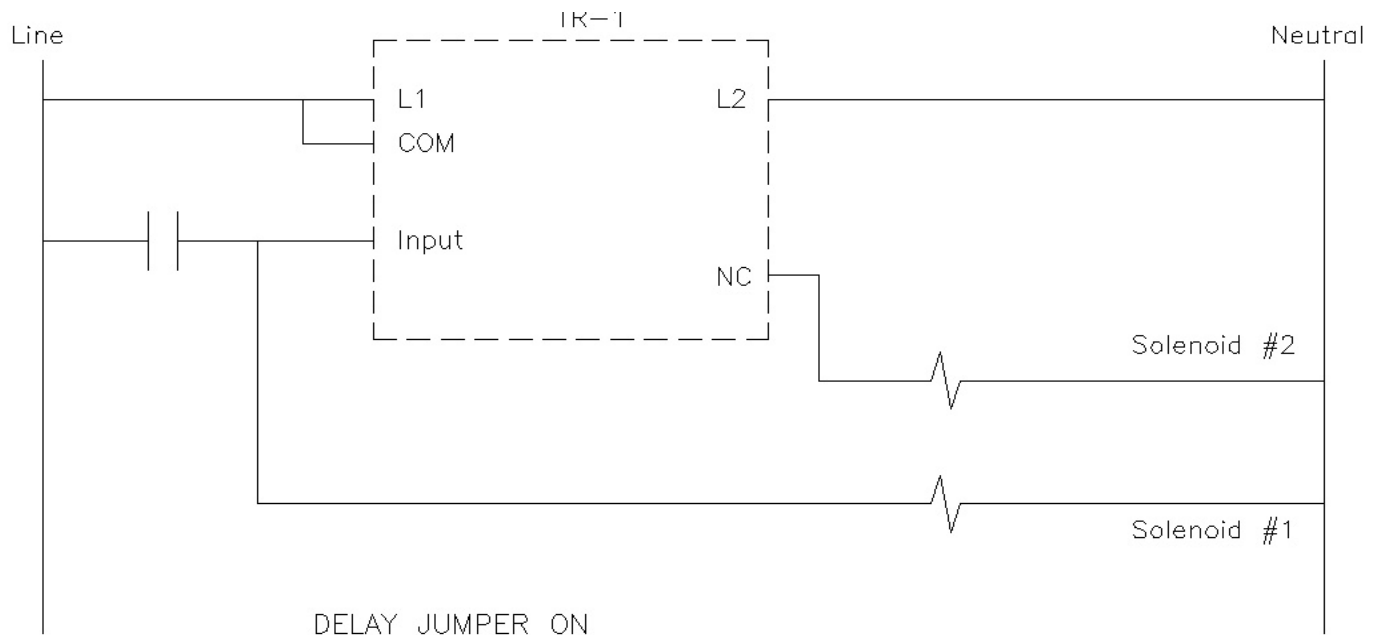

Fig. 5: R/S Adjustable Time Delay Wiring Diagram Valve Sequencing - Line Equalization on Opening

Note: On slow opening applications, solid state relay is available. Please consult factory

Safe Operation (see also Bulletin RSB)

People doing any work on a refrigeration system must be qualified and completely familiar with the system and the Refrigerating Specialties Division valves involved, or all other precautions will be meaningless. This includes reading and understanding pertinent Refrigerating Specialties Division product Bulletins and Safety Bulletin RSB prior to installation or servicing work.

Where cold refrigerant liquid lines are used, it is necessary that certain precautions be taken to avoid damage which could result from liquid expansion. Temperature increase in a piping section full of solid liquid will cause high pressure due to the expanding liquid which can possibly rupture a gasket, pipe or valve. All hand valves isolating such sections should be marked, warning against accidental closing, and must not be closed until the liquid is removed. Check valves, or regulators with electric shutoff, nor should hand valves upstream of solenoid valves or downstream of check valves be closed until the liquid has been removed. It is advisable to properly install relief devices in any section where liquid expansion could take place.

Avoid all piping or control arrangements which might produce thermal or pressure shock.

For the protection of people and products, all refrigerant must be removed from the section to be worked on before a valve, strainer, or other device is opened or removed.

Flanges with ODS connections are not suitable for ammonia service.

Warranty

All Refrigerating Specialties Products are warranted against defect in workmanship and material for a period of one year from the date of shipments from the factory. This warranty is in force only when products are properly installed, field assembled, maintained and operated in use and service as specifically stated in Refrigerating Specialties Catalogs or Bulletins for normal refrigeration applications, unless otherwise approved in writing by Refrigerating Specialties Division. Defective products, or parts thereof, returned to the factory with transportation charges prepaid and found to be defective by factory inspection will be replaced or repaired at Refrigerating Specialties' option, free of charge, F.O.B. factory. Warranty does not cover products which have been altered or repaired in the field; damaged in transit, or have suffered accidents, misuse, or abuse. Products disabled by dirt, or other foreign substances will not be considered defective.

THE EXPRESS WARRANTY SET FORTH ABOVE CONSTITUTES THE ONLY WARRANTY APPLICABLE TO REFRIGERATING SPECIALTIES PRODUCTS, AND IS IN LIEU OF ALL OTHER WARRANTIES, EXPRESS OR IMPLIED, WRITTEN OR ORAL, INCLUDING AND WARRANTY OR MERCHANTABILITY, OR FITNESS FOR A PARTICULAR PURPOSE. No employee, agent, dealer or other person is authorized to give any warranties on behalf of Refrigerating Specialties, nor to assume, for Refrigerating Specialties, any other liability in connection with any of its products.