

# ATV212HD30N4

variable speed drive ATV212 - 30kW - 40hp -  
480V - 3ph - EMC - IP21

Product availability : Stock - Normally stocked in distribution facility



Price\* : 3,091.00 USD



## Main

|                              |                                |
|------------------------------|--------------------------------|
| Range of Product             | Altivar 212                    |
| Product or Component Type    | Variable speed drive           |
| Device short name            | ATV212                         |
| Product destination          | Asynchronous motors            |
| Product Specific Application | Pumps and fans in HVAC         |
| Assembly style               | With heat sink                 |
| Phase                        | 3 phase                        |
| Motor power kW               | 30 kW                          |
| Maximum Horse Power Rating   | 40 hp                          |
| [Us] rated supply voltage    | 380...480 V - 15...10 %        |
| Supply voltage limits        | 323...528 V                    |
| Supply frequency             | 50...60 Hz - 5...5 %           |
| EMC filter                   | Class C2 EMC filter integrated |
| Line current                 | 44.7 A 480 V<br>56.7 A 380 V   |

## Complementary

|                                  |  |
|----------------------------------|--|
| Apparent power                   | 44.6 kVA 380 V   |
| Prospective line I <sub>sc</sub> | 22 kA  |
| Continuous output current        | 58.5 A 380 V<br>58.5 A 460 V                             |
| Maximum transient current        | 64.4 A 60 s  |
| Speed drive output frequency     | 0.5...200 Hz   |
| Nominal switching frequency      | 8 kHz  |
| Switching frequency              | 6...16 kHz adjustable<br>8...16 kHz with derating factor |

\* Price is "List Price" and may be subject to a trade discount – check with your local distributor or retailer for actual price.

|                                    |   |
|------------------------------------|---|
| Speed range                        | 1...10  |
| Speed accuracy                     | +/- 10 % of nominal slip 0.2 Tn to Tn   |
| Torque accuracy                    | +/- 15 %  |
| Transient overtorque               | 120 % of nominal motor torque +/- 10 % 60 s   |
| Asynchronous motor control profile | Voltage/frequency ratio, automatic IR compensation (U/f + automatic Uo)<br>Flux vector control without sensor, standard<br>Voltage/frequency ratio, 5 points<br>Voltage/frequency ratio - Energy Saving, quadratic U/f<br>Voltage/frequency ratio, 2 points |
| Regulation loop                    | Adjustable PI regulator   |
| Motor slip compensation            | Not available in voltage/frequency ratio motor control<br>Automatic whatever the load<br>Adjustable   |
| Local signalling                   | for DC bus energized 1 LED (red)  |
| Output voltage                     | <= power supply voltage   |
| Isolation                          | Electrical between power and control  |
| Type of cable                      | Without mounting kit 1 IEC cable 113 °F (45 °C), copper 90 °C / XLPE/EPR<br>Without mounting kit 1 IEC cable 113 °F (45 °C), copper 70 °C / PVC<br>With UL Type 1 kit 3 UL 508 cable 104 °F (40 °C), copper 75 °C / PVC                                     |
| Electrical connection              | VIA, VIB, FM, FLA, FLB, FLC, RY, RC, F, R, RES terminal 0.00 in <sup>2</sup> (2.5 mm <sup>2</sup> ) / AWG 14<br>L1/R, L2/S, L3/T terminal 0.08 in <sup>2</sup> (50 mm <sup>2</sup> ) / AWG 1/0  |
| Tightening torque                  | 5.31 lbf.in (0.6 N.m) VIA, VIB, FM, FLA, FLB, FLC, RY, RC, F, R, RES)<br>212.42 lbf.in (24 N.m), 212 lb.in L1/R, L2/S, L3/T)  |
| Supply                             | Internal supply for reference potentiometer (1 to 10 kOhm) 10.5 V DC +/- 5 %, <10 A overload and short-circuit protection<br>Internal supply 24 V DC 21...27 V), <200 A overload and short-circuit protection   |
| Analogue input number              | 2   |
| Analogue input type                | VIA switch-configurable voltage 0...10 V DC 24 V max 30000 Ohm 10 bits<br>VIB configurable voltage 0...10 V DC 24 V max 30000 Ohm 10 bits<br>VIB configurable PTC probe 0...6 probes 1500 Ohm<br>VIA switch-configurable current 0...20 mA 250 Ohm 10 bits  |
| Sampling duration                  | 2 ms +/- 0.5 ms F discrete<br>2 ms +/- 0.5 ms R discrete<br>2 ms +/- 0.5 ms RES discrete<br>3.5 ms +/- 0.5 ms VIA analog<br>22 ms +/- 0.5 ms VIB analog   |
| Response time                      | FM 2 ms +/- 0.5 ms analog<br>FLA, FLC 7 ms +/- 0.5 ms discrete<br>FLB, FLC 7 ms +/- 0.5 ms discrete<br>RY, RC 7 ms +/- 0.5 ms discrete  |
| Accuracy                           | +/- 0.6 % VIA) for a temperature variation 60 °C<br>+/- 0.6 % VIB) for a temperature variation 60 °C<br>+/- 1 % FM) for a temperature variation 60 °C   |
| Linearity error                    | VIA +/- 0.15 % of maximum value input<br>VIB +/- 0.15 % of maximum value input<br>FM +/- 0.2 % output   |
| Analogue output number             | 1   |
| Analogue output type               | FM switch-configurable voltage 0...10 V DC 7620 Ohm 10 bits<br>FM switch-configurable current 0...20 mA 970 Ohm 10 bits   |
| Discrete output number             | 2   |
| Discrete output type               | Configurable relay logic FLA, FLC) NO - 100000 cycles<br>Configurable relay logic FLB, FLC) NC - 100000 cycles<br>Configurable relay logic RY, RC) NO - 100000 cycles   |
| Minimum switching current          | 3 mA 24 V DC configurable relay logic   |
| Maximum switching current          | 5 A 250 V AC resistive cos phi = 1 L/R = 0 ms FL, R)<br>5 A 30 V DC resistive cos phi = 1 L/R = 0 ms FL, R)<br>2 A 250 V AC inductive cos phi = 0.4 L/R = 7 ms FL, R)<br>2 A 30 V DC inductive cos phi = 0.4 L/R = 7 ms FL, R)                              |
| Discrete input type                | F programmable 24 V DC level 1 PLC 4700 Ohm<br>R programmable 24 V DC level 1 PLC 4700 Ohm<br>RES programmable 24 V DC level 1 PLC 4700 Ohm   |
| Discrete input logic               | Positive logic (source) F, R, RES), <= 5 V, >= 11 V<br>Negative logic (sink) F, R, RES), >= 16 V, <= 10 V   |

|  |  |
|--|--|
| Acceleration and deceleration ramps        | Linear adjustable separately from 0.01 to 3200 s<br>Automatic based on the load  |
| Braking to standstill                      | By DC injection  |
| Protection type                            | Overheating protection: drive<br>Thermal power stage drive<br>Short-circuit between motor phases: drive<br>Input phase breaks: drive<br>Overcurrent between output phases and earth: drive<br>Overvoltages on the DC bus: drive<br>Break on the control circuit: drive<br>Against exceeding limit speed: drive<br>Line supply overvoltage and undervoltage drive<br>Line supply undervoltage: drive<br>Against input phase loss: drive<br>Thermal protection: motor<br>Motor phase break: motor<br>With PTC probes motor |
| Dielectric strength                        | 3535 V DC between earth and power terminals<br>5092 V DC between control and power terminals   |
| Insulation resistance                      | >= 1 mOhm 500 V DC for 1 minute  |
| Frequency resolution                       | Display unit: 0.1 Hz<br>Analog input: 0.024/50 Hz  |
| Communication Port Protocol                | APOGEE FLN<br>Modbus<br>BACnet<br>METASYS N2<br>LonWorks   |
| Connector Type                             | 1 open style<br>1 RJ45   |
| Physical interface                         | 2-wire RS 485  |
| Transmission frame                         | RTU  |
| Transmission Rate                          | 9600 bps or 19200 bps  |
| Data format                                | 8 bits, 1 stop, odd even or no configurable parity   |
| Type of polarization                       | No impedance   |
| Number of addresses                        | 1...247  |
| Communication Service                      | Read device identification (43)<br>Monitoring inhibitible<br>Time out setting from 0.1 to 100 s<br>Read holding registers (03) 2 words maximum<br>Write single register (06)<br>Write multiple registers (16) 2 words maximum  |
| Option card                                | Communication card for LonWorks  |
| Operating position                         | Vertical +/- 10 degree   |
| Maximum Width                              | 9.45 in (240 mm)   |
| Maximum Height                             | 16.54 in (420 mm)  |
| Maximum Depth                              | 8.43 in (214 mm)   |
| Net Weight                                 | 58.20 lb(US) (26.4 kg)   |
| Power dissipation in W                     | 847 W  |
| Air flow                                   | 76611.27 Gal/hr(US) (290 m3/h)   |
| Functionality                              | Mid  |
| Specific application                       | HVAC   |
| IP degree of protection                    | IP21   |
| Variable speed drive application selection | Building - HVAC Compressor for scroll<br>Building - HVAC Fan<br>Building - HVAC Pump   |
| Motor power range AC-3                     | 30...50 kW 380...440 V 3 phase<br>30...50 kW 480...500 V 3 phase   |
| Motor starter type                         | Variable speed drive   |

## Environment

|                               |   |
|-------------------------------|---|
| Electromagnetic compatibility | Electrostatic discharge immunity test level 3 conforming to IEC 61000-4-2<br>Radiated radio-frequency electromagnetic field immunity test level 3 conforming to IEC 61000-4-3 |
|-------------------------------|---|

Electrical fast transient/burst immunity test level 4 conforming to IEC 61000-4-4  
 1.2/50  $\mu$ s - 8/20  $\mu$ s surge immunity test level 3 conforming to IEC 61000-4-5  
 Conducted radio-frequency immunity test level 3 conforming to IEC 61000-4-6  
 Voltage dips and interruptions immunity test conforming to IEC 61000-4-11

|                                       |   |
|---------------------------------------|---|
| Pollution degree                      | 3 IEC 61800-5-1   |
| IP degree of protection               | IP20 on upper part without blanking plate on cover EN/IEC 61800-5-1<br>IP20 on upper part without blanking plate on cover EN/IEC 60529<br>IP21 EN/IEC 61800-5-1<br>IP21 EN/IEC 60529<br>IP41 on upper part conforming to EN/IEC 61800-5-1<br>IP41 on upper part conforming to EN/IEC 60529  |
| Vibration resistance                  | 1.5 mm 3...13 Hz)EN/IEC 60068-2-6<br>1 gn 13...200 Hz)EN/IEC 60068-2-8  |
| Shock resistance                      | 15 gn 11 ms IEC 60068-2-27  |
| Environmental characteristic          | Classes 3C1 IEC 60721-3-3<br>Classes 3S2 IEC 60721-3-3  |
| Noise level                           | 59.9 dB 86/188/EEC  |
| Operating altitude                    | 3280.84...9842.52 ft (1000...3000 m) limited to 2000 m for the Corner Grounded distribution network with current derating 1 % per 100 m<br><= 3280.84 ft (1000 m) without derating  |
| Relative humidity                     | 5...95 % without condensation IEC 60068-2-3<br>5...95 % without dripping water IEC 60068-2-3  |
| Ambient air temperature for operation | 14...104 °F (-10...40 °C) without derating)<br>104...122 °F (40...50 °C) with derating factor)  |
| Ambient Air Temperature for Storage   | -13...158 °F (-25...70 °C)  |
| Standards                             | EN 61800-3 environments 2 category C1<br>EN 61800-3 category C2<br>IEC 61800-5-1<br>EN 61800-3 environments 1 category C1<br>EN 61800-3<br>IEC 61800-3 environments 2 category C2<br>EN 61800-5-1<br>EN 61800-3 environments 1 category C3<br>EN 61800-3 environments 2 category C3<br>EN 55011 class A group 1<br>EN 61800-3 environments 1 category C2<br>IEC 61800-3 environments 1 category C2<br>EN 61800-3 environments 2 category C2<br>IEC 61800-3 environments 2 category C1<br>IEC 61800-3<br>IEC 61800-3 category C2<br>IEC 61800-3 environments 1 category C3<br>IEC 61800-3 environments 1 category C1<br>EN 61800-3 category C3<br>IEC 61800-3 category C3<br>UL Type 1<br>IEC 61800-3 environments 2 category C3 |
| Product Certifications                | NOM 117<br>C-tick<br>UL<br>CSA  |
| Marking                               | CE  |

### Ordering and shipping details

|                       |                                     |
|-----------------------|-------------------------------------|
| Category              | 22158 - ATV212 30 - 100 HP 460 VOLT |
| Discount Schedule     | CP4D                                |
| GTIN                  | 03606480322556                      |
| Nbr. of units in pkg. | 1                                   |
| Package weight(Lbs)   | 52.47 lb(US) (23.8 kg)              |
| Returnability         | Yes                                 |
| Country of origin     | CN                                  |

### Packing Units

|                        |     |
|------------------------|-----|
| Unit Type of Package 1 | PCE |
|------------------------|-----|

|                  |                    |
|------------------|--------------------|
| Package 1 Height | 14.37 in (36.5 cm) |
| Package 1 width  | 15.55 in (39.5 cm) |
| Package 1 Length | 23.62 in (60 cm)   |

### Offer Sustainability

|                            |   |
|----------------------------|---|
| Sustainable offer status   | Green Premium product   |
| California proposition 65  | WARNING: This product can expose you to chemicals including: Lead and lead compounds, which is known to the State of California to cause cancer and birth defects or other reproductive harm. For more information go to <a href="http://www.P65Warnings.ca.gov">www.P65Warnings.ca.gov</a> |
| REACH Regulation           | <a href="#">REACH Declaration</a>   |
| EU RoHS Directive          | Pro-active compliance (Product out of EU RoHS legal scope)<br><a href="#">EU RoHS Declaration</a>   |
| Mercury free               | Yes   |
| RoHS exemption information | <a href="#">Yes</a>   |
| China RoHS Regulation      | <a href="#">China RoHS declaration</a>  |
| Environmental Disclosure   | <a href="#">Product Environmental Profile</a>   |
| Circularity Profile        | <a href="#">End of Life Information</a>   |
| WEEE                       | The product must be disposed on European Union markets following specific waste collection and never end up in rubbish bins.  |

### Contractual warranty

|          |           |
|----------|-----------|
| Warranty | 18 months |
|----------|-----------|

Dimensions

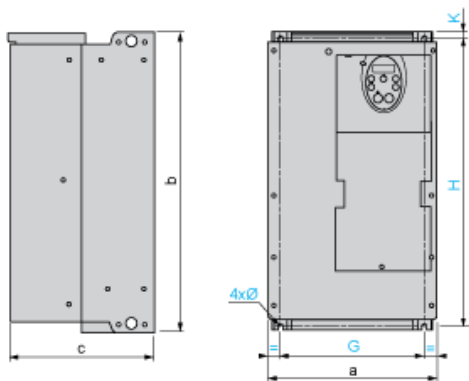

Dimensions in mm

| ATV212H                | a   | b   | c   | G   | H   | K  | Ø |
|------------------------|-----|-----|-----|-----|-----|----|---|
| D22M3X<br>D22N4, D30N4 | 240 | 420 | 214 | 206 | 403 | 10 | 6 |
| D37N4, D45N4           | 240 | 550 | 244 | 206 | 529 | 10 | 6 |

Dimensions in in.

| ATV212H                | a    | b     | c    | G    | H     | K    | Ø    |
|------------------------|------|-------|------|------|-------|------|------|
| D22M3X<br>D22N4, D30N4 | 9.45 | 16.54 | 8.43 | 8.11 | 15.87 | 0.39 | 0.24 |
| D37N4, D45N4           | 9.45 | 21.65 | 9.60 | 8.11 | 20.83 | 0.39 | 0.24 |

EMC mounting plate (supplied with drive)

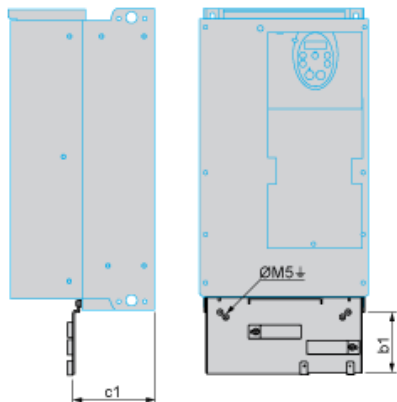

Dimensions in mm

| ATV212H                | b1  | c1  |
|------------------------|-----|-----|
| D22M3X<br>D22N4, D30N4 | 122 | 120 |
| D37N4, D45N4           | 113 | 127 |

Dimensions in in.

| ATV212H                | b1   | c1   |
|------------------------|------|------|
| D22M3X<br>D22N4, D30N4 | 4.80 | 4.72 |
| D37N4, D45N4           | 4.45 | 5.00 |

## Mounting Recommendations

### Clearance

Depending on the conditions in which the drive is to be used, its installation will require certain precautions and the use of appropriate accessories.

Install the unit vertically:

- Do not place it close to heating elements.
- Leave sufficient free space to ensure that the air required for cooling purposes can circulate from bottom to the top of the unit.

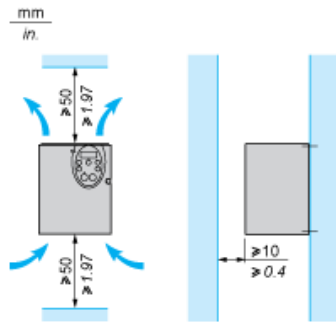

### Mounting Types

Type A mounting

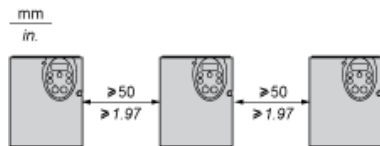

Type B mounting

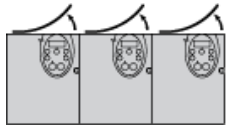

Type C mounting

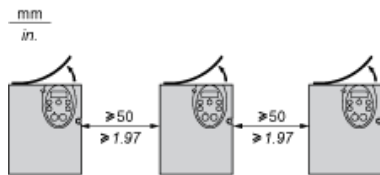

By removing the protective blanking cover from the top of the drive, the degree of protection for the drive becomes IP21. The protective blanking cover may vary according to the drive model, see opposite.

---

### Specific Recommendations for Mounting in an Enclosure

---

To help ensure proper air circulation in the drive:

- Fit ventilation grilles.
- Check that there is sufficient ventilation. If there is not, install a forced ventilation unit with a filter. The openings and/or fans must provide a flow rate at least equal to the drive's heat dissipation.
- Use special filters with UL Type 12/IP54 protection.
- Remove the blanking cover from the top of the drive.

### Sealed Metal Enclosure (IP54 Degree of Protection)

The drive must be mounted in a dust and damp proof enclosure in certain environmental conditions, such as dust, corrosive gases, high humidity with risk of condensation and dripping water, splashing liquid, etc. This enables the drive to be used in an enclosure where the maximum internal temperature reaches 50°C.

Recommended Wiring Diagram

3-Phase Power Supply

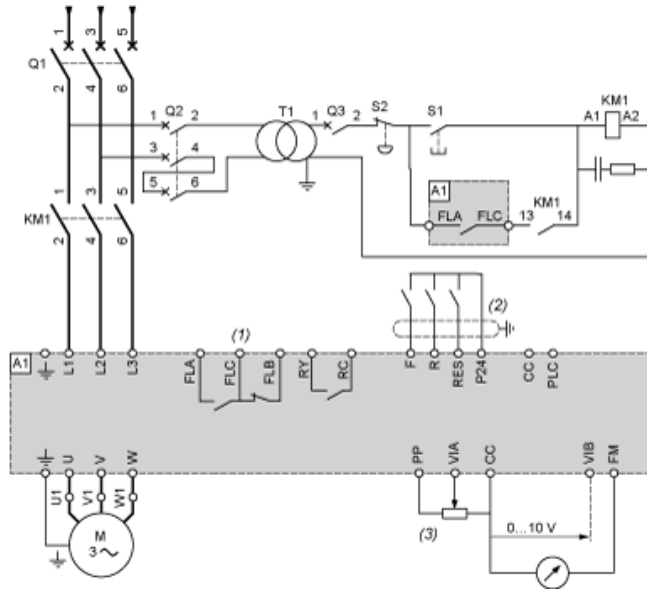

- A1: ATV 212 drive
- KM1: Contactor
- Q1: Circuit breaker
- Q2: GV2 L rated at twice the nominal primary current of T1
- Q3: GB2CB05
- S1, S2: XB4 B or XB5 A pushbuttons
- T1: 100 VA transformer 220 V secondary
- (1) Fault relay contacts for remote signalling of the drive status
- (2) Connection of the common for the logic inputs depends on the positioning of the switch (Source, PLC, Sink)
- (3) Reference potentiometer SZ1RV1202

NOTE: All terminals are located at the bottom of the drive. Install interference suppressors on all inductive circuits near the drive or connected on the same circuit, such as relays, contactors, solenoid valves, fluorescent lighting, etc.

Switches (Factory Settings)

Voltage/current selection for analog I/O (VIA and VIB)



Voltage/current selection for analog I/O (FM)



Selection of logic type

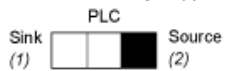

- (1) negative logic
- (2) positive logic

Other Possible Wiring Diagrams

Logic Inputs According to the Position of the Logic Type Switch

“Source” position

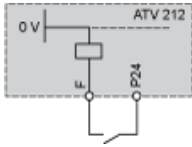

“Sink” position

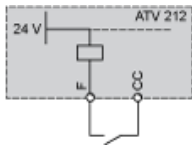

“PLC” position with PLC transistor outputs

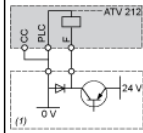

(1) PLC

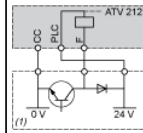

(1) PLC

2-wire control

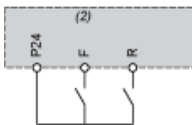

- F: Forward
- R: Preset speed
- (2) ATV 212 control terminals

3-wire control

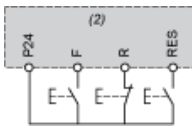

- F: Forward
- R: Stop
- RES: Reverse
- (2) ATV 212 control terminals

PTC probe

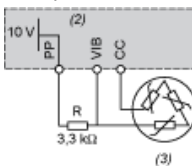

- (2) ATV 212 control terminals
- (3) Motor

Analogue Inputs

Voltage analog inputs

External +10 V



Analog input configured for current: 0-20 mA, 4-20 mA, X-Y mA

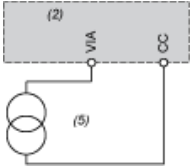

- (2) ATV 212 control terminals
- (5) Source 0-20 mA, 4-20 mA, X-Y mA

Analog input VIA configured as positive logic input ("Source" position)



- (2) ATV 212 control terminals

Analog input VIA configured as negative logic input ("Sink" position)

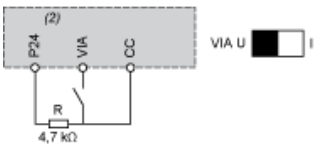

- (2) ATV 212 control terminals

Derating Curves

The derating curves for the drive nominal current ( $I_n$ ) depend on the temperature, the switching frequency and the mounting type (A, B or C). For intermediate temperatures (45°C for example), interpolate between 2 curves.

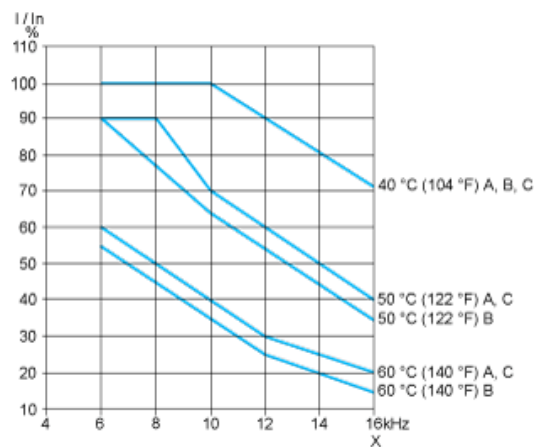

X Switching frequency