

Electrically Compensated Pressure Regulators

Type A4AM, A4AOM, & A2BM
PORT SIZE 3/8"-4" (20MM-100MM)
FOR AMMONIA, R22, R134A, R502
OTHER COMMON REFRIGERANTS

FEATURES

- Unique modular construction
- Suitable for all common refrigerants and oils
- Easy to service
- Interchangeable parts
- 400 psig (27.6 bar) maximum rated pressure (MRP)
- Pilot operated characterized Modulating Plug for precise control
- Manual opening stem
- Close coupled strainers, optional
- Stainless steel diaphragm
- Flanges for threaded or welded steel pipe and copper tube (copper not for ammonia)
- Available in most standard R/S regulator variations (A4AMS, A4ADM, etc...)

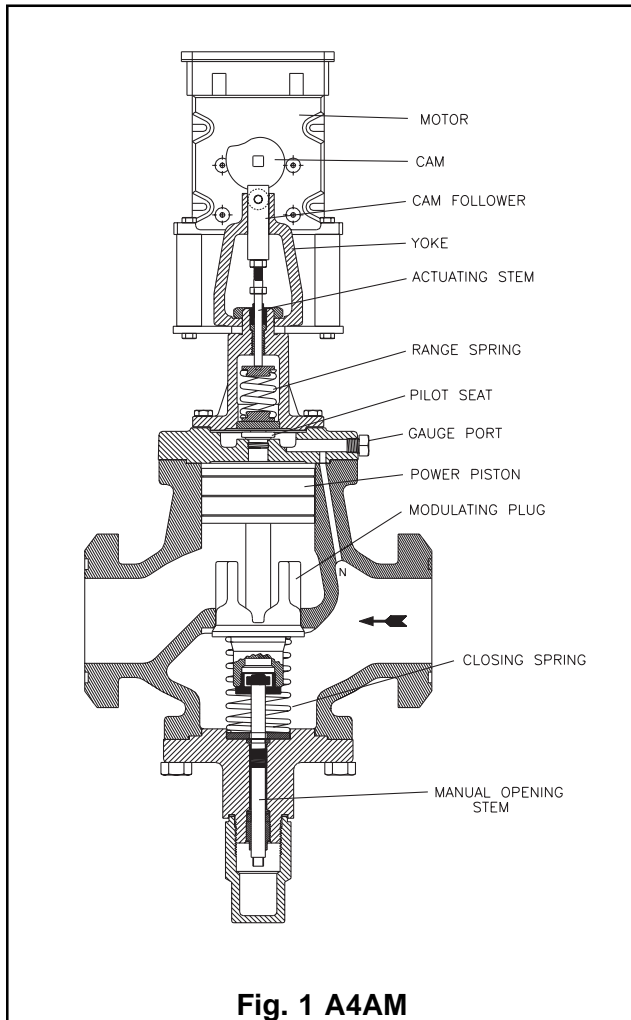

Fig. 1 A4AM

BULLETIN 23-11 Type A4AM



March 2002

Installation, Service and Parts Instruction

DESCRIPTION:

These heavy duty, pilot operated, iron alloy (ASTM A126 Class B) pressure regulators are suitable for R-717, R-22, R-502 and other common refrigerants and fluids approved for use in refrigeration systems. All A4 Regulators are pilot operated using upstream pressure for the opening force and require a minimum 2 psi (0.14 bar) pressure drop to fully open. These valves are generally ordered with a close coupled upstream strainer to prevent the entrance of foreign material into the valve and the rest of the system. The fluid temperature range for the A4 Series of Regulators is -50F to 220F (-45C to 105C).

PURPOSE:

These electrically compensated A4AM inlet pressure regulators modulate the flow of refrigerant gas or liquid to maintain a varying upstream (or inlet) pressure in response to an electrical signal applied to a low voltage motor mounted on a regulator pilot. When supplied with Range D, they also can be used to control condensing pressures; for example, as part of a heat reclaim system.

These regulators are excellent in controlling evaporator pressure/temperature where load fluctuations are great, such as hot carcass chilling, warm fruit and wine chilling and cooling tunnels. They are also useful where product load is fairly constant but very close temperature or humidity control is desired.

When the regulator is used in a location where excessive moisture, corrosion or explosive atmosphere exists, or in low temperature applications where ice could accumulate on the pilot valve stem, the A4AR with A2BM remote pilot can be used. (See Fig. 7)

Important Note:

The motor cover should be kept on the motor at all times to protect it from dust and mechanical damage. No lubrication of the motor is required.

PRINCIPLES OF OPERATION, A4AM (SEE FIG. 1)

The motor will respond to a signal from a suitable controller, for example, a thermostat. When the temperature at the sensing element changes the thermostat, the motor responds immediately to the signal by rotating the motor shaft. This rotation is transmitted through the cam to the valve stem and range spring to change the set-point by changing the spring pressure acting on top of the diaphragm. Whether used as part of a cooling system to control evaporator pressure, or as part of a heat reclaim system to control condensing pressure, an increase in temperature at the thermostat will decrease the spring pressure and lower the inlet pressure thus lowering the evaporator or condenser temperature. Normally cam rotation is 160 degrees and one minute of time is required for the full cam rotation. A motor with 240 degrees and 1.5 minute rotation time is available and must be so ordered.

The principles of operation of the A4AM Series are the same as for the basic A4 regulator except for the varying set-point of the motorized pressure pilot. The inlet refrigerant pressure enters the space under the diaphragm through passage N. When the force created by the inlet pressure exceeds the varying spring force, the diaphragm is lifted off of the pilot seat allowing pressure to enter the top of the power piston. This causes the power piston to move downward forcing the modulating plug to open and modulate to maintain the varying set-point pressure as dictated by the temperature controller signal to the motor. An increase in refrigerant inlet pressure, above the set-point pressure setting, lifts the diaphragm further to allow more pressure on top of the power piston and opens the valve wider. A decrease in inlet pressure, below the varying set-point pressure setting, causes the diaphragm to move closer to the pilot seat reducing the pressure to the top of the piston and causing the closing spring to reduce the valve opening. The pressure on top of the piston is controlled by the flow through the bleed hole in the power piston and through the clearances between the piston and main valve cylinder. A minimum of 2 psi (0.14 bar) pressure drop across the valve is required in order for it to open fully.

ADJUSTMENT A4AM

Adjust the controller sensitivity to the desired point according to the manufacturer's directions. Open the regulator manually (manual opening stem backed out) and run the system until the temperature at the sensing element reaches the desired level. Adjust the controller (thermostat) setting to a reading that will cause the cam of the motor to rotate and stop in center cam position. Put the regulator back into automatic operation by turning the manual opening stem in until just the flats on the stem are visible. Loosen the pressure adjusting screw lock nut and turn the adjusting screw until the desired inlet pressure for this temperature and load condition is reached. Turning the adjusting screw in will lower the pressure; turning it out will raise the pressure. If after several

hours of operation the temperature is not as desired, readjust the pressure adjusting screw slightly. Once the desired setting is reached, make sure the lock nut is tightened. The valve will now modulate in response to load variation to maintain constant temperature.

PRINCIPLES OF OPERATION, A4AOM (SEE FIG. 2)

This pressure regulator modulates the outlet pressure in accordance to load requirements as sensed by an electric thermostat or humidistat that varies an electric signal applied to a motor mounted on the regulator pilot. The motor operation is described above for A4AM, except the A4AOM operates as an outlet pressure regulator. Available in standard Range V or Range D.

The outlet pressure is sensed under the diaphragm through the sensing tube, which is part of the Flange Ring-tube assembly. When the force created by the outlet pressure acting under the diaphragm is less than the force of the range spring, the pilot plug is open, allowing pressure to enter on top of the piston. This causes the power piston to force the throttling plug to open to maintain constant outlet pressure. Decrease in the outlet pressure allows the range spring to open the pilot plug further, allowing more pressure on top of the piston and opening the throttling plug further. An increase in the outlet pressure will lift the diaphragm against the force of the range spring, allowing the pilot plug to start closing. The pressure on top of the power piston is decreased and the closing spring acts to reduce the opening of the throttling plug and the flow of fluid through the regulator. The pressure on top of the power piston is controlled by the flow through the pilot seat and the bleed through a bleed hole in the power piston and through the clearance between the piston and the cylinder. A minimum of 2 psi (0.14 bar) pressure drop across the regulator is required to open it fully.

ADJUSTMENT A4AOM

Adjust the controller sensitivity to the desired point according to the manufacturer's directions. Open the regulator manually (manual opening stem backed out) and run the system until the temperature at the sensing element reaches the desired level. Adjust the controller (thermostat) setting to a reading that will cause the cam of the motor to rotate and stop in center cam position. Put the regulator back into automatic operation by turning the manual opening stem in. Loosen the pressure adjusting screw lock nut and turn the adjusting screw until the desired inlet pressure for this temperature and load condition is reached. Turning the adjusting screw in will lower the pressure; turning it out will raise the pressure. If after several hours of operation the temperature is not as desired, re-adjust the pressure adjusting screw slightly. Once the desired setting is reached, make sure the lock nut is tightened. The valve will now modulate in response to load variation to maintain constant temperature.

MANUAL OPENING STEM:

All Type A4 Regulators are provided with a manual opening stem. To open the regulator manually, back the stem out (turn counter-clockwise) until it stops. To put the regulator into automatic operation, turn the stem in (clockwise) until only the

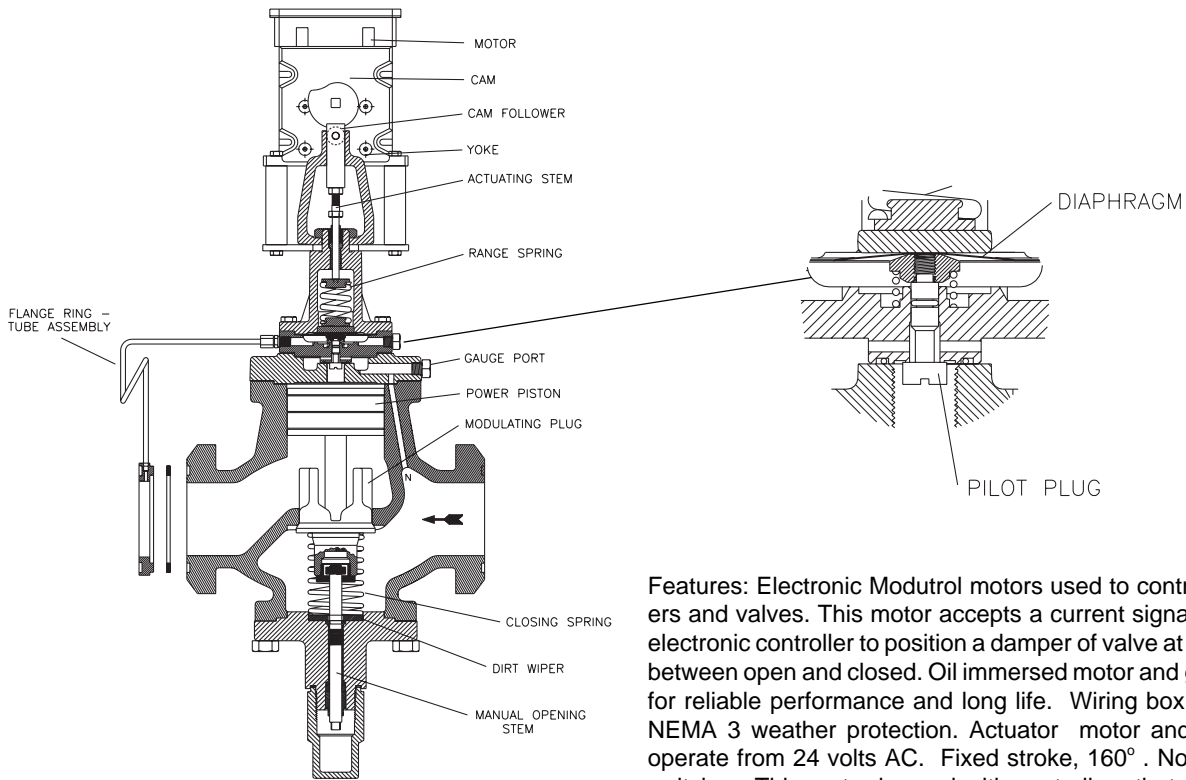

Fig 2. A4AOM

flats on the stem protrude from the packing nut.

OPTIONS

Ranges

Available in Ranges A, V and D. Honeywell motor has 160° cam rotation which is equivalent to a change in set-point of 60 psi (4.1 bar) for Ranges A or V, or 106 psi (7.3 bar) for Range D; Penn motor has 240° cam rotation which changes set-point 90 psi (6.2 bar) for Ranges A or V, or 159 psi (10.9 bar) for Range D.

Motors

Model: M9181A-1012 Honeywell Inc.

Features: Reversing, proportional motors used to operate valves or dampers in electric modulating circuits. Oil immersed motor and gear train for reliable performance and long life. Wiring box provides NEMA 3 weather protection. Actuator motor and circuitry operate from 24 volts AC. Fixed stroke, 160°. No auxiliary switches. The controller type is a 135 ohm Honeywell Series 90 proportional controller (See Fig. 10).

Model: M7284A-1020 Honeywell Inc.

Features: Electronic Modutrol motors used to control dampers and valves. This motor accepts a current signal from an electronic controller to position a damper or valve at any point between open and closed. Oil immersed motor and gear train for reliable performance and long life. Wiring box provides NEMA 3 weather protection. Actuator motor and circuitry operate from 24 volts AC. Fixed stroke, 160°. No auxiliary switches. This motor is used with controllers that provide a stable, noise-free proportional output of 4-20mA nominal, 25mA maximum (See Fig. 13).

Model: M6281A-1009 Honeywell Inc.

Features: Floating control motor with an internal electrically isolated feedback potentiometer. This motor is used with controllers that provide SPDT or floating output to operate dampers or valves. The feedback potentiometer provides an indication of the motors shaft position and can be used for slaving Series 90 motors or rebalancing an external control circuit. Wiring box provides NEMA 3 weather protection. Actuator motor and circuitry operate from 24 volts AC. Fixed stroke, 160°. No auxiliary switches (See Fig. 12).

Model: M6191B-1006 Honeywell Inc.

Features: Non-spring return, 3-wire floating control motor. This motor is used with controllers that provide a switched or floating SPDT output to operate dampers or valves. Actuator motor and circuitry operate from 24 volts AC. Fixed stroke, 160°. One (1), auxiliary switches (See Fig. 14).

Model: M150-JGA-1 Penn Johnson

Features: The M100J motor actuators are used to position valves and dampers in heating ventilating, air conditioning, refrigeration and industrial applications. The motor accepts a Johnson Controls 0 to -2 VDC electronic controller input, or a 0 to +24 VDC input, or a 3-wire 135 to 1000 ohm potentiometer input (See Fig. 11).

A4AM PARTS KITS REFERENCE									
ITEM	DESCRIPTION	PORT SIZE							
		3/4"	1"	1-1/4"	1-5/8"	2"	2-1/2"	3"	4"
12-14, 16	Spring Kit RA,V	202481	202481	202481	202481	202481	202481	202481	202481
	Spring Kit RD	202482	202482	202482	202482	202482	202482	202482	202482
12-17	Conversion Kit A to D	202134	202134	202134	202134	202134	202134	202134	202134
16, 17, 19	Diaphragm Kit RA	200771	200771	200771	200771	200771	200771	200771	200771
16-19	Seat Kit RA	202002	202002	202002	202002	202002	202003	202003	202003
27	Plug Pkg, Pipe	202552	202552	202552	202552	202552	202552	202552	202552
19, 28, 29	Adapter Kit	200703	200703	200700	200725	200725	200685	200713	200716
29, 30	Piston Kit	200760	200760	200767	200389	200389	200391	200393	200227
34-37	Spring Kit, Closing	202300	202300	202301	202302	202302	202303	202304	202305
33-37, 40-42	Plug Kit, Full Capacity	202021	202022	202023	202024	202025	202026	202027	202028
	Plug Kit, 50% Capacity	202029	*	NA	NA	NA	NA	NA	NA
	Plug Kit, 35% Capacity	NA	NA	202031	202032	**	202033	202034	202035
	Plug Kit, 17% Capacity	202030	*	NA	NA	NA	NA	NA	NA
37, 38, 40, 41	Cover Kit	200761	200761	200761	NA	NA	NA	NA	NA
40-42	Packing Kit, Stem	202100	202100	202100	202100	202100	202100	202101	202101
43, 44	Seal Cap Kit	202110	202110	202110	202110	202110	202110	202111	202111
33-38, 40-44	Bottom Kit, Full Capacity	202010	202011	202012	202013	202014	202015	202016	202017
	Bottom Kit, 50% Cap	202347	*	NA	NA	NA	NA	NA	NA
	Bottom Kit, 17% Cap	202346	*	NA	NA	NA	NA	NA	NA
(ALL SEALS)	Gasket/O-Ring Kit	202112	202112	202113	202114	202114	202115	202116	202117
11 (Qty 8)	Bolt Pkg, Bonnet	202246	202246	202246	202246	202246	202246	202246	202246
31 (Qty 8)	Bolt Pkg, Adapter	202248	202248	202248	202248	202248	202248	202248	202248
39 (Qty 6)	Bolt Pkg, Bottom Cap	NA	NA	NA	202251	202251	202251	202252	202252
76	M9181A-1012 (Std)	204141	204141	204141	204141	204141	204141	204141	204141
	M7284A-1020 (4-20 mA)	204142	204142	204142	204142	204142	204142	204142	204142
	M6281A-1009 (Export)	204143	204143	204143	204143	204143	204143	204143	204143
	M6191B-1006	204144	204144	204144	204144	204144	204144	204144	204144
	M150-JGA-1 (Penn)	303421	303421	303421	303421	303421	303421	303421	303421
77, 78	Cam Kit, Standard	202283	202283	202283	202283	202283	202283	202283	202283
	Cam Kit, Low Rise	202135	202135	202135	202135	202135	202135	202135	202135
79, 83	Mounting Post Kit	202426	202426	202426	202426	202426	202426	202426	202426
80-82	Follower Kit, Cam	202118	202118	202118	202118	202118	202118	202118	202118
84, 85	Yoke Kit	202323	202323	202323	202323	202323	202323	202323	202323
86	Plate, Mounting	300772	300772	300772	300772	300772	300772	300772	300772
87-90	Stem Kit, Actuating	202119	202119	202119	202119	202119	202119	202119	202119
(*) Use capacity reduction kit for 3/4" port regulator									
(**)Use capacity reduction kit for 1-5/8" port regulator									

OTHER CONFIGURATIONS

A4AMS

Description

The Type A4AMS is an electrically compensated inlet pressure regulator with a pilot electric shut-off. The integrally mounted solenoid must be energized for the valve to function as a regulator. When de-energized, the regulator is closed, regardless of inlet pressure.

Purpose

The Type A4AMS should be used whenever it is required to stop all flow (in the normal fluid flow direction) through the regulator. This could include use in defrost applications and as part of a temperature control system.

PRINCIPLES OF OPERATION, A4AMS

The operation of the A4AMS is the same as that described on Page 2, except the inlet pressure from passage N must first pass through the S6A pilot solenoid before it can reach the

diaphragm. Thus, the S6A pilot solenoid must be energized before the A4AMS can begin to regulate, regardless of inlet pressure (See also Bulletin 23-06).

Adjustment, A4AMS

With the solenoid pilot energized, proceed as described under Adjustment A4AM.

A4ABM

Description

The Type A4ABM is an inlet pressure regulator with a pilot electric wide opening feature. When the integrally mounted solenoid is energized, the valve is wide open, thereby bypassing the regulator function; i.e., not regulating. However, in the wide open mode the regulator will still require the 2 psi (0.14 bar) minimum pressure drop. When the solenoid is de-energized, the valve functions as an electrically compensated inlet pressure regulator.

Item	Description
8	Bonnet
9	Nameplate
10	Screw , Nameplate
11	Screw , Bonnet
12	Spring Rest, Upper
13	Spring, Range
14	Spring Rest, Low er
15	Diaphragm Follow er
16	Gasket, Bonnet
17	Diaphragm
18	Seat, Pilot
19	Gasket, Adapter
27	Gauge Port Pipe Plug
28	Adapter, Body
29	Gasket, Body
30	Piston-Stem
31	Screw , Body
32	Body
33	Throttling Plug Asm
34	Spring, Closing
35	Dirt Wiper Retainer
36	Dirt Wiper
37	Seal, Bottom Cap
38	Bottom Cap
39	Screw , Bottom Cap
40	Packing Washer
41	Packing Ring
42	Stuffing Box Nut
43	Gasket, Seal Cap
44	Seal Cap
45	Gasket, Flange
46	Bolt, Flange
47	Nut, Flange
76	Motor
77	Cam Lock Screw
78	Motor Cam
79	Motor Mounting Screw
80	Cam Follow er Asm
81	Lock Nut
82	Pressure Adjusting Screw
83	Mounting Post
84	Guide Post
85	Guide Post Locknut
86	Mounting Plate
87	Actuating Stem
88	Stuffing Box Nut
89	Packing Ring
90	Stem Insert

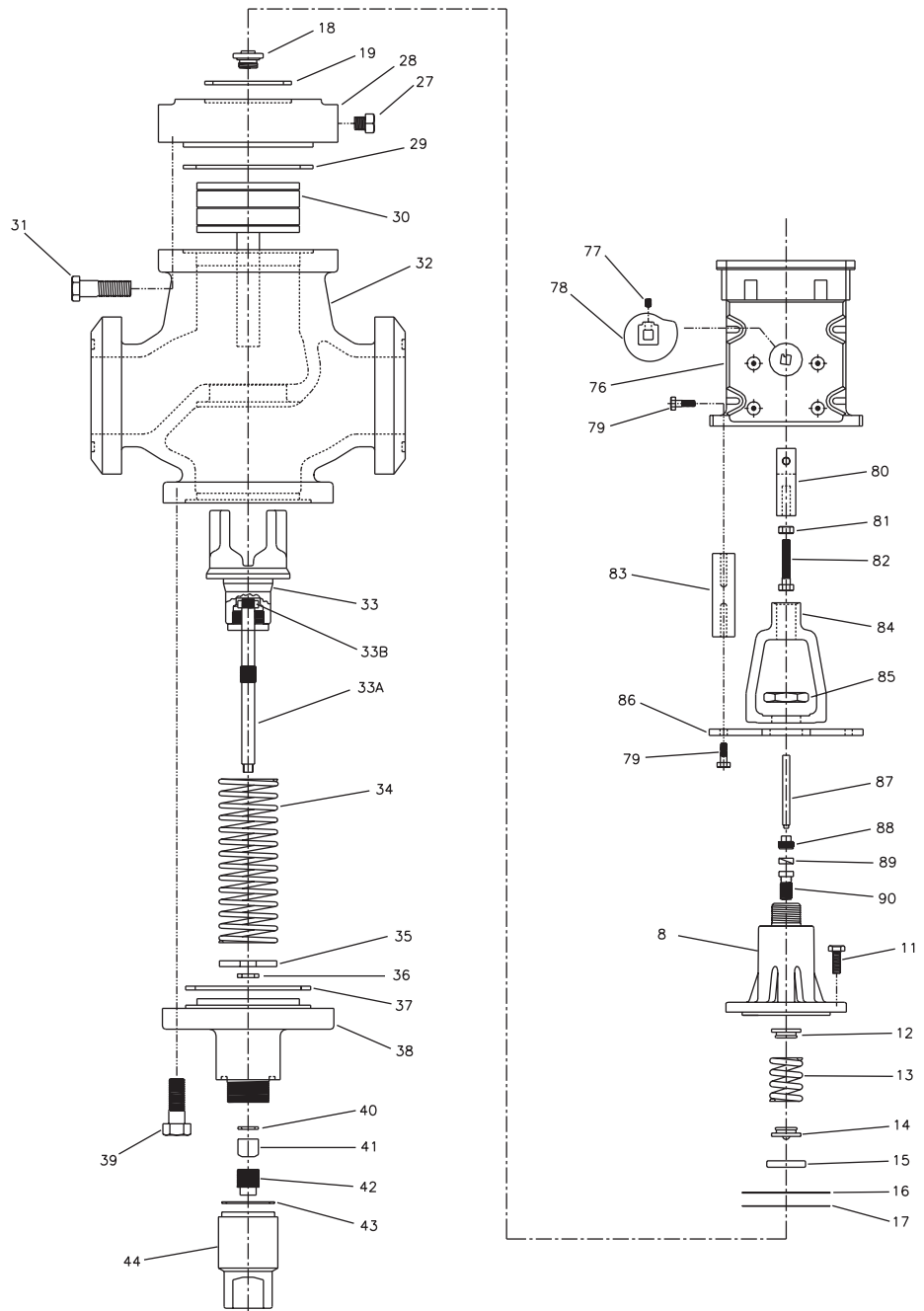

Fig. 3 A4AM

		A4AOM PARTS KITS REFERENCE							
						PORT SIZE			
ITEM	DESCRIPTION	3/4"	1"	1-1/4"	1-5/8"	2"	2-1/2"	3"	4"
12-14, 16	Spring Kit RA,V	202481	202481	202481	202481	202481	202481	202481	202481
	Spring Kit RD	202482	202482	202482	202482	202482	202482	202482	202482
12-17	Conversion Kit A to D	202134	202134	202134	202134	202134	202134	202134	202134
16, 17, 19	Diaphragm Kit RA	200771	200771	200771	200771	200771	200771	200771	200771
19, 22-26	Plug Kit	200777	200777	200777	200777	200777	200778	200778	200778
19, 21-26	Outlet Regulator Kit	200516	200516	200516	200516	200516	200517	200517	200517
20, 45	Ring-Tube Kit	200439	200439	200441	200443	200443	200445	200447	200449
27	Plug Pkg, Pipe	202552	202552	202552	202552	202552	202552	202552	202552
19, 28, 29	Adapter Kit	200703	200703	200700	200725	200725	200685	200713	200716
29, 30	Piston Kit	200760	200760	200767	200389	200389	200391	200393	200227
34-37	Spring Kit, Closing	202300	202300	202301	202302	202302	202303	202304	202305
33-37, 40-42	Plug Kit, Full Capacity	202021	202022	202023	202024	202025	202026	202027	202028
	Plug Kit, 50% Capacity	202029	*	NA	NA	NA	NA	NA	NA
	Plug Kit, 35% Capacity	NA	NA	202031	202032	**	202033	202034	202035
	Plug Kit, 17% Capacity	202030	*	NA	NA	NA	NA	NA	NA
37, 38, 40, 41	Cover Kit	200761	200761	200761	NA	NA	NA	NA	NA
40-42	Packing Kit, Stem	202100	202100	202100	202100	202100	202100	202101	202101
43, 44	Seal Cap Kit	202110	202110	202110	202110	202110	202110	202111	202111
33-38, 40-44	Bottom Kit, Full Capacity	202010	202011	202012	202013	202014	202015	202016	202017
	Bottom Kit, 50% Cap	202347	*	NA	NA	NA	NA	NA	NA
	Bottom Kit, 17% Cap	202346	*	NA	NA	NA	NA	NA	NA
(ALL SEALS)	Gasket/O-Ring Kit	202112	202112	202113	202114	202114	202115	202116	202117
11 (Qty 8)	Bolt Pkg, Bonnet	202247	202247	202247	202247	202247	202247	202247	202247
31 (Qty 8)	Bolt Pkg, Adapter	202248	202248	202248	202248	202248	202248	202248	202248
39 (Qty 6)	Bolt Pkg, Bottom Cap	NA	NA	NA	202251	202251	202251	202252	202252
76	M9181A-1012 (Std)	204141	204141	204141	204141	204141	204141	204141	204141
	M7284A-1020 (4-20 mA)	204142	204142	204142	204142	204142	204142	204142	204142
	M6281A-1009 (Export)	204143	204143	204143	204143	204143	204143	204143	204143
	M6191B-1006	204144	204144	204144	204144	204144	204144	204144	204144
	M150-JGA-1 (Penn)	303421	303421	303421	303421	303421	303421	303421	303421
77, 78	Cam Kit, Standard	202283	202283	202283	202283	202283	202283	202283	202283
	Cam Kit, Low Rise	202135	202135	202135	202135	202135	202135	202135	202135
79, 83	Mounting Post Kit	202426	202426	202426	202426	202426	202426	202426	202426
80-82	Follower Kit, Cam	202118	202118	202118	202118	202118	202118	202118	202118
84, 85	Yoke Kit	202323	202323	202323	202323	202323	202323	202323	202323
86	Plate, Mounting	300772	300772	300772	300772	300772	300772	300772	300772
87-90	Stem Kit, Actuating	202119	202119	202119	202119	202119	202119	202119	202119
	(*) Use capacity reduction kit for 3/4" port regulator								
	(**) Use capacity reduction kit for 1-5/8" port regulator								

Purpose

The Type A4ABM frequently is used with the wide open function, where maximum refrigeration capacity from the evaporator is required for some period of time. With the solenoid de-energized, the regulator is electrically compensated.

Principle of Operation A4ABM

The operation of the A4ABM is the same as that described on Page 2 when operating as a regulator (pilot solenoid de-energized). When the solenoid is energized the upstream pressure from passage N bypasses the underside of the diaphragm and is fed directly to the top of the piston where, provided a 2 psi (0.14 bar) pressure difference exists across the main valve throttling plug will be held open (See also Bulletin 23-06).

Adjustment, A4ABM

With the solenoid pilot electrically de-energized, proceed as

described under Adjustment A4AM.

A4ADM

Description

The Type A4ADM is a Dual Inlet Pressure Regulator capable of regulating at two (2) pressure levels, one a fixed set-point and the other being the electrically compensated set-point. When the integrally mounted S6A pilot solenoid valve is energized, the regulator is controlling at the lower of two set-points. This would be the electrically compensated low pressure pilot doing the controlling. When the pilot solenoid is de-energized the regulator is controlling at the higher set-point, which must be adjusted on the bolt-on (outboard) pressure pilot.

Note: The high pressure pilot must always be set higher than what the electrically compensated pilot can reach in order to prevent the high pressure pilot from controlling when not

Item	Description
8	Bonnet
9	Nameplate
10	Screw , Nameplate
11	Screw , Bonnet
12	Spring Rest, Upper
13	Spring, Range
14	Spring Rest, Lower
15	Diaphragm Follow er
16	Gasket, Bonnet
17	Diaphragm
19	Gasket, Adapter
20	Flg Ring-tube Asm
21	Adapter, A4AO
22	Spring Nut
23	Spring, Pilot Plug
24	Pilot Plug
25	O-Ring Seal
26	O-Ring, Pilot Plug
27	Gauge Port Pipe Plug
28	Adapter, Body
29	Gasket, Body
30	Piston-Stem
31	Screw , Body
32	Body
33	Throttling Plug Asm
34	Spring, Closing
35	Dirt Wiper Retainer
36	Dirt Wiper
37	Seal, Bottom Cap
38	Bottom Cap
39	Screw , Bottom Cap
40	Packing Washer
41	Packing Ring
42	Stuffing Box Nut
43	Gasket, Seal Cap
44	Seal Cap
45	Gasket, Flange
46	Bolt, Flange
47	Nut, Flange
76	Motor
77	Cam Lock Screw
78	Motor Cam
79	Motor Mounting Screw
80	Cam Follow er Asm
81	Lock Nut
82	Pressure Adjusting Screw
83	Mounting Post
84	Guide Post
85	Guide Post Locknut
86	Mounting Plate
87	Actuating Stem
88	Stuffing Box Nut
89	Packing Ring
90	Stem Insert

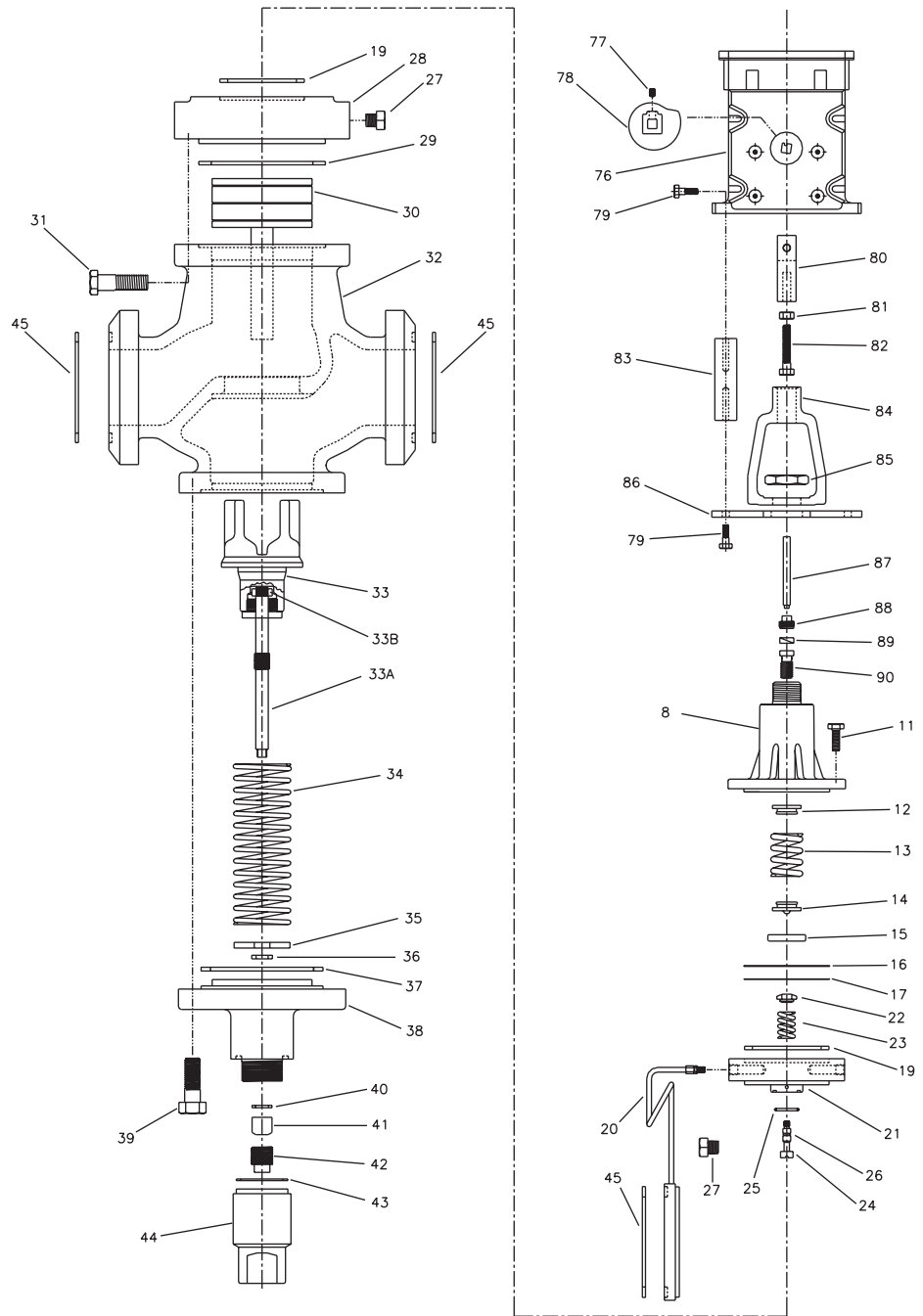

Fig. 4 A4AOM

A2_M PARTS KITS REFERENCE				
		A2B2M	A2BM	A2AM
ITEM	DESCRIPTION			
12-14, 16	Spring Kit RA,V	202481	202481	202481
	Spring Kit RD	202482	202482	202482
12-17	Conversion Kit A to D	202134	202134	202134
16, 17, 19	Diaphragm Kit RA	200771	200771	200771
16-19	Seat Kit RA	202002	202003	202005
11 (Qty 8)	Bolt Pkg, Bonnet	202246	202246	202246
21 (Qty 5)	Plug Pkg	202552	202552	202552
76	M9181A-1012 (Std)	204141	204141	204141
	M7284A-1020 (4-20 mA)	204142	204142	204142
	M6281A-1009 (Export)	204143	204143	204143
	M6191B-1006	204144	204144	204144
	M150-JGA-1 (Penn)	303421	303421	303421
77, 78	Cam Kit, Standard	202283	202283	202283
	Cam Kit, Low Rise	202135	202135	202135
79, 83	Mounting Post Kit	202426	202426	202426
80-82	Follower Kit, Cam	202118	202118	202118
84, 85	Yoke Kit	202323	202323	202323
86	Plate, Mounting	300772	300772	300772
87-90	Stem Kit, Actuating	202119	202119	202119

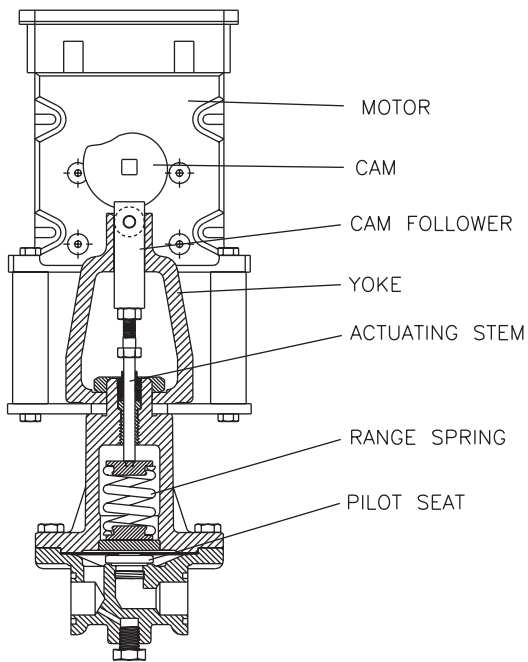
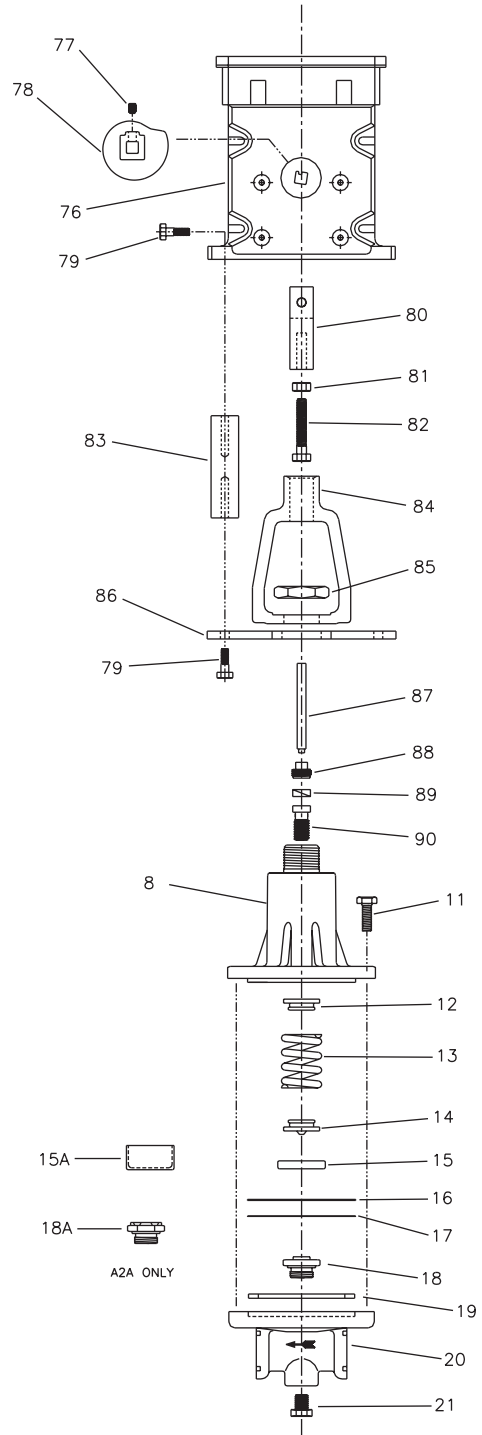

Fig. 5 A2BM

BOLT TORQUE TABLE		
ITEM	PORT SIZE	TORQUE
7/16" Flange Bolt	1/2"	28 ft lb
5/8" Flange Bolt	3/4" - 2"	85 ft lb
3/4" Flange Bolt	2-1/2" - 3"	105 ft lb
7/8" Flange Bolt	4"	150 ft lb
5/16"-18 Bonnet Bolt	3/4" - 4"	11 ft lb
5/16"-18 Adapter Bolt	3/4" - 2"	11 ft lb
5/8"-11 Adapter Bolt	3" - 4"	75 ft lb
Bottom Cap	3/4"- 1-1/4"	150 ft lb
1/2"-13 Bottom Cap Bolt	1-5/8" - 2-1/2"	50 ft lb
5/8"-11 Bottom Cap Bolt	3"-4"	75 ft lb

Item	Description
8	Bonnet
9	Nameplate
10	Screw , Nameplate
11	Screw , Bonnet
12	Spring Rest, Upper
13	Spring, Range
14	Spring Rest, Low er
15	Diaphragm Follow er
16	Gasket, Bonnet
17	Diaphragm
18	Seat, Pilot
19	Gasket, Adapter
20	Valve Body
21	Plug
76	Motor
77	Cam Lock Screw
78	Motor Cam
79	Motor Mounting Screw
80	Cam Follow er Asm
81	Lock Nut
82	Pressure Adjusting Screw
83	Mounting Post
84	Guide Post
85	Guide Post Locknut
86	Mounting Plate
87	Actuating Stem
88	Stuffing Box Nut
89	Packing Ring
90	Stem Insert



A2AM A2BM

Fig. 6

required.

Purpose

The Type A4ADM uses are similar to those for the A4ABM except, instead of operating in a wide open position when the pilot solenoid is energized, the regulator is controlling the inlet pressure through the motorized pressure pilot in response to an electric signal from its controller.

Typical uses include capacity control of an evaporator at different pressure levels to regulate temperature at varying load conditions (Low pressure compensating pilot), and evaporator pressure control combined with defrost pressure relief (high pressure pilot).

Principles of Operation, A4ADM

The operation of the A4ADM is similar to that described on Page 2. When the Pilot Solenoid is energized, upstream pressure from passage N is made available to both pressure pilot diaphragms. Since the path of least resistance will be through the pressure pilot with the lower set-point (lower range spring force), that pilot will control.

When the pilot solenoid is de-energized, upstream pressure from passage N can flow only to the higher pressure pilot, which will then control the regulator (See also Bulletin 23-06).

Adjustment A4ADM

Electrically de-energize the solenoid pilot and adjust the modular (bolt on) pressure pilot for the desired high pressure setting. Remove the seal cap on top of the high pressure pilot (outboard pilot) and turn the adjusting stem clockwise to increase setting or counter clockwise to decrease setting. Final adjustment should be made after the system has been operating for a period of time. Electrically energize the pilot solenoid and adjust the motorized pressure pilot (low pressure) as described under Adjustment A4AM.

A2BM

Principles of Operation, A2BM (See Fig. 5)

The A2 type pressure regulators are compact, direct diaphragm operated, for use with refrigerant liquid or vapor. The A2BM and A2AM are inlet pressure regulators that prevent

inlet (or upstream) pressure from falling below set-point. They will tend to open on a rise in inlet pressure above set-point and will be closed below set-point. The pressure regulator will have a varying set point in accordance to load requirements as sensed by an electric thermostat or humidistat that varies an electric signal to a motor mounted on the regulator bonnet. The motor operation is as described on Page 2 for A4AM.

The inlet pressure acts on the diaphragm. When the force created by the pressure exceeds the force of the range spring, the diaphragm is lifted off of the valve seat and flow occurs through the valve seat, from the regulator inlet to the outlet. Increased inlet pressure lifts the diaphragm further, allowing increased flow. Decrease in inlet pressure causes the diaphragm to move closer to the valve seat, reducing the flow. Thus, the regulator acts to maintain the inlet pressure approximately constant. If the inlet pressure drops below the regulator setting, the diaphragm closes off the flow to keep the inlet pressure from going below the set point, subject to limits of seat leakage tolerance, or leakage due to dirt particles on the seat surfaces.

Adjustment, A2BM

Adjust the controller sensitivity to the desired point according to the manufacturer's directions. Loosen the pressure adjusting screw lock nut and adjust pressure screw until disengaged with the valve actuating stem. Run the system until the temperature at the sensing element reaches the desired level. Adjust the controller (thermostat) setting to a reading that will cause the cam of the motor to rotate and stop in center cam position. Turn the adjusting screw to engage the valve actuating stem, and adjust until the desired inlet pressure for this temperature and load condition is reached. Turning the adjusting screw in will lower the pressure; turning it out will raise the pressure. If after several hours of operation the temperature is not as desired, readjust the pressure adjusting screw slightly. Once the desired setting is reached, make sure the lock nut is tightened. The valve will now regulate in response to load variation to maintain constant temperature.

Installation

All regulators are packed for maximum protection. Unpack carefully. Check the carton to make sure all flanges and other items are unpacked. Save the enclosed instructions for the installer and eventual user.

Do not remove the protective coverings from the inlet and outlet of the regulator until the regulator is ready to be installed. Protect the inside of the regulator from moisture, dirt and chips before and during installation. When welded or brazed flange connections are used, all slag, scale and loose particles should be removed from the flange interior before the regulator is installed between the flanges. It is advisable to install a close-coupled companion strainer (RSF) at the inlet of the regulator to help protect it from any foreign material in the system.

The A4 series of regulators will give optimum performance if mounted in a horizontal line in a vertical position with the manual opening stem on bottom. Where other positions are

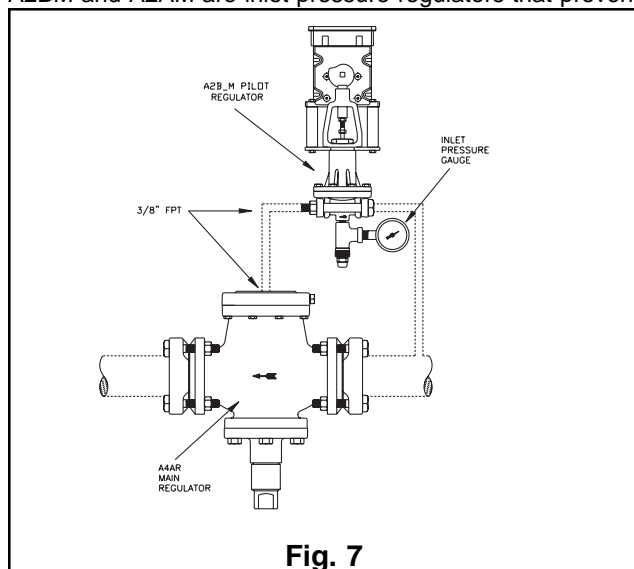

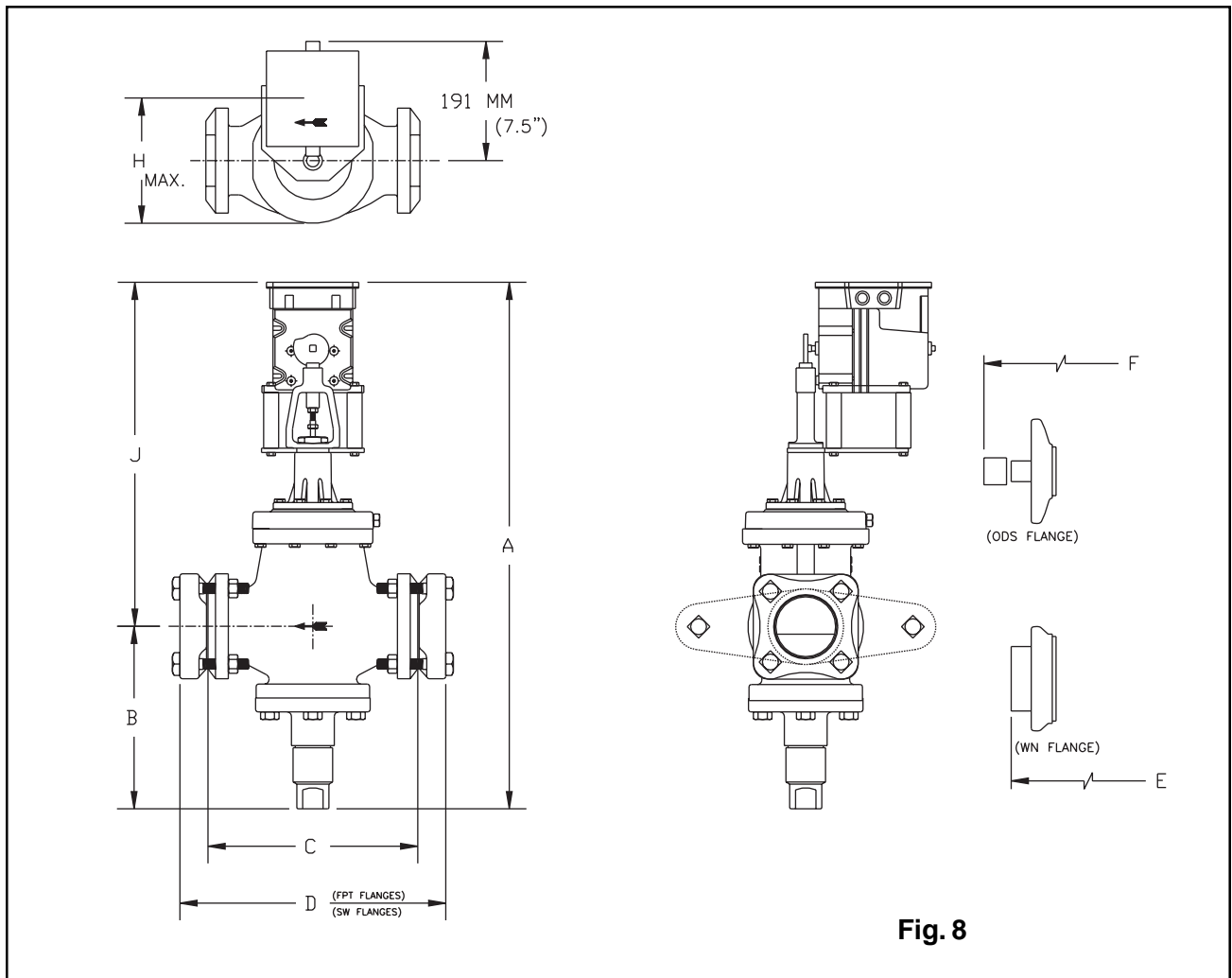
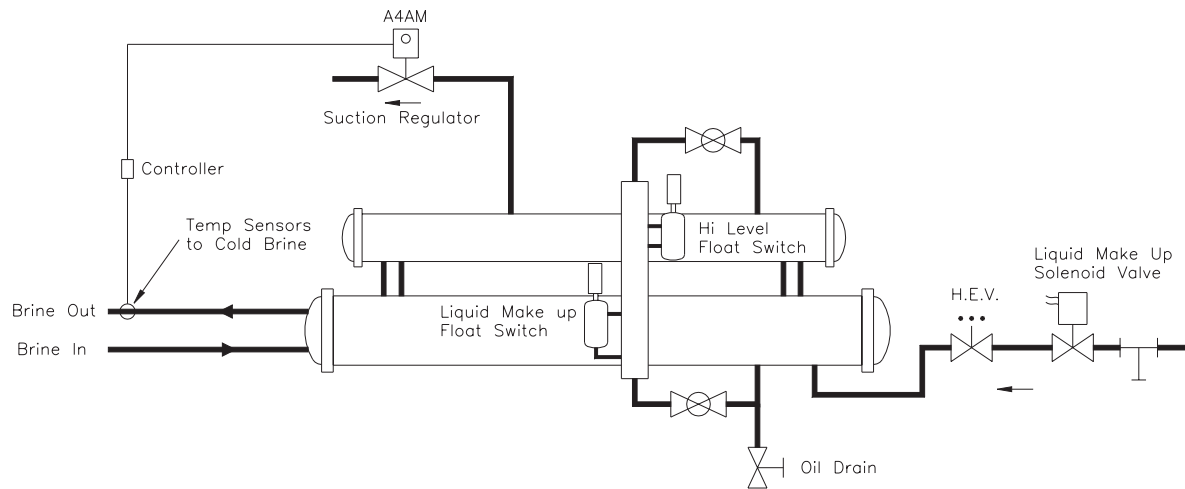

Fig. 8

		A4AM OVERALL VALVE DIMENSIONS											
PORT SIZE		3/4" & 1"		1-1/4"		1-5/8" & 2"		2-1/2"		3"		4"	
		(20 & 25 MM)		(32 MM)		(40 & 50 MM)		65 MM		75 MM		100 MM	
DIMENSION		MM	INCH	MM	INCH	MM	INCH	MM	INCH	MM	INCH	MM	INCH
A	A4AM	597	23.5	615	24.2	668	26.3	688	27.1	803	31.6	859	33.8
A	A4AOM	620	22.4	638	23.1	691	25.2	711	26.0	826	32.5	882	34.7
B	(ALL TYPES)	148	5.8	162	6.3	177	6.9	181	7.1	273	10.7	292	11.5
C	(ALL TYPES)	164	6.2	203	8.0	251	9.9	252	9.9	311	12.2	359	14.1
G	(ALL TYPES)	98	3.9	178	7.0	251	9.9	314	12.4	314	12.4	363	14.3
H	(ALL TYPES)	117	4.6	117	4.6	140	5.5	159	6.2	176	7.0	222	8.8
J	A4AM	449	17.7	453	17.9	491	19.4	507	20.0	530	20.9	566	22.3
J	A4AOM	472	18.6	476	18.8	514	20.3	530	20.9	553	21.8	589	23.2

		OVERALL LENGTH DIMENSIONS WITH FLANGES																		
PORT SIZE		3/4" & 1"				1-1/4"				1-5/8" & 2"				2-1/2"		3"		4"		
		(20 & 25 MM)				(32 MM)				(40 & 50 MM)				65 MM		75 MM		100 MM		
DIMENSION		PIPE SIZE	MM	INCH	PIPE SIZE	MM	INCH	PIPE SIZE	MM	INCH	PIPE SIZE	MM	INCH	PIPE SIZE	MM	INCH	PIPE SIZE	MM	INCH	
D	FPT & SW	1/2"	216	8.5	1-1/4"	256	10.1	1-1/2"	307	12.1	2-1/2"	331	13.0	3"	389	15.3	3-1/2"	450	17.7	
	FOR PIPE	3/4"	216	8.5	1-1/2"	256	10.1	2"	256	12.1							4"	450	17.7	
	SIZES	1"	216	8.5																
	SHOWN	1-1/4"	216	8.5																
E	WN FOR	3/4"	254	10.0	1-1/4"	300	11.8	1-1/2"	364	14.3	2-1/2"	401	15.8	3"	478	18.8	4"	571	22.5	
	PIPE SIZES	1"	261	10.3	1-1/2"	304	12.0	2"	371	14.6										
	SHOWN	1-1/4"	261	10.3																
F	ODS FOR	7/8"	239	9.4	1-3/8"	269	10.6	1-5/8"	358	14.1	2-5/8"	348	13.7	3-1/8"	414	16.3	4-1/8"	503	19.8	
	TUBE SIZES	1-1/8"	239	9.4	1-5/8"	279	11.0	2-1/8"	338	13.3	3-1/8"	389	15.3	3-5/8"	432	17.0				
	SHOWN	1-3/8"	231	9.1	2-1/8"	305	12.0	2-5/8"	358	14.1										
		1-5/8"	239	9.4																
N	ODS TUBE	7/8"	19	0.8	1-3/8"	25	1.0	1-5/8"	28	1.1	2-5/8"	38	1.5	3-1/8"	43	1.7	4-1/8"	55	2.2	
	ENGAGE-	1-1/8"	23	0.9	1-5/8"	28	1.1	2-1/8"	33	1.3	3-1/8"	43	1.7	3-5/8"	48	1.9				
	MENT	1-3/8"	25	1.0	2-1/8"	33	1.3	2-5/8"	38	1.5										
		1-5/8"	28	1.1																
P	SW PIPE	1/2"	13	0.5	1-1/4"	15	0.6	1-1/2"	15	0.6	2-1/2"	25	1.0	3"	29	1.1	3-1/2"	32	1.3	
	ENGAGE-	3/4"	13	0.5	1-1/2"	15	0.6	2"	15	0.6							4"	32	1.3	
	MENT	1"	13	0.5																
		1-1/4"	18	0.7																

TYPICAL APPLICATION



Flooded Chiller With Surge Drum

Fig. 9

desired, the factory should be consulted: please give application and piping details. To function properly, the regulator must be installed with the arrow on the valve body pointing in the direction of the fluid flow. Backward flow through the regulator is uncontrolled and will vary with valve model and the reverse pressure drop encountered.

Tighten the flange bolts and nuts evenly to provide proper seating of the flange gasket and to avoid damage to gaskets or flanges (See Flange Bolt Torque Table). Avoid using the regulator flange bolts to stretch or align pipe. Even the heavy body of an A4 can be distorted, causing the precision parts to bind.

The regulator should be installed in a location where it is easily accessible for adjustment and maintenance. The location should be such that the regulator cannot be easily damaged by material handling equipment. When it is necessary to insulate the regulator (and companion strainer), the insulation should be installed to provide access to the regulator (and companion strainer) for adjustment and maintenance. Do not insulate the solenoid coil and coil housing. Proper indicating gauges should be installed to be easily visible to the operating engineer for system checking and adjusting purposes.

Maintenance and Service

General Procedure:

Dirt in the system is the greatest single cause of regulator malfunction. All screens or filters should be cleaned or replaced when they become dirty. At start-up, it is especially important that these items are cleaned or changed frequently. When the RSF close-coupled companion strainer

is used, maintain according to instruction in Bulletin 00-10. Moisture in halocarbon systems in particular, can cause corrosion or form ice, causing the piston to freeze in position. Filter-driers should be used and maintained for halocarbon systems.

Before deciding to disassemble a regulator for servicing, the following investigations should be made:

Check the manual opening stem; it should be turned in for automatic operation.

Check the cam and cam follower alignment. There should be clearance between the cam and follower on both sides.

Check for smooth actuating stem movement with cam rotation. The packing nut should be tight enough to prevent moisture penetration and loose enough to permit smooth stem stroking.

Check regulator pressure range; if wrong, range spring must be replaced.

Check other system components for proper operation.

Check hand valves in the system to make sure they are open or closed as required and the system is receiving liquid or gas, as the case may be.

Before disassembly of regulator, make certain that all refrigerant has been removed (pumped out) from the regulator and its companion strainer where one is used.

Read Safety Bulletin RSB.

Safe Operation (See also Bulletin RSBCV)

People doing any work on a refrigeration system must be qualified and completely familiar with the system and the Refrigerating Specialties Division valves involved, or all other precautions will be meaningless. This includes reading and understanding pertinent Refrigerating Specialties Division product bulletins and Safety Bulletin RSB prior to installation or servicing work.

Where cold refrigerant liquid lines are used, it is necessary that certain precautions be taken to avoid damage that could result from liquid expansion. Temperature increase in a piping section full of solid liquid will cause high pressure, due to the expanding liquid that can possibly rupture a gasket, pipe or valve. All hand valves isolating such sections should be marked, warning against accidental closing, and must not be closed until the liquid is removed. Check valves must never be installed upstream of solenoid valves or regulators with electric shut-off, nor should hand valve upstream of solenoid valves or downstream of check valves be closed until the liquid has been removed. It is advisable to properly install relief devices in any section where liquid expansion could take place.

Avoid all piping or control arrangements that might produce thermal or pressure shock. For the protection of people and products, all refrigerant must be removed from the section to be worked on before a valve, strainer, or other device is opened or removed. Flanges with ODS connections are not suitable for ammonia service.

Warranty

All Refrigerating Specialties products are warranted against defects in workmanship and materials for a period of one (1) year from date of shipment from originating factory. This warranty is in force only when products are properly installed, field assembled, maintained, and operated in use and service as specifically stated in Refrigerating Specialties catalogs or bulletins for normal refrigeration applications, unless otherwise approved in writing by Refrigerating Specialties Division. Defective products or parts returned to the factory with transportation charges prepaid and found to be defective by factory inspection will be replaced or repaired at Refrigerating Specialties option, free of charge F.O.B. factory. Warranty does not cover products that have been altered or repaired in the field, damaged in transit as a result of accidents, misuse, or abuse. Products disabled by dirt or other foreign substances will not be considered defective. The express warranty above constitutes the only warranty of Refrigerating Specialties products and is in lieu of all other warranties, expressed or implied, written or oral, including any warranty of merchantability or warranty of fitness for a particular purpose. In no event is Refrigerating Specialties responsible for any consequential damages of any nature whatsoever. No employee, agent, dealer or other person is authorized to give any warranties on behalf of Refrigerating Specialties nor to assume for Refrigerating Specialties any other liability in connection with any of its products.

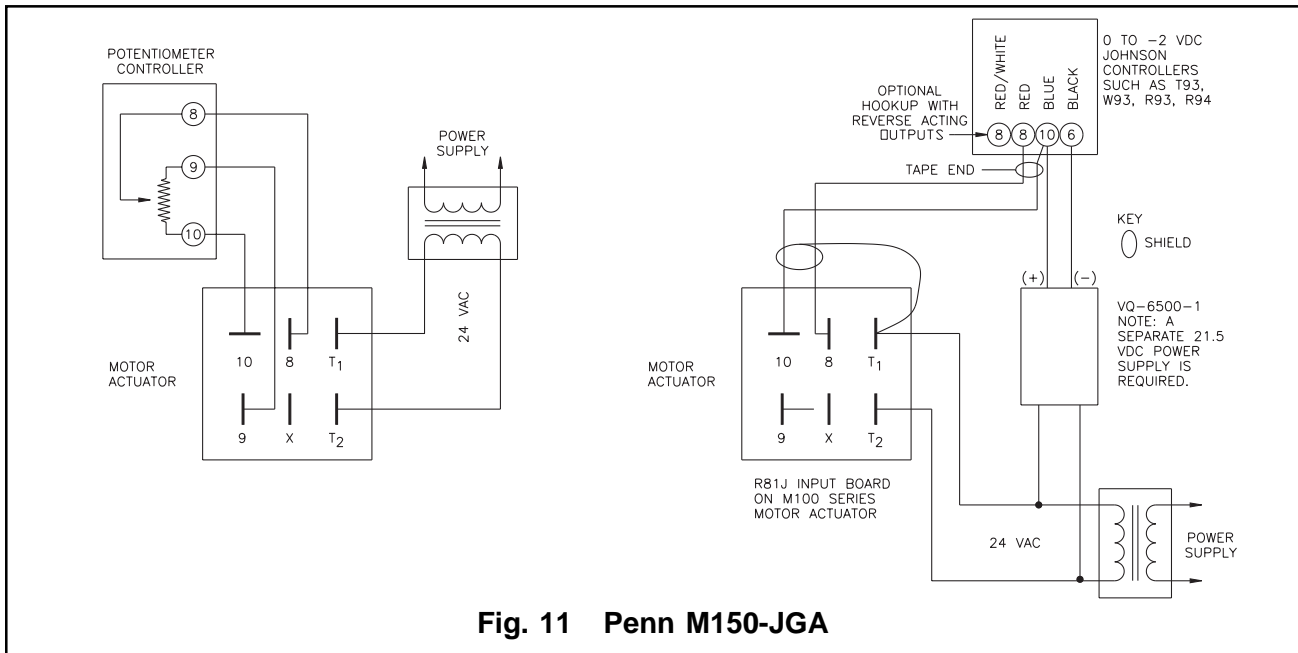
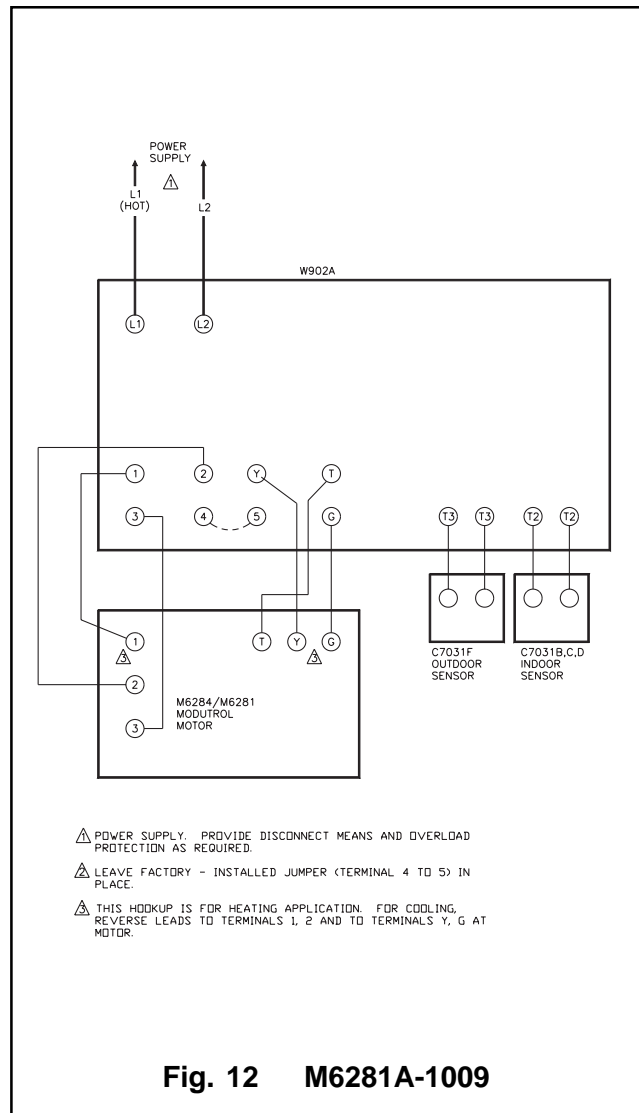
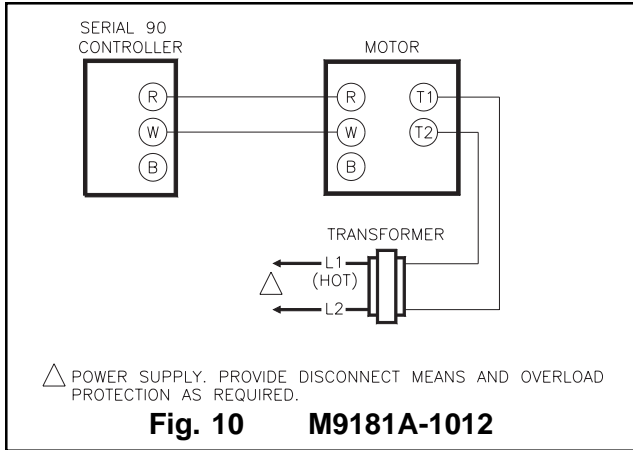

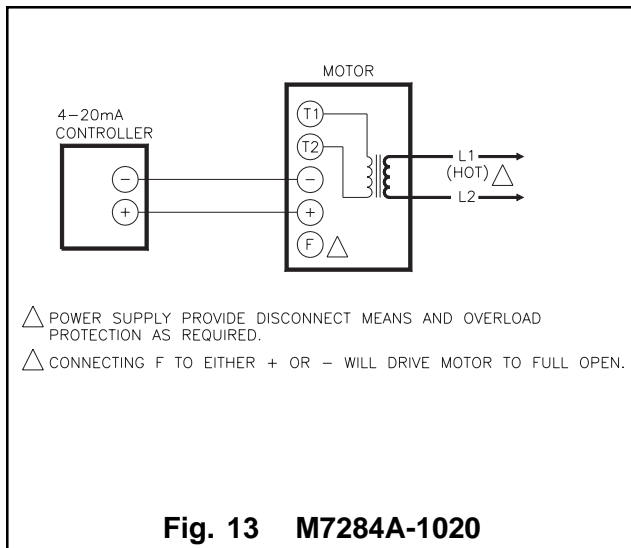

Fig. 13 M7284A-1020

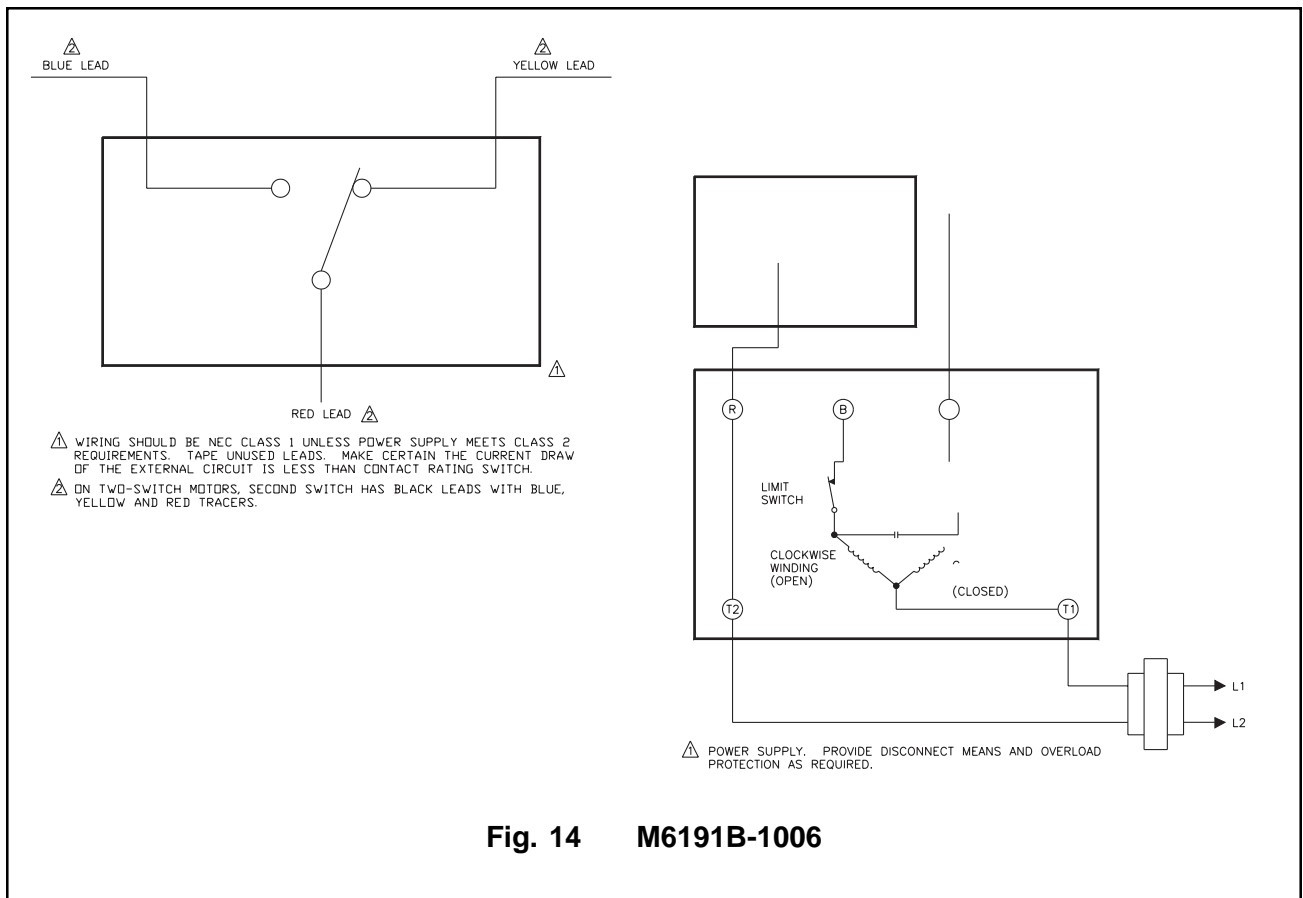

Fig. 14 M6191B-1006

