

# ADAPTOMODE® INLET PRESSURE REGULATORS

Types: A4AS, A4AB, A4AD, A4AZ

PORT SIZE 20 - 100 mm (3/4" - 4")  
FOR AMMONIA, R-12, R-22, R-502  
OTHER REFRIGERANTS AND OIL

## FEATURES

- Pilot operated characterized Modulating Plug for precise control
- Suitable for all common refrigerants and oil
- 28 bar (400 psig) maximum rated pressure (MRP)
- Flanges for threaded or welded steel pipe and copper tube (copper not for ammonia)
- Unique Modular construction
- Interchangeable parts
- Easy to service
- Close coupled strainers, optional
- Many control variations are possible with the use of a few Modules and kits.
- Stainless Steel Diaphragm
- Chrome Plated Pilot Seat
- Manual Opening Stem

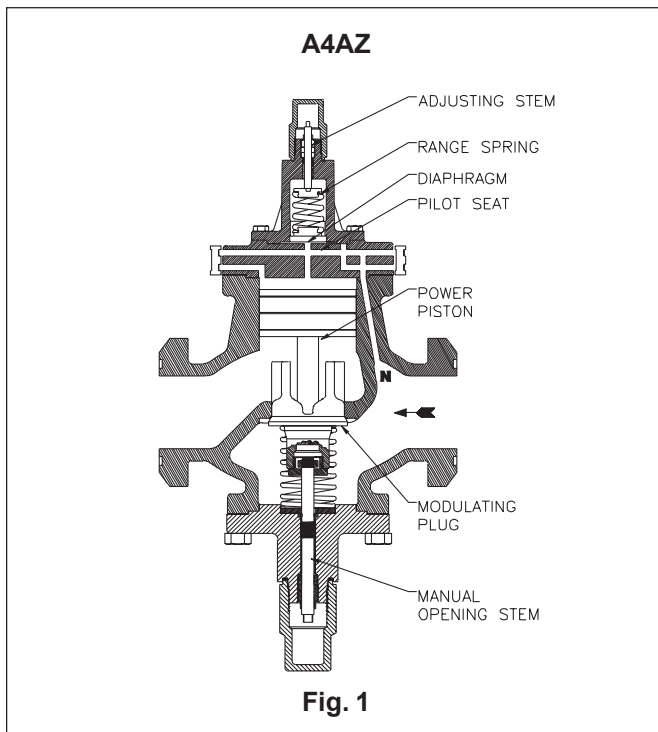

## Description:

These compact, heavy duty, pilot operated, iron alloy (ASTM A126 Class B high strength semi-steel) Inlet Pressure Regulators are suitable for Ammonia, R-12, R-22, R-502 and other common refrigerants and fluids approved for use in refrigeration systems.

All A4 Regulators are pilot operated using upstream pressure for the opening force and require a minimum 0.14 bar (2 psi) pressure drop to fully open.

These valves are generally ordered with close coupled upstream strainer to prevent entrance of foreign material into the valve and the rest of the system. (See current Bul. 00-10 for strainer information.)

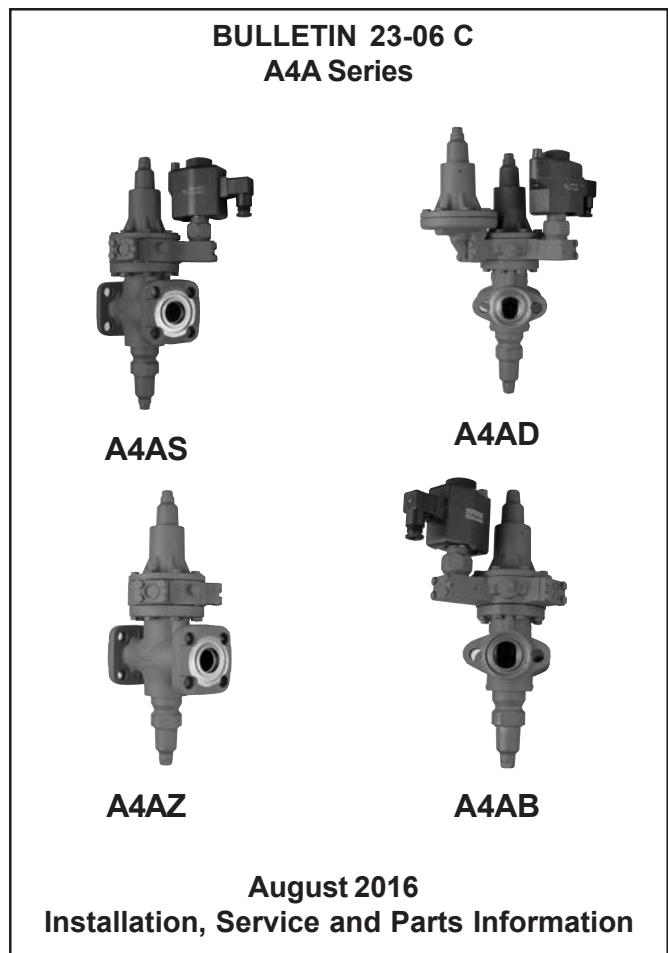

## Purpose

Modulates flow of refrigerant gas or liquid to maintain a constant upstream (or inlet) pressure as set-for, despite load fluctuations.

The fluid temperature range for the A4 Series of Regulators is -45°C to 105°C (-50°F to 220°F).

## Principles of Operation (See Fig. 1)

The inlet pressure enters the space under the diaphragm through passage N. When the force created by the pressure exceeds the force of the range spring, the diaphragm is lifted off the pilot seat allowing pressure to enter on top of the power piston. This causes the power piston to move downward forcing the modulating plug to open and modulate to maintain constant inlet pressure. An increase in inlet pressure lifts the diaphragm further, allowing more pressure on top of the power piston and opening the valve wider. A decrease in inlet pressure causes the diaphragm to move closer to the pilot seat reducing the pressure on the top of the power piston and causing the closing spring to reduce the valve opening. The pressure on top of the power piston is controlled by the flow through the pilot seat and the bleed off through the bleed hole in the power piston and through the clearance between the piston and cylinder. A minimum of 0.14 bar (2 psi) pressure drop across the valve is required to open it fully.

The A4A Inlet Pressure Regulator therefore opens on a rise in the inlet pressure above its set point and closes on a drop in inlet pressure below its set point. The inlet pressure set point is not appreciably affected by variations in the outlet pressure.

## Manual Opening Stem

All Type A4A Regulators are provided with a manual opening stem. To open the regulator manually, back the stem out (turn counter-clockwise) until it stops. To put the regulator into automatic operation, turn the stem in (clockwise) until only the flats on the stem protrude from the packing nut.

## Adjustment

Install an accurate pressure gauge in the gauge port. Back the adjusting stem all the way out to stop. This will reduce the set point to its lowest level and cause the valve to open wide. Start the system, and when suction pressure is about the desired pressure, turn the adjusting stem in until the pressure gauge shows a slight rise in the inlet pressure. At this point the adjusting stem may be turned in (clockwise) to raise the pressure further, or backed out (counter-clockwise) to lower it; but the final adjustment should be made after the system has been operating for a period of time.

### INLET PRESSURE SETTING RANGES

Set Point Ranges	Approx. Pressure Change per Turn of Adjusting Screw	Factory Set Point (unless otherwise specified)
A: 0 to 10.3 bar (0 to 150 psig)	1.7 bar (25 psi)	2.8 bar (40 psig)
V: 500mm hg to 8.3 bar (20 in hg to 120 psig)	1.7 bar (25 psi)	1.0 bar (15 psig)
D: 5.2 to 19.3 bar (75 to 280 psig)	3.7 bar (53 psi)	9.7 bar (140 psig)

## Type A4AZ (See Figs 1 and 2)

### Description

The A4AZ Inlet Pressure Regulator is the basic building block from which most Series A4 variations are made. This regulator incorporates the specially designed Modudapter® to accommodate the Adaptomode® bolt on modules, providing unique modular construction and many control valve variations with the use of a few modules and kits. See page 3 for an explanation of "Basic Adaptomode Functions", describing modules, module placement and schematic pilot circuit flow diagrams for all variations covered within this bulletin.

The A4AZ regulator is a complete factory assembled and bench tested valve and, in itself, may be used as a basic inlet pressure regulator. In addition, this valve can easily be modified in the field to perform the function of the A4AS, A4AB or A4AD valve variations.

## Type A4AS (See Fig. 3)

### Description

The Type A4AS is an inlet pressure regulator with a pilot electric shut off. The integrally mounted solenoid must be energized for the valve to function as a regulator. When de-energized the regulator is closed regardless of inlet pressure.

### Purpose

The Type A4AS should be used whenever it is required to stop all flow (in the normal fluid flow direction) through the regulator. This could include use in defrost applications as well as part of a temperature control system.

### Principles of Operation

The operation of the A4AS is the same as that described on page 1, except the inlet pressure from passage N must pass through the S6A Pilot Solenoid Valve before it can reach the diaphragm. Thus the S6A Pilot Solenoid must be energized before the A4AS can begin to regulate regardless of inlet pressure.

### Adjustment

With the solenoid pilot electrically energized, proceed as described above.

## Type A4AB (See Fig. 4)

### Description

The Type **A4AB** is an Inlet Pressure Regulator with a Pilot Electric Wide-opening, or Bypass, variation. When the integrally mounted solenoid is energized the main valve is wide open, thereby bypassing the regulator function i.e. not regulating. However, in the wide open

mode the regulator will still require the 0.14 bar (2 psi) minimum pressure drop. When the solenoid is de-energized the valve functions as an Inlet Pressure Regulator.

### Purpose

The Type A4AB frequently is used with the wide-open function where maximum refrigeration capacity from an evaporator is required. During the defrost of the evaporator, the regulator pilot solenoid is de-energized thus functioning as a defrost relief regulator or for high pressure limit protection.

When used in a discharge pressure line, it can when de-energized, hold back enough pressure for some heat reclaim or defrosting function and then, when energized, allow the discharge pressure to drop to a lower level. Frequently this regulator is used in the wide open mode for evaporator pump out prior to hot gas defrost.

### Principles of Operation

The operation of the A4AB is the same as that described on page 1 when operating as a regulator (Pilot Solenoid de-energized). When the solenoid is energized the upstream pressure from passage N bypasses the underside of the diaphragm and is fed directly to the top of the piston where, provided a 0.14 bar (2 psi) pressure difference exists across the main valve, the Modulating Plug will be held wide open.

### Adjustment

With the solenoid pilot electrically de-energized, proceed as described above.

## Type A4AD (See Fig. 5)

### Description

The Type A4AD is a Dual Inlet Pressure Regulator capable of regulating at two different pressure set-points. When the integrally mounted S6A Pilot Solenoid Valve is energized the regulator is controlling at the lower of two set-points, which must be adjusted on the pressure pilot over the center of the main valve. When the solenoid is de-energized the regulator is controlling at the higher set-point, which must be adjusted on the bolt-on (outboard) pressure pilot.

### Purpose

The Type A4AD uses are similar to those for the A4AB except, instead of operating in a wide-open position when the pilot solenoid is energized, the regulator is controlling at some preset level.

Typical uses include capacity control of an evaporator at two different pressure levels to regulate temperature, and evaporator pressure control combined with defrost pressure relief.

### Principles of Operation

The operation of the A4AD is similar to that described on page 1. When the Pilot Solenoid is energized, upstream pressure from passage N is made available to both diaphragms. Since the path of least resistance will be through the Pressure Pilot with the lower set-point (lower range spring force) that pilot will control.

When the Pilot Solenoid is de-energized, upstream pressure from passage N can flow only to the high pressure pilot, which will then control the regulator.

### Adjustment

Electrically de-energize the solenoid pilot and adjust the modular (bolt-on) pressure pilot for the desired high pressure setting following the adjusting procedure as described above. Energize the solenoid pilot and adjust the integral pressure pilot for the desired low pressure setting following the adjusting procedure described above.

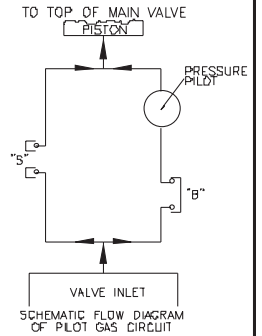
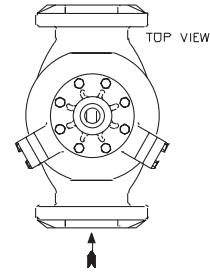
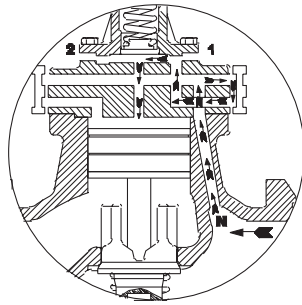

**Fig 2 A4AZ**

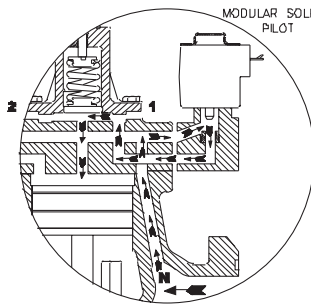

SOLENOID ENERGIZED:  
VALVE REGULATES

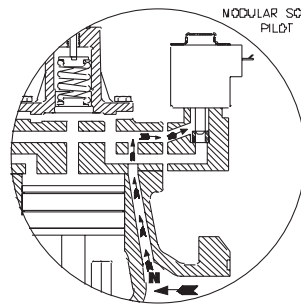

SOLENOID DE-ENERGIZED:  
VALVE CLOSED

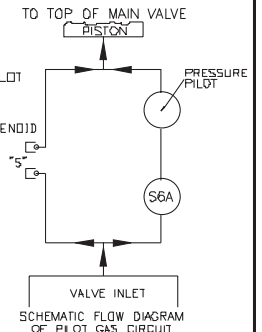
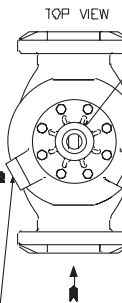

MODUPLATE WITH  
"S" SHOWING

**Fig 3 A4AS**

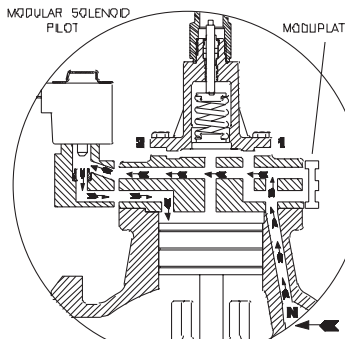

SOLENOID ENERGIZED:  
VALVE WIDE OPEN

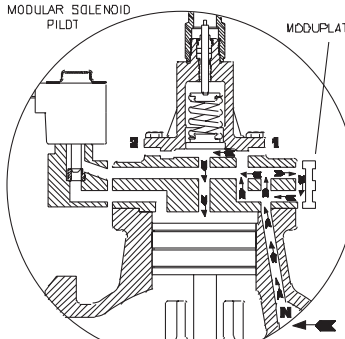

SOLENOID DE-ENERGIZED:  
VALVE REGULATES  
INLET PRESSURE

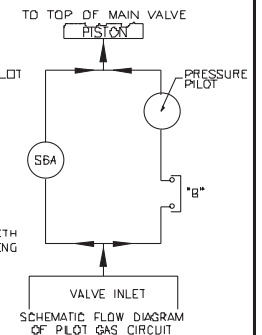
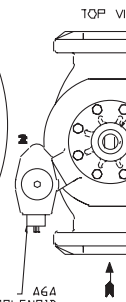

PILOT SOLENOID

**Fig 4 A4AB**

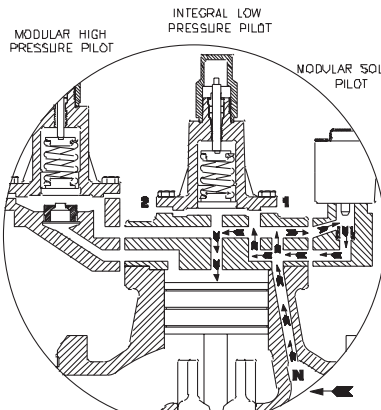

SOLENOID DE-ENERGIZED:  
LOW PRESSURE PILOT  
CONTROLS VALVE

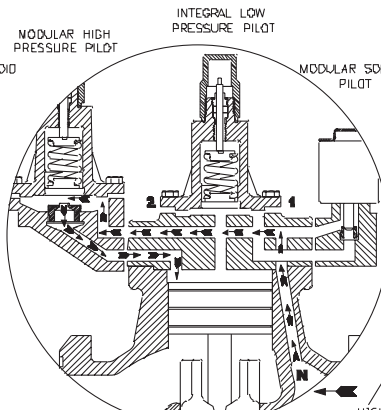

SOLENOID DE-ENERGIZED:  
HIGH PRESSURE PILOT  
CONTROLS VALVE

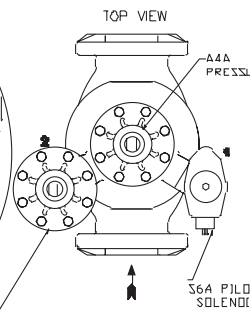

HIGH PRESSURE PILOT  
42D2 (20mm-50mm) 3/4"-2"  
A2D (60mm-100mm) 2-1/2"-4"

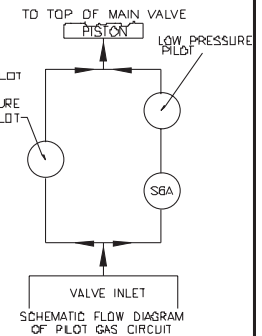
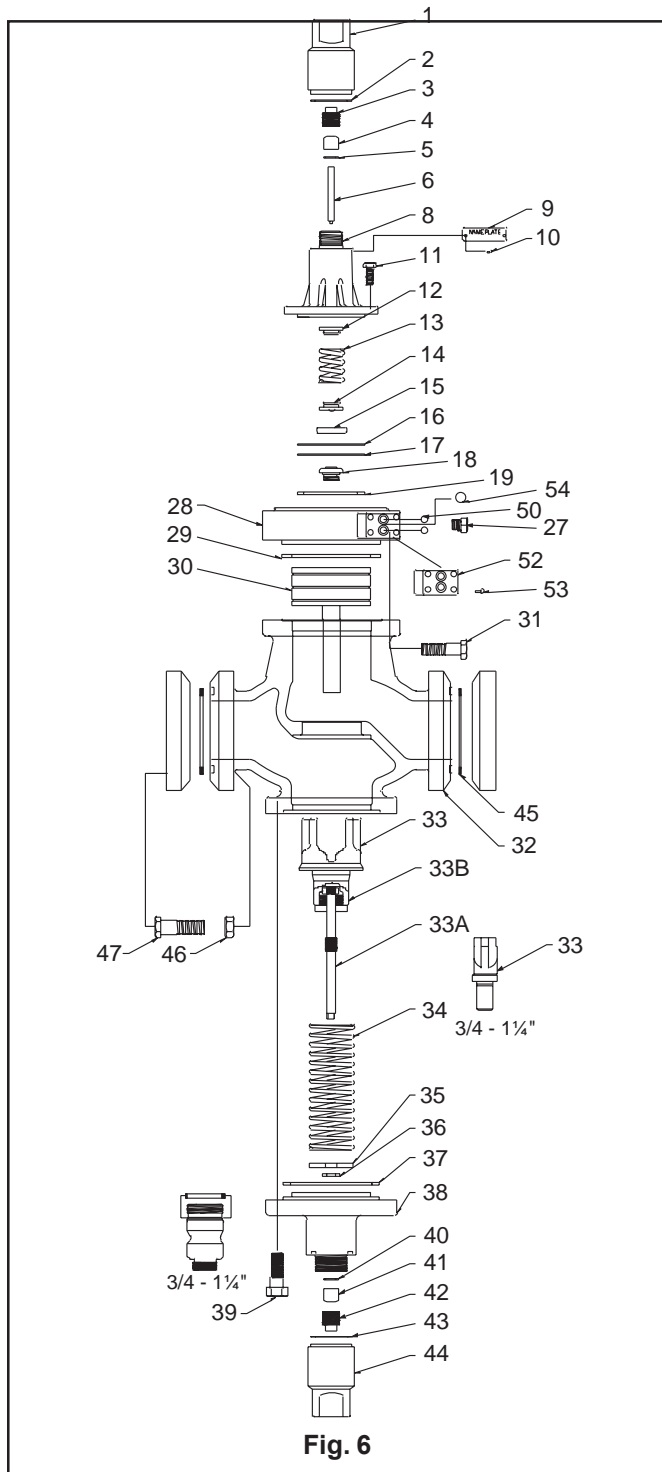

**Fig 5 A4AD**

## Installation

All regulators are packed for maximum protection. Unpack carefully. Check the carton to make sure all flanges and other items are unpacked. Save the enclosed instructions for the installer and eventual user.

Do not remove the protective coverings from the inlet and outlet of the regulator until the regulator is ready to be installed. Protect the inside of the regulator from moisture, dirt and chips before and during installation. When welded or brazed flange connections are used, all slag, scale and loose particles should be removed from the flange interior before the regulator is installed between the flanges. It is advisable to install a close-coupled companion strainer (RSF) at the inlet of the regulator to help protect it from any foreign material in the system.



The A4A series of regulators will give optimum performance if mounted in a horizontal line in a vertical position with the manual opening stem on bottom. Where other positions are desired, the factory should be consulted; please give application and piping details. The regulator must be installed with the arrow on the valve body pointing in the direction of the fluid flow for the regulator to function properly. Backward flow through the regulator is uncontrolled and will vary with the valve model and the reverse pressure drop encountered. The regulator is not a check valve.

Tighten the flange bolts and nuts evenly to provide proper seating of the flange gasket and to avoid damage to gaskets or flanges. (See Flange Bolt Torque Table, page 16) Avoid using the regulator flange bolts to stretch or align pipe. Even the heavy duty semisteel body of an A4A can be distorted, causing the precision parts to bind.

The regulator should be installed in a location where it is easily accessible for adjustment and maintenance. The location should be such that the regulator can not be easily damaged by material handling equipment. When it is necessary to insulate the regulator (and companion strainer), the insulation should be installed to provide access to the regulator (and companion strainer) for adjustment and maintenance. Do not insulate the solenoid coil and coil housing. Proper indicating gauges should be installed to be easily visible to the operating engineer for system checking and adjusting purposes.

## Disassembly and Assembly

Refer to the exploded views, Figs. 6 and 7, in this section.

Before disassembling any A4A type regulator, read the information in this bulletin and Bulletin RSB, Safety Procedures for Refrigerating Specialties Division Refrigeration Control Valves.

Before a regulator is removed from the line or disassembled in the line, make sure that all refrigerant has been removed from the regulator, including the bonnet where applicable, and the close coupled strainer. The regulator must be isolated from the rest of the system in a safe manner. When pumping down to remove the refrigerant, the manual opening stem 33A must be turned out (counter clockwise) to make sure the valve is open.

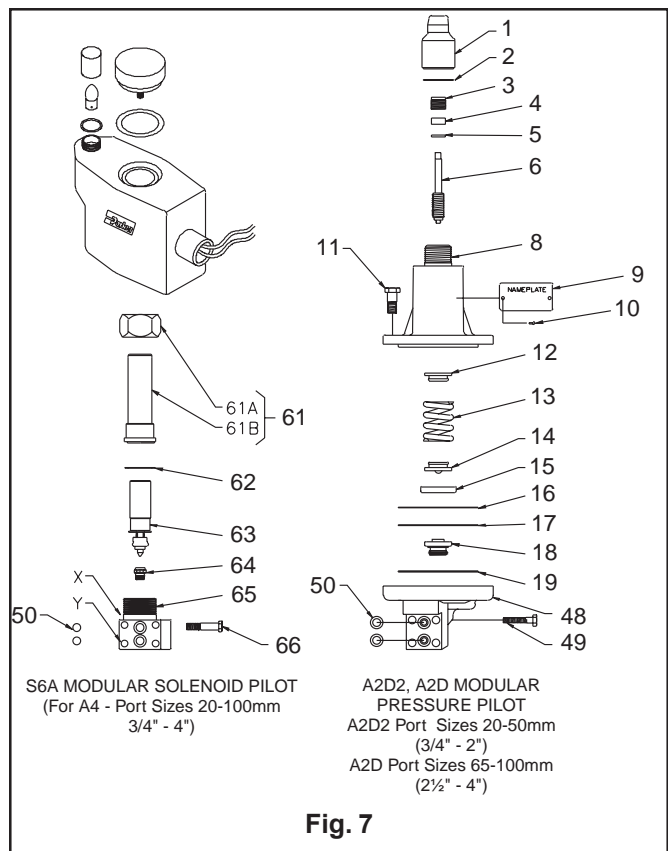

## Disassembly and Assembly (continued)

### All A4A Regulators General Procedure

The construction of the regulator and the method of disassembly are relatively simple, but some procedures must be followed to avoid damage. The following describes the procedure for the basic A4A; special instructions for other types are included in other appropriate sections.

**Disassembly** - Take care when removing Seal Caps 1 and 44 in case some refrigerant may be trapped inside. Back the Adjusting Stem 6 all the way out to remove any pressure from Range Spring 13 otherwise damage to Diaphragm 17 or Pilot Seat 18 may occur. Remove Bonnet 8 by carefully removing Cap Screws 11. Take care not to damage Diaphragm Follower 15. Remove Adapter 28 by removing Cap Screws 31. Turn the Manual Opening Stem 33A all the way in until the flats on the stem barely protrude from the stuffing box nut. Push Piston 30 down against the spring force. The piston should move freely down and be returned by the spring force. If the piston is jammed or sticky, remove Bottom Cap Assembly which includes Items 33 through 42 by removing Cap Screws 39 or unscrewing Bottom Cap, 20mm through 32mm (3/4" through 1-1/4"). Using a hard wood dowel rod inserted

through the bottom of the valve, tap the piston upward and out. Thoroughly clean all parts. If jamming has taken place and the piston and bore are scored, remove all burrs by polishing the piston, bore and throttling plug with fine crocus cloth. Inspect the seating area of the Throttling Plug 33 for damage or erosion. If damaged it should be replaced. It would be advisable to replace the entire bottom cap assembly. Inspect all gaskets and "O" rings for damage and replace where necessary.

**Assembly** - When reassembling the valve, all internal parts should be clean, dry and lightly oiled with refrigerant oil, except "O" rings. Apply silicone grease to the "O" rings. Care must be taken especially when the parts are cold since moisture can condense on parts and cause rapid rusting. When replacing gaskets, they should be oiled very lightly with refrigerant oil before assembly. Install bottom cap assembly first and tighten in place. Carefully replace the piston; never try to force it in place. Align the Adapter Gasket 29 carefully with the proper holes in the adapter and valve body and fasten adapter in place. Before assembling the bonnet be sure the Adjusting Stem 6 is turned all the way out and that the Bonnet 8 and Diaphragm Follower 15 are properly aligned, otherwise damage to the diaphragm and pilot seat may occur. Place Gasket 19 in the adapter and align Gasket 16 and Diaphragm 17 to the center of the bonnet. The raised center of the diaphragm must be towards the bonnet. For range "D" use two diaphragms. Tighten Cap Screws 11 evenly. The ideal tightening torque is 1.5 Kg-m (11 ft. lbs.). Valve is now ready to be adjusted for normal operation.

If close coupled strainer is used, it may be cleaned before putting the valve back in operation. The regulator must be tested for leaks with refrigerant gas or other appropriate gas before the system is put into operation.

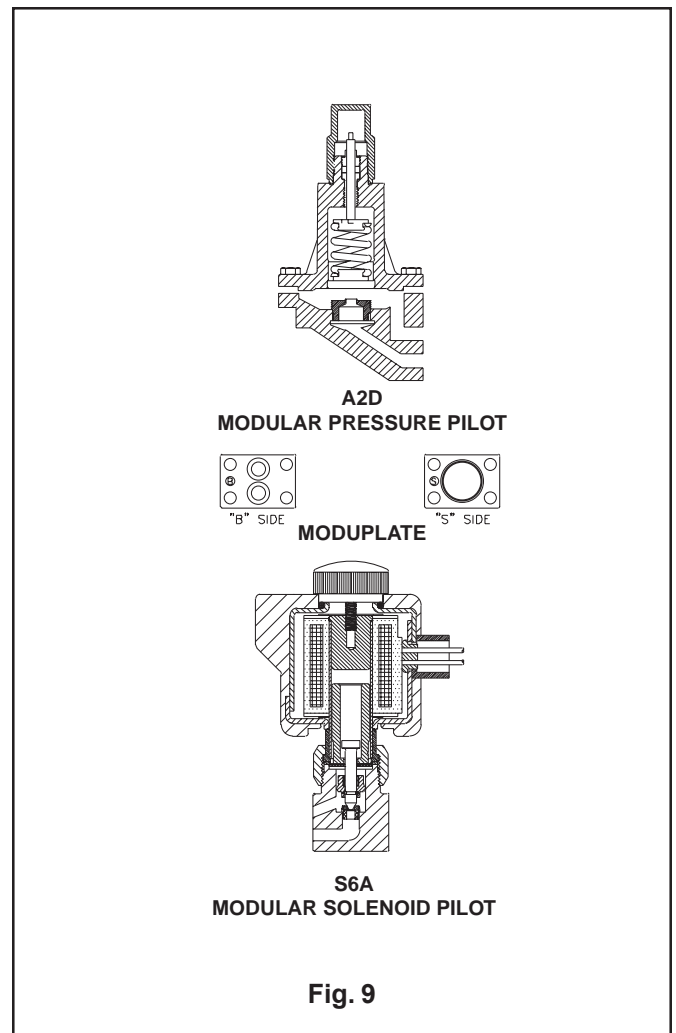
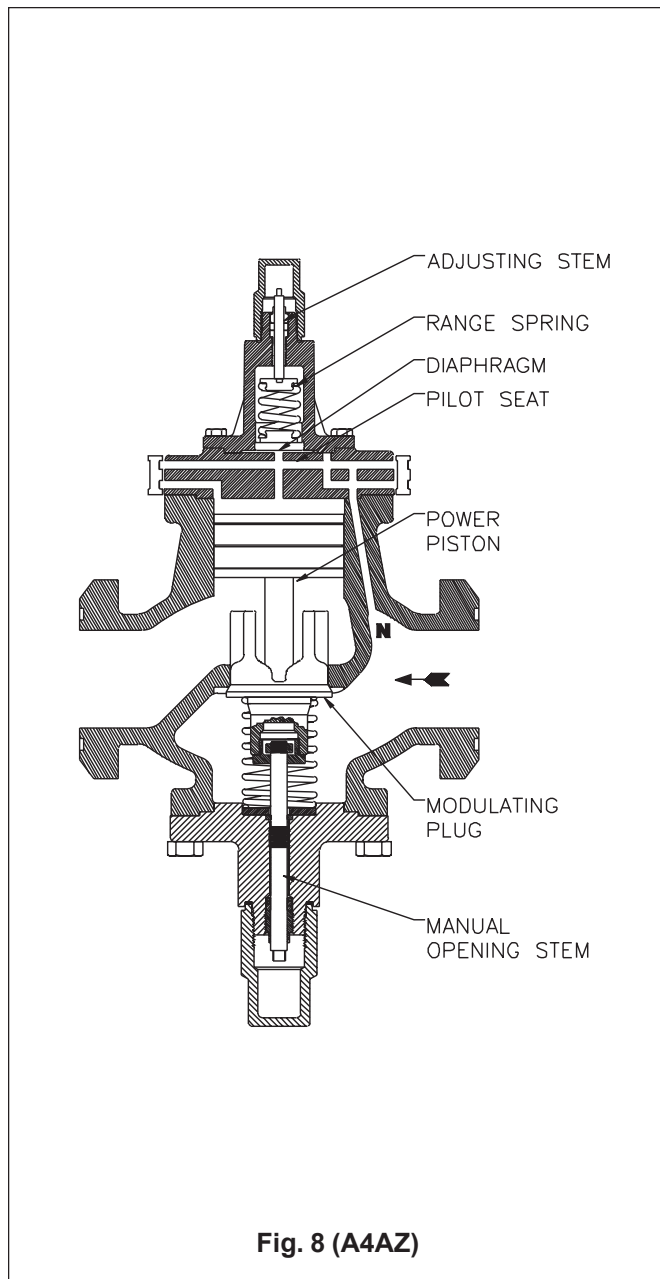



## Disassembly and Assembly (continued)

### Basic Modules Disassembly and Assembly

Refer to exploded views (Figs. 10 and 11) and also page 3 for explanation of "Basic Adaptomode Functions" to assist in clarification of module placement, as discussed in this section. Before disassembling and assembling any modules, refer to page 4 of this bulletin and to Bulletin RSB, Safety Procedure for Refrigerating Specialties Division Refrigeration Control Valves.

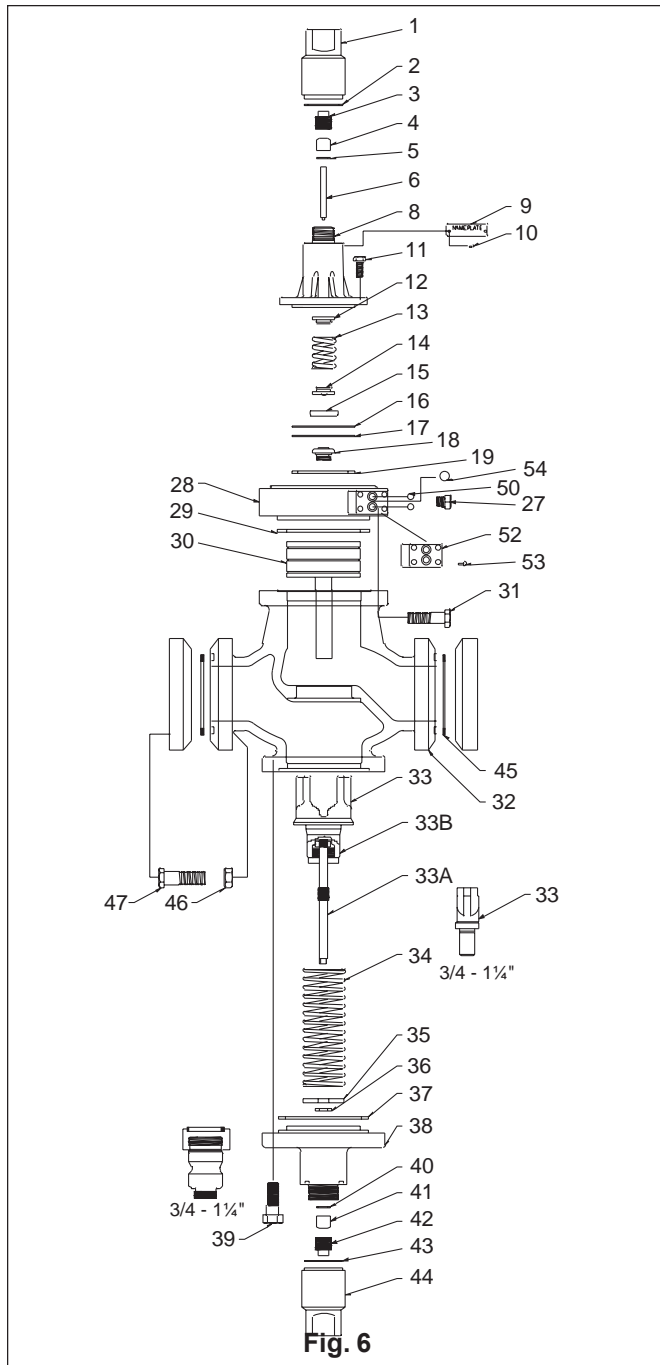

### Moduadapter

The Moduadapter 28 will accommodate the Modular Pilots and Moduplates illustrated on page 3. When assembling make sure the Moduadapter gauge port is directly lined up with the inlet of the regulator. Passage N must communicate upstream pressure through the hole in Adapter Gasket 29 as well as into Moduadapter 28 and thence to the pilot modules. It is imperative that proper alignment of these items be made to assure regulator function.

Before disassembly, make sure all refrigerant has been removed from the regulator and strainer, if used.

Protect the surfaces of Pads 1 and 2 of the Moduadapter at all times since these surfaces determine the sealing tightness of the "O" Rings.

### A2D, A2D2 Modular Pressure Pilots (Figs. 11 and 12)

These pressure pilots are used where a dual pressure regulator is desired and is mounted on Pad 2. Follow the disassembly and assembly procedure for the A4A pilot (pages 4 and 5). When mounting the pilot, place the "O" Rings 50 into the proper grooves and tighten the Cap Screws 49 evenly. The ideal tightening torque is 1.1 Kg-m (8 ft. lbs).

### S6A Modular Solenoid Pilot (Figs. 10 and 12)

This solenoid pilot may be mounted on either Pad 1 or 2 depending on the function desired (see pages 2 and 3). Before working on any solenoid pilot, make sure the coil is de-energized and will remain so during the servicing period.

**Disassembly (Fig. 10)** - Remove Coil Housing Screw 55 and pull entire Coil and Housing Assembly, 56 through 60, upward and off of Bonnet-Tube Assembly 61. Carefully remove Bonnet-Tube Assembly. Lift out Plunger-Needle Assembly 63, avoid damaging the needle. Remove Seat Assembly 64 by using a 7/16" (11 mm) socket wrench. Inspect all parts, clean or replace as needed.

**Assembly (Fig. 10)** - Reinstall the Seat Assembly and tighten (no gasket needed). Carefully insert the Plunger Needle Assembly. Replace the Gasket 62 and reinstall Bonnet-Tube Assembly. Replace entire Coil and Housing Assembly and tighten Coil Housing Screw.

Make sure the solenoid coil is of the proper voltage and frequency.

When mounting the solenoid pilot, place the "O" Rings 50 into the proper grooves and tighten the Cap Screws 66, evenly. The ideal tightening torque is 1.1 kg-m (8 ft. lbs.).

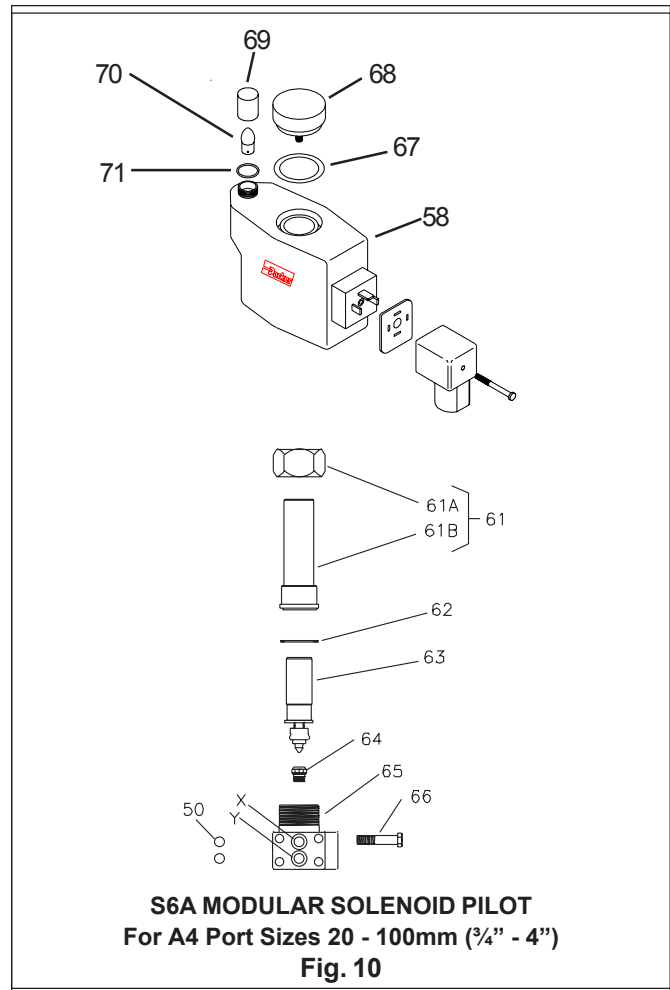

**S6A MODULAR SOLENOID PILOT**  
For A4 Port Sizes 20 - 100mm (3/4" - 4")  
Fig. 10

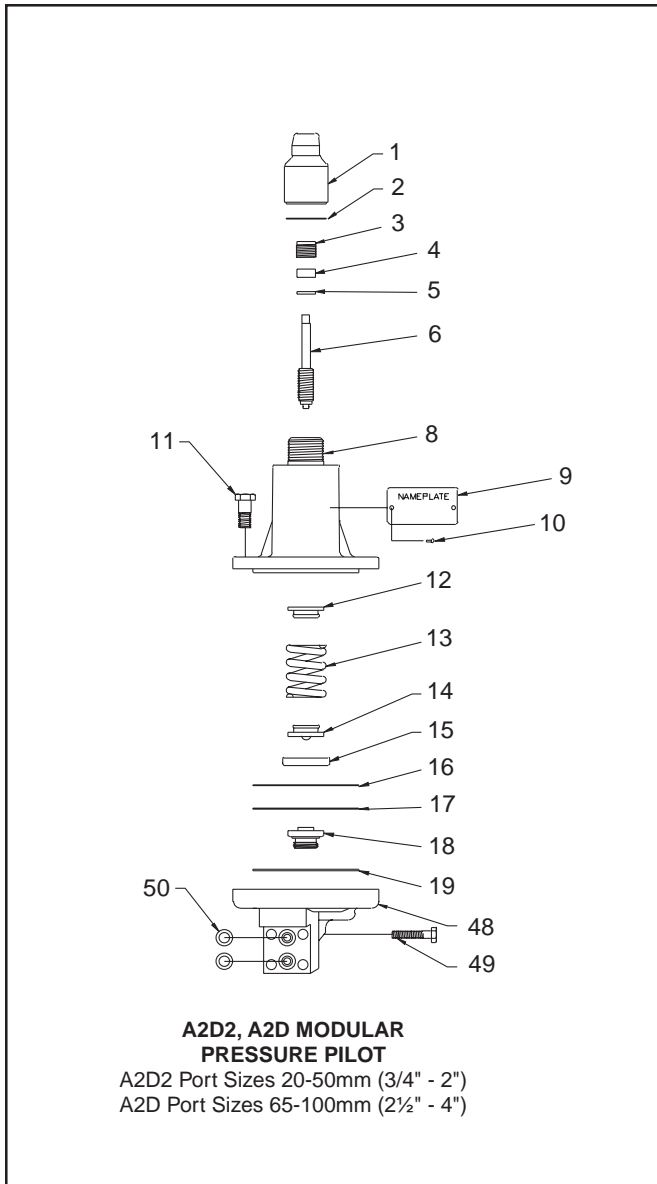

Check the manual opening stem; it should be turned in for automatic operation.

Check the regulator setting to make sure it is properly adjusted. Turn adjusting screw slowly to see if regulator responds. Check regulator pressure range; if wrong, range spring must be replaced.

Check other system components for proper operation. Make sure that the regulator receives the proper electrical signal where modular pilot solenoids are used. Make sure they are same as the power supply.

Check hand valves in the system to make sure they are open or closed as required and the system is receiving liquid or gas as the case may be.

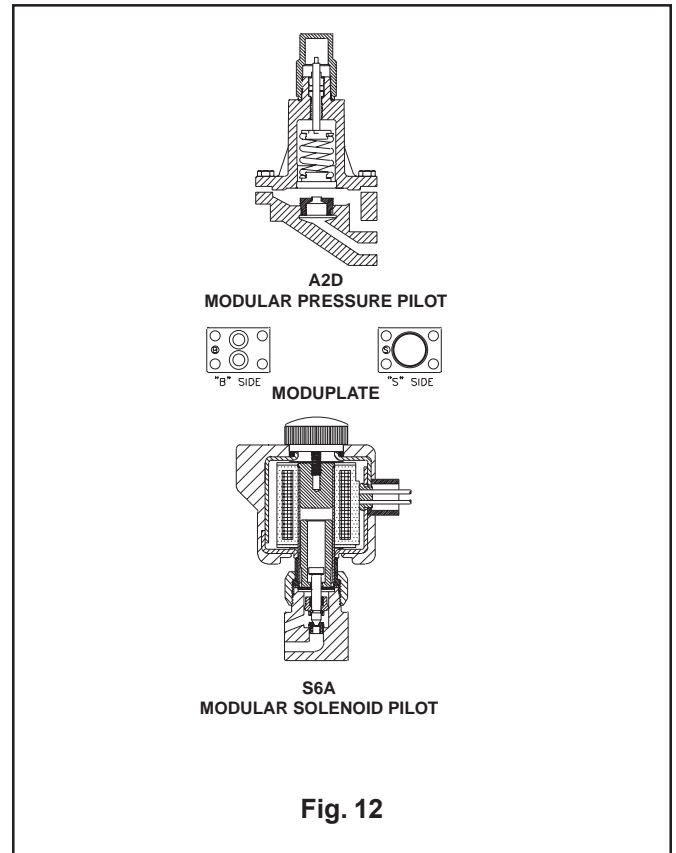

### Moduplate (Figs. 6 and 12)

These Moduplates 52 are used to direct the flow or stop the flow through the flow paths of the Moduadapter. Protect the "O" Ring surfaces at all times. When mounting the Moduplate, place "O" Rings 50 (or "O" Ring 54) into the proper grooves (lubricate with silicone grease) and tighten the Cap Screws 53 evenly to avoid distortion and assure proper sealing. The ideal tightening torque is 1.1 Kg-m (8 ft. lbs.).

### Maintenance and Service General Procedure:

Before disassembly of regulator, make certain that all refrigerant has been removed (pumped out) from the regulator and its companion strainer where one is used. Read Safety Bulletin RSB.

Dirt in the system is the greatest single cause of regulator malfunction. All screens or filters must be cleaned or replaced when they become dirty. At start up it is especially important that these items are cleaned or changed frequently. When the RSF close-coupled companion strainers are used, maintain according to instructions in Bulletin 00-10. Moisture in halocarbon systems in particular can cause corrosion or form ice, causing the piston to freeze in position. Filter-driers should be used and maintained for halocarbon systems.

Before deciding to disassemble a regulator for servicing, the following investigations should be made:

### Solenoid Coils and Coil Housing

The solenoid coils and coil housing, identified and described on page 8 for the Type S6A Solenoid Pilot, are an improved design which provide a higher MOPD and a cooler coil resulting in longer life. The new coil and its heavily plated, rust resisting housing are interchangeable with the obsolete coil and cast iron housing as follows: The new coil, which has its Part Number stamped on the side, can be used in both the old and new coil housing; the old coil which has its 30-0030-XX Series Part Number stamped on one end, can be used in the old, cast iron housing only. There is no bottom marking on the new coil; either end may be positioned up. The color coding of lead wires for various voltage and frequencies has not been changed. The fuses used with the old coils are suitable for the new coils; the new coil power consumption is 33 Watts instead of 37.

The S6A pilot solenoid valve is also available with a coil using a quick electrical connector or plug, permitting easy wiring connection with an exposed rubber covered cable instead of a rigid or flexible conduit and enclosed wiring. This type of coil cannot be used with the old, cast Iron housing.

The new coils and new housing described above for the S6A valve are also used with Solenoid Valve Types S4, S5, S6N, S7, S8 and S9.

## Maintenance and Service (continued)

### Electrical

The Refrigerating Specialties Division molded water resistant Class "B" solenoid coil is designed for long life and powerful opening force. The standard coil housing meets NEMA 3R and 4 requirements. This sealed construction can withstand direct contact with moisture and ice. The coil housing far exceeds the requirements of NEMA Standard ICS, 1-110.57 salt spray test for rust resistance.

By definition, Class "B" coil construction will permit coil temperatures, as measured by resistance method, as high as 130°C (266°F). Final coil temperatures are a function of both fluid and ambient temperatures. The higher fluid temperatures require lower ambient temperatures so the maximum coil temperature is not exceeded. Conversely, low fluid temperatures permit higher ambient temperatures.

The molded Class "B" coil is available from stock with most standard voltages. However, coils are available for other voltages and frequencies, as well as for direct current. Coils are also available as transformer type with a 6 volt secondary winding for use with the Refrigerating Specialties Division Pilot Light Assembly (see current copy of Bulletin 60-10, "Pilot Light Assembly and Solenoid Transformer Coil").

The solenoid coil must be connected to electrical lines with volts and Hertz same as stamped on coil. The supply circuits must be properly sized to give adequate voltage at the coil leads even when other electrical equipment is operating. The coil is designed to operate with line voltage from 85% to 110% of rated coil voltage. Operating with a line voltage above or below these limits may result in coil burnout. Also, operating with line voltage below the limit will definitely result in lowering the valve opening pressure differential. Power consumption during normal operation will be 33 watts or less.

Inrush and running current is listed below:

Standard Coil Volts/Hertz	Inrush Current (Amps)	Running Current (Amps)	Fuse Size (Amps)
120/60 (Blue leads)	1.1860	0.46	1
208/60 (Blue & Red leads)	0.63	0.26	1
240/60 (Red leads)	0.60	0.23	1
440/60 (Yellow & Red leads)	0.39	0.13	1
115/50 (Yellow & Blue leads)	1.22	0.21	1
230/50 (Yellow leads)	0.65	0.26	1
Other	Contact Factory		

On transformer coil the 6 volt leads are always black.

### SERVICE POINTERS (Check General Procedure)

SYMPTOM	PROBABLE REASON	CORRECTION
Regulator does not shut off flow.	Diaphragm or seat dirty, damaged or frozen.	Clean or replace. Clean strainer.
	Diaphragm follower stuck or damaged.	Clean or replace. Install follower carefully.
	Piston jammed with excess dirt.	Remove and polish piston and bore with crocus cloth. Clean valve and strainer.
	Throttling plug leaking due to excess dirt or damage.	Clean or replace. If used on liquid, check for erosion due to excessive flash gas. Reduce flash gas by subcooling or by reducing pressure drop across valve by providing restriction at valve outlet.
	Diaphragm ruptured or badly deformed.	Replace. If Range "D" make sure has 2 diaphragms.
	A4AB Modular Solenoid Pilot seat leaking.	Check seat and needle. Replace as needed.
	A4AS Modular Solenoid Pilot seat leaking.	Check seat and needle. Replace as needed.
	Diaphragm and seat eroded due to flash gas.	Replace. Reduce flash gas by subcooling or by reducing pressure drop across regulator by providing restriction at valve outlet.
Regulator does not open	Modular Solenoid Pilot not closing.	Check power at leads, make sure coil is de-energized.
	A4A (inlet) Pressure Regulator Diaphragm ruptured or badly deformed.	Replace. If Range D make sure has 2 diaphragms.
	Diaphragm follower stuck, damaged or frozen.	Clean or replace. Install follower carefully.
	A4AS/A4AB Modular Solenoid Pilot not opening.	Pressure drop across valve too high; over 21 bar (300 psig). Lower pressure drop. Improper power supply. Correct. Replace solenoid coil.
Regulator Operation erratic.	Piston worn, too much clearance.	Replace piston. Check for reason. If used on liquid, check for flash gas.
	Diaphragm or seat dirty or damaged.	Clean or replace. Clean strainer.
	Diaphragm follower has dirt on the outside diameter or outside diameter is damaged.	Clean or replace.
	Other system components, line controllers, thermostats, etc., erratic.	Adjust, repair or replace.
Pressure drop across regulator too high.	Regulator too far oversized.	Check load. Replace with smaller regulator or investigate use of reduced capacity plug.
	Inlet or outlet restricted.	Check for restriction. Clean strainer.
	Regulator too small.	Open manually to be sure valve is full open. Replace with proper size regulator.
	Large amount of flash gas in liquid line.	Reduce flash gas by subcooling. Reduce line restriction by increasing line size, particularly at the regulator outlet. Replace with larger regulator.
	High pressure drop causes high rate of expansion of gas at regulator outlet.	Increase pipe size at the outlet of the regulator.
Regulator does not open all the way.	Check piston for wear. Replace, if needed.	



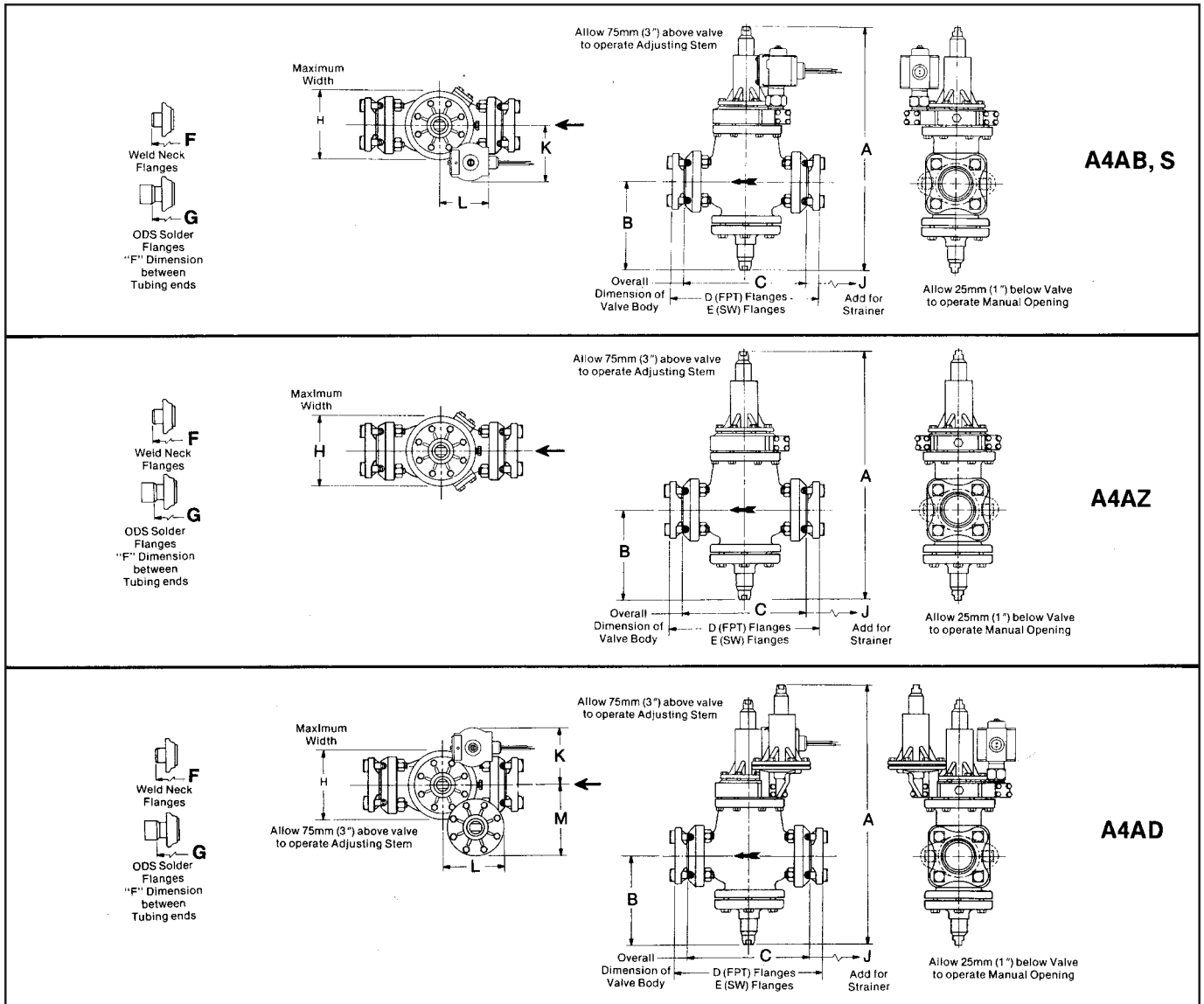
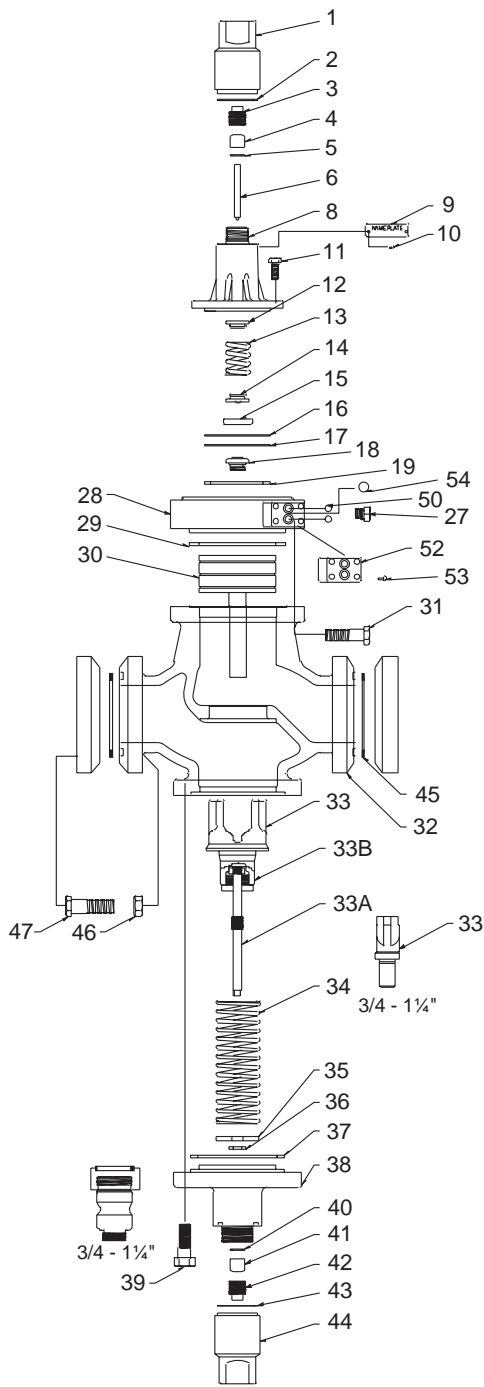

TABLE OF DIMENSIONS FOR INLET PRESSURE REGULATORS Types A4AS, A4AB, A4AD and A4AZ												Types A4AS, A4AB & A4AZ 100mm (4")		Type A4AD only 100mm (4")							
Type	20mm & 25mm (3/4 & 1")		32mm (1-1/4")		40mm & 50mm (1-5/8 & 2")		65mm (2-1/2")		75mm (3")		mm	inch	mm	inch							
DIMENSION	mm	inch	mm	inch	mm	inch	mm	inch	mm	inch											
A	429	16.9	447	17.6	500	19.7	513	20.2	632	24.9	685	27.0	685	27.0							
B	148	5.8	162	6.3	177	6.9	181	7.1	273	10.7	292	11.5	292	11.5							
C	164	6.2	203	8.0	251	9.9	251	9.9	311	12.2	339	14.1	339	14.1							
(D) (FPT) for PIPE SIZES SHOWN	1/2"	216	8.5	1-1/4"	256	10.1	1-1/2"	307	12.1	2-1/2"	331	13.0	3"	389	15.3	4"	450	17.7	4"	450	17.7
	3/4"	216	8.5																		
	1"	216	8.5	1-1/2"	256	10.1	2"	307	12.1												
	1-1/4"	216	8.5																		
(E) (SW) FOR PIPE SIZES SHOWN	1/2"	216	8.5	1-1/4"	256	10.1	1-1/2"	307	12.1	2-1/2"	331	13.0	3"	389	15.3	4"	450	17.7	4"	450	17.7
	3/4"	216	8.5																		
	1"	216	8.5	1-1/2"	256	10.1	2"	307	12.1												
	1-1/4"	216	8.5																		
(F) (WN) FOR PIPE SIZES SHOWN	—	—	—	1-1/4"	300	11.8	1-1/2"	364	14.3	2-1/2"	401	15.6	3"	478	18.8	4"	571	22.5	4"	571	22.5
	3/4"	254	10.0																		
	1"	261	10.3	1-1/2"	304	12.0	2"	371	14.6												
	1-1/4"	261	10.3																		
(G) (ODS) FOR TUBE SIZES SHOWN	7/8"	239	9.4	1-3/8"	269	10.6	1-5/8"	358	14.1	2-5/8"	348	13.7	3-1/8"	414	16.3	4-1/8"	503	19.8	4-1/8"	503	19.8
	1-1/8"	239	9.4																		
	1-3/8"	231	9.1	1-5/8"	279	11.0	2-1/8"	338	13.3	3-1/8"	389	15.3	3-5/8"	432	17.0						
	1-5/8"	239	9.4	2-1/8"	305	12.0	2-5/8"	358	14.1												
H	117	4.6	117	4.6	140	5.5	159	6.2	178	7.0	222	8.8	222	8.8	222	8.8	222	8.8	222	8.8	
J	98	3.9	178	7.0	251	9.9	314	12.4	314	12.4	363	14.3	363	14.3	363	14.3	363	14.3	363	14.3	
K	112	4.4	112	4.4	117	4.6	124	4.9	142	5.6	158	6.2	157	6.2							
L	122	4.8	122	4.8	135	5.3	133	5.2	122	4.8	152	6.0	140	5.5							
M	138	5.4	138	5.4	140	5.5	150	5.9	170	6.6	190	7.7	190	7.7							

# Repair Kits for A4AS, A4AB, A4AD and A4AZ



Item No.	Description	20mm (3/4")		25mm (1")	
		Kit No.	Qty	Kit No.	Qty
1	Seal Cap	Only Avail. with Kit	1	Only Avail. with Kit	1
2	Seal Cap Gasket	Only Avail. with Kit	1	Only Avail. with Kit	1
1-2	Cap Kit, Seal	202110	1	202110	1
3	Nut, Packing	Only Avail. with Kit	1	Only Avail. with Kit	1
4	Packing, Stem	Only Avail. with Kit	1	Only Avail. with Kit	1
5	Washer, Flat	Only Avail. with Kit	1	Only Avail. with Kit	1
3-5,6	Packing Kit, Stem	202100	1	202100	1
6	Stem, Adjusting	Only Avail. with Kit	1	Only Avail. with Kit	1
4-6	Stem Kit, Adjusting	202120	1	202120	1
12	Plate, Spring, Upper	Only Avail. with Kit	1	Only Avail. with Kit	1
13	Spring, Comp.	Only Avail. with Kit	1	Only Avail. with Kit	1
14	Plate, Spring, Lower	Only Avail. with Kit	1	Only Avail. with Kit	1
15	Follower, Diaphragm	Only Avail. with Kit	1	Only Avail. with Kit	1
3-5,6, 12-15	Spring/ Stem Kit	Rge. AV 202006	1	202006	1
		Rge. D 202007	1	202007	1
8	Bonnet	Only Avail. with Kit	1	Only Avail. with Kit	1
11	Screw, Hx.Hd.	Only Avail. with Kit	8	Only Avail. with Kit	8
16	Bonnet Gasket	Only Avail. with Kit	1	Only Avail. with Kit	1
1-6,8, 11-16	Spring Kit with Bonnet	Rge. AV 202008	1	202008	1
		Rge. D 202009	1	202009	1
12-14, 16	Spring Kit, less Bonnet	Rge. AV 202481	1	202481	1
		Rge. D 202482	1	202482	1
17	Diaphragm	Only Avail. with Kit	1	Only Avail. with Kit	1
19	Gasket	Only Avail. with Kit	1	Only Avail. with Kit	1
16,17,19	Diaphragm Kit	Rge. AV 200770	1	200770	1
17	Diaphragms	Rge. D Only Avail. with Kit	2	Only Avail. with Kit	2
16,17,19	Diaphragm Kit	Rge. D 200771	1	200771	1
16-19	VC Vacuum Cartridge	Only Avail. with Kit	1	Only Avail. with Kit	1
16-19	Pilot Seal/ Diaphragm Kit (Not A4A0)	Rge. A 202000	1	202000	1
		Rge. V 202004	1	202004	1
		Rge. D 202002	1	202002	1
27	Plug Pkg, 1/4" NPT	202552	5	202552	5
28	Adapter	Only Avail. with Kit	1	Only Avail. with Kit	1
29	Gasket	Only Avail. with Kit	1	Only Avail. with Kit	1
19,27,28, 29,31	Adapter Kit	200591	1	200591	1
30	Piston/Stem Assembly	Only Avail. with Kit	1	Only Avail. with Kit	1
29,30	Piston Kit	200760	1	200760	1
32	Valve Body	Not Available		Not Available	
34	Spring, Comp.	Only Avail. with Kit	1	Only Avail. with Kit	1
35	Washer, Flat	Only Avail. with Kit	1	Only Avail. with Kit	1
36	Wiper, Dirt	Only Avail. with Kit	1	Only Avail. with Kit	1
37	"O" Ring	Only Avail. with Kit	1	Only Avail. with Kit	1
34-37	Spring Kit, Closing	(A4A) 202300	1	202300	1
		(A4AK) 202298	1	202298	1
33	Plug/Stem Assembly	Only Avail. with Kit	1	Only Avail. with Kit	1
40	Washer, Flat	Only Avail. with Kit	1	Only Avail. with Kit	1
41	Packing, Stem	Only Avail. with Kit	1	Only Avail. with Kit	1
42	Nut, Packing	Only Avail. with Kit	1	Only Avail. with Kit	1
33,34-37, 40-42	Full Cap. Plug Kit, Modul.	202021	1	202022	1
33,34-37, 40-42	50% Cap. Plug Kit, Modul.	202029	1	(*)	
33,34-37, 40-42	35% Cap. Plug Kit, Modul.	Not Available		Not Available	
33,34-37, 40-42	17% Cap. Plug Kit, Modul.	202030	1	(*)	

\* All Plug Kits and Bottom Assembly Kits for 3/4" Port Size Valves can be used in the 1" Port Size Valves for reducing capacity.

## Repair Kits for A4AS, A4AB, A4AD and A4AZ

Item No.	32mm (1-1/4")		40mm (1-5/8")		50mm (2")		65mm (2-1/2")		75mm (3")		100mm (4")	
	Kit No.	Qty	Kit No.	Qty	Kit No.	Qty	Kit No.	Qty	Kit No.	Qty	Kit No.	Qty
1	Only Avail. with Kit	1	Only Avail. with Kit	1	Only Avail. with Kit	1	Only Avail. with Kit	1	Only Avail. with Kit	1	Only Avail. with Kit	1
2	Only Avail. with Kit	1	Only Avail. with Kit	1	Only Avail. with Kit	1	Only Avail. with Kit	1	Only Avail. with Kit	1	Only Avail. with Kit	1
1-2	202110	1	202110	1	202110	1	202110	1	202110	1	202110	1
3	Only Avail. with Kit	1	Only Avail. with Kit	1	Only Avail. with Kit	1	Only Avail. with Kit	1	Only Avail. with Kit	1	Only Avail. with Kit	1
4	Only Avail. with Kit	1	Only Avail. with Kit	1	Only Avail. with Kit	1	Only Avail. with Kit	1	Only Avail. with Kit	1	Only Avail. with Kit	1
5	Only Avail. with Kit	1	Only Avail. with Kit	1	Only Avail. with Kit	1	Only Avail. with Kit	1	Only Avail. with Kit	1	Only Avail. with Kit	1
3-5	202100	1	202100	1	202100	1	202100	1	202100	1	202100	1
6	Only Avail. with Kit	1	Only Avail. with Kit	1	Only Avail. with Kit	1	Only Avail. with Kit	1	Only Avail. with Kit	1	Only Avail. with Kit	1
4-6	202120	1	202120	1	202120	1	202120	1	202120	1	202120	1
12	Only Avail. with Kit	1	Only Avail. with Kit	1	Only Avail. with Kit	1	Only Avail. with Kit	1	Only Avail. with Kit	1	Only Avail. with Kit	1
13	Only Avail. with Kit	1	Only Avail. with Kit	1	Only Avail. with Kit	1	Only Avail. with Kit	1	Only Avail. with Kit	1	Only Avail. with Kit	1
14	Only Avail. with Kit	1	Only Avail. with Kit	1	Only Avail. with Kit	1	Only Avail. with Kit	1	Only Avail. with Kit	1	Only Avail. with Kit	1
15	Only Avail. with Kit	1	Only Avail. with Kit	1	Only Avail. with Kit	1	Only Avail. with Kit	1	Only Avail. with Kit	1	Only Avail. with Kit	1
3-5,6, 12-15	202006	1	202006	1	202006	1	202006	1	202006	1	202006	1
	202007	1	202007	1	202007	1	202007	1	202007	1	202007	1
8	Only Avail. with Kit	1	Only Avail. with Kit	1	Only Avail. with Kit	1	Only Avail. with Kit	1	Only Avail. with Kit	1	Only Avail. with Kit	1
11	Only Avail. with Kit	8	Only Avail. with Kit	8	Only Avail. with Kit	8	Only Avail. with Kit	8	Only Avail. with Kit	8	Only Avail. with Kit	8
16	Only Avail. with Kit	1	Only Avail. with Kit	1	Only Avail. with Kit	1	Only Avail. with Kit	1	Only Avail. with Kit	1	Only Avail. with Kit	1
1-6,8, 11-16	202008	1	202008	1	202008	1	202008	1	202008	1	202008	1
	202009	1	202009	1	202009	1	202009	1	202009	1	202009	1
12-14, 16	202481	1	202481	1	202481	1	202481	1	202481	1	202481	1
	202482	1	202482	1	202482	1	202482	1	202482	1	202482	1
17	Only Avail. with Kit	1	Only Avail. with Kit	1	Only Avail. with Kit	1	Only Avail. with Kit	1	Only Avail. with Kit	1	Only Avail. with Kit	1
19	Only Avail. with Kit	1	Only Avail. with Kit	1	Only Avail. with Kit	1	Only Avail. with Kit	1	Only Avail. with Kit	1	Only Avail. with Kit	1
16,17,19	200770	1	200770	1	200770	1	200770	1	200770	1	200770	1
17	Only Avail. with Kit	2	Only Avail. with Kit	2	Only Avail. with Kit	2	Only Avail. with Kit	2	Only Avail. with Kit	2	Only Avail. with Kit	2
16,17,19	200771	1	200771	1	200771	1	200771	1	200771	1	200771	1
16-19	Only Avail. with Kit	1	Only Avail. with Kit	1	202004	1	202004	1	202004	1	202004	1
	202000	1	202000	1	202000	1	202001	1	202001	1	202001	1
16-19	202004	1	202004	1	202004	1	202004	1	202004	1	202004	1
	202002	1	202002	1	202002	1	202003	1	202003	1	202003	1
27	202552	5	202552	5	202552	5	202552	5	202552	5	202552	5
28	Only Avail. with Kit	1	Only Avail. with Kit	1	Only Avail. with Kit	1	Only Avail. with Kit	1	Only Avail. with Kit	1	Only Avail. with Kit	1
29	Only Avail. with Kit	1	Only Avail. with Kit	1	Only Avail. with Kit	1	Only Avail. with Kit	1	Only Avail. with Kit	1	Only Avail. with Kit	1
19,27,28, 29,31	200593	1	200595	1	200595	1	200597	1	200599	1	200606	1
30	Only Avail. with Kit	1	Only Avail. with Kit	1	Only Avail. with Kit	1	Only Avail. with Kit	1	Only Avail. with Kit	1	Only Avail. with Kit	1
29,30	200767	1	200389	1	200389	1	200391	1	200393	1	200227	1
32	Not Available		Not Available		Not Available		Not Available		Not Available		Not Available	
34	Only Avail. with Kit	1	Only Avail. with Kit	1	Only Avail. with Kit	1	Only Avail. with Kit	1	Only Avail. with Kit	1	Only Avail. with Kit	1
35	Only Avail. with Kit	1	Only Avail. with Kit	1	Only Avail. with Kit	1	Only Avail. with Kit	1	Only Avail. with Kit	1	Only Avail. with Kit	1
36	Only Avail. with Kit	1	Only Avail. with Kit	1	Only Avail. with Kit	1	Only Avail. with Kit	1	Only Avail. with Kit	1	Only Avail. with Kit	1
37	Only Avail. with Kit	1	Only Avail. with Kit	1	Only Avail. with Kit	1	Only Avail. with Kit	1	Only Avail. with Kit	1	Only Avail. with Kit	1
34-37	202301	1	202302	1	202302	1	202303	1	202304	1	202305	1
	202299	1	202302	1	202302	1	202303	1	202304	1	202305	1
33	Only Avail. with Kit	1	Only Avail. with Kit	1	Only Avail. with Kit	1	Only Avail. with Kit	1	Only Avail. with Kit	1	Only Avail. with Kit	1
40	Only Avail. with Kit	1	Only Avail. with Kit	1	Only Avail. with Kit	1	Only Avail. with Kit	1	Only Avail. with Kit	1	Only Avail. with Kit	1
41	Only Avail. with Kit	1	Only Avail. with Kit	1	Only Avail. with Kit	1	Only Avail. with Kit	1	Only Avail. with Kit	1	Only Avail. with Kit	1
42	Only Avail. with Kit	1	Only Avail. with Kit	1	Only Avail. with Kit	1	Only Avail. with Kit	1	Only Avail. with Kit	1	Only Avail. with Kit	1
33,34-37, 40-42	202023	1	202024	1	202025	1	202026	1	202027	1	202028	1
33,34-37, 40-42	Not Available		Not Available		Not Available		Not Available		Not Available		Not Available	
33,34-37, 40-42	202031	1	202032	1	(**)		202033	1	202034	1	202035	1
33,34-37, 40-42	Not Available		Not Available		Not Available		Not Available		Not Available		Not Available	
	Not Available		Not Available		Not Available		Not Available		Not Available		Not Available	

\*\*All Plug Kits and Bottom Assembly Kits for 1-5/8" Port Size Valves can be used in the 2" Port Size Valves for reducing capacity.

# Repair Kits for A4AS, A4AB, A4AD and A4AZ

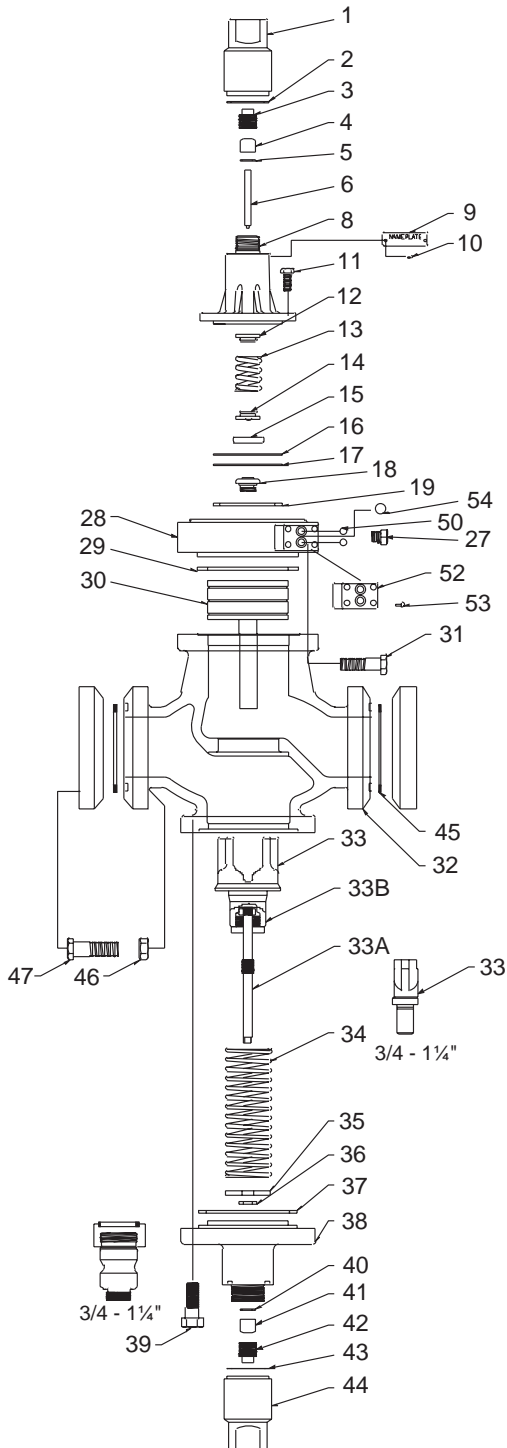

Item No.	Description	20mm (3/4")		25mm (1")		
		Kit No.	Qty	Kit No.	Qty	
37	"O" Ring	Only Avail. with Kit	1	Only Avail. with Kit	1	
38	Cover, Bottom	Only Avail. with Kit	1	Only Avail. with Kit	1	
40	Washer, Flat	Only Avail. with Kit	1	Only Avail. with Kit	1	
41	Packing, Stem	Only Avail. with Kit	1	Only Avail. with Kit	1	
37,38,40,41	Cover Kit	200761	1	200761	1	
42	Nut, Packing	Only Avail. with Kit	1	Only Avail. with Kit	1	
40-42	Packing Kit, Stem	202100	1	202100	1	
43	Gasket	Only Avail. with Kit	1	Only Avail. with Kit	1	
44	Seal Cap	Only Avail. with Kit	1	Only Avail. with Kit	1	
43,44	Seal Cap, Kit	202110	1	202110	1	
33-38,	Full Cap. Bottom	A4A	202010	1	202011	1
40-44	Assembly Kit	A4AK	202018	1	202019	1
33-38,	50% Cap. Bottom	A4A	202347	1	(*)	1
40-44	Assembly Kit	A4AK	202348	1	(*)	1
33-38,	17% Cap. Bottom	A4A	202346	1	(*)	1
40-44	Assembly Kit	A4AK	Not Available		Not Available	
3-6, 12-19,	Full Cap. Repair	Rge. A	202041	1	202044	1
29, 30, 33-37,	Kit, Reg. (All	Rge. V	202040	1	202043	1
40-42	except A4AK)	Rge. D	202042	1	202045	1
3-6, 12-19,	50% Cap. Repair	Rge. A	202352	1	(*)	1
29-30, 33-37,	Kit, Reg. (All	Rge. V	202354	1	(*)	1
40-42	except A4AK)	Rge. D	202353	1	(*)	1
3-6, 12-19,	17% Cap. Repair	Rge. A	202349	1	(*)	1
29-30, 33-37,	Kit, Reg. (All	Rge. V	202351	1	(*)	1
40-42	except A4AK)	Rge. D	202350	1	(*)	1
112	Cover, Top	Only Avail. with Kit	1	Only Avail. with Kit	1	
29,112	A4AR Cover Kit	200680	1	200680	1	
2,16(2),19(2),	<b>Gasket Kits (includes complete set of gaskets plus "O" Rings If applicable)</b>					
25, 26, 29, 37,	Gasket Kit A4/S4	202112		202112		
43,45(3)	<b>Indv'l Gaskets, "O" Rings &amp; Valve Pk'g sold &amp; pkg'd in qtls only as Indicated.</b>					
29	Gasket Pkg, Adapter	202406	5	202406	5	
37	"O" Ring/Gasket Pkg. Bottom Cap	202384	3	202384	3	
43	Gasket Pkg, Seal Cap (Bottom)	202408	12	202408	12	
2	Gasket Pkg, Seal Cap (Top)	202408	12	202408	12	
45	Gasket Pkg, Flange	202079	12	202079	12	
4	Packing Pkg, Stem (Top)	202478	25	202478	25	
41	Packing Pkg, Stem (Bottom)	202478	25	202478	25	
<b>Bolt Package Kits</b>						
11	Bolt Package, A4A Bonnet	202246	8	202246	8	
31	Bolt Package, Adapter	202248	8	202249	8	
39	Bolt Package, Bottom Cap	Not Required		Not Required		
<b>Flange Bolt Package Includes bolts and nuts; no gaskets</b>						
46	Nut	5/8"-11	2	5/8"-11	2	
47	Bolt	5/8"-11x3"	2	5/8"-11x3"	2	
46,47	Bolt Kit, Flange	201585	1	201585	1	
50,52-54	Moduplate Kit "MP"	200518		200518		
52	Moduplate	Only Avail. with Kit	1	Only Avail. with Kit	1	
54	O-Ring, "B"	Only Avail. with Kit	1	Only Avail. with Kit	1	
50	O-Ring, "S", "D"	Only Avail. with Kit	2	Only Avail. with Kit	2	

Flange Kit	FK-25				FK-25			
	FPT, SW, WN		ODS		FPT, SW, WN		ODS	
	Std	Also Avail.	Std	Also Avail.	Std	Also Avail.	Std	Also Avail.
Kit includes 2 Flanges only Connections Available Sizes in Inches	3/4	1, 1-1/4	7/8	1-1/8, 1-3/8	1	3/4, 1-1/4	1-1/8	1-3/8, 1-5/8

\* All Plug Kits and Bottom Assembly Kits for 3/4" Port Size Valves can be used in the 1" Port Size Valves for reducing capacity.

# Repair Kits for A4AS, A4AB, A4AD and A4AZ

Item No.	32mm (1-1/4")		40mm (1-5/8")		50mm (2")		65mm (2-1/2")		75mm (3")		100mm (4")	
	Kit No.	Qty	Kit No.	Qty	Kit No.	Qty	Kit No.	Qty	Kit No.	Qty	Kit No.	Qty
37	Only Avail. with Kit	1										
38	Only Avail. with Kit	1										
40	Only Avail. with Kit	1										
41	Only Avail. with Kit	1										
37,38,40,41	200761	1	Not Available		Not Available		Not Available		Not Available		Not Available	
42	Only Avail. with Kit	1	Only Avail. with Kit	1	Only Avail. with Kit	1	Only Avail. with Kit	1	Only Avail. with Kit	1	Only Avail. with Kit	1
40-42	202100	1	202100	1	202100	1	202100	1	202101	1	202101	1
43	Only Avail. with Kit	1	Only Avail. with Kit	1	Only Avail. with Kit	1	Only Avail. with Kit	1	Only Avail. with Kit	1	Only Avail. with Kit	1
44	Only Avail. with Kit	1	Only Avail. with Kit	1	Only Avail. with Kit	1	Only Avail. with Kit	1	Only Avail. with Kit	1	Only Avail. with Kit	1
43,44	202110	1	202110	1	202110	1	202110	1	202111	1	202111	1
33-38,	202012	1	202013	1	202014	1	202015	1	202016	1	202017	1
40-44	202020	1	202013	1	202014	1	202015	1	202016	1	202017	1
33-38,	Not Available		Not Available		Not Available		Not Available		Not Available		Not Available	
40-44	Not Available		Not Available		Not Available		Not Available		Not Available		Not Available	
33-38,	Not Available		Not Available		Not Available		Not Available		Not Available		Not Available	
40-44	Not Available		Not Available		Not Available		Not Available		Not Available		Not Available	
3-6, 12-19,	202047	1	202050	1	202053	1	202056	1	202059	1	202062	1
29, 30, 33-37,	202046	1	202049	1	202052	1	202055	1	202058	1	202061	1
40-42	202048	1	202051	1	202054	1	202057	1	202060	1	202063	1
3-6, 12-19,	NOTE: 50% Capacity Repair Kit is not available for port sizes 1-1/4" to 4". Capacity reduction can be obtained through use of field installing "Reduced Capacity Plug Kits". See description and contents of these kits elsewhere this section.											
29-30, 33-37,	NOTE: 17% Capacity Repair Kit is not available for port sizes 1-1/4" to 4". Capacity reduction can be obtained through use of field installing "Reduced Capacity Plug Kits". See description and contents of these kits elsewhere this section.											
40-42	NOTE: 17% Capacity Repair Kit is not available for port sizes 1-1/4" to 4". Capacity reduction can be obtained through use of field installing "Reduced Capacity Plug Kits". See description and contents of these kits elsewhere this section.											
112	Only Avail. with Kit	1	Only Avail. with Kit	1	Only Avail. with Kit	1	Only Avail. with Kit	1	Only Avail. with Kit	1	Only Avail. with Kit	1
29,112	200669	1	200673	1	200673	1	200690	1	200676	1	200677	1
7,16(2),19(2)	<b>Gasket Kits (includes complete set of gaskets plus "O" Rings if applicable)</b>											
25,26,29,37	202113		202114		202114		202115		202116		202117	
43,45(3)	<b>Individual Gaskets, '10" Rings and Valve Packing sold and packaged in quantities only as indicated.</b>											
29	202407	5	202397	3	202397	3	202396	3	202399	3	202400	3
37	202384	3	202374	6	202374	6	202374	6	202382	3	202383	3
43	202408	12	202408	12	202408	12	202408	12	202404	5	202404	5
2	202408	12	202408	12	202408	12	202408	12	202408	12	202408	12
45	202080	12	202081	12	202081	12	202082	12	202083	12	202084	12
4	202478	25	202478	25	202478	25	202478	25	202478	25	202478	25
41	202478	25	202478	25	202478	25	202478	25	202479	5	202479	5
<b>Bolt Package Kits</b>												
11	202246	8	202246	8	202246	8	202246	8	202246	8	202246	8
31	202248	8	202249	8	202249	8	202249	8	202250	6	202250	6
39	Not Required		202251	6	202251	6	202251	6	202252	6	202252	6
<b>Flange Bolt Package Includes bolts and nuts; no gaskets</b>												
46	5/8"-11	4	5/8"-11	4	5/8"-11	4	3/4"-10	4	3/4"-10	4	7/8"-9	4
47	5/8"-11x2-3/4"	4	5/8"-11x3-1/4"	4	5/8"-11x3-1/4"	4	3/4"-10x3-3/4"	4	3/4"-10x3-3/4"	4	7/8"-9x4-1/2"	4
46,47	201595	1	201604	1	201604	1	201611	1	201611	1	201620	1
50,52-54	200518		200518		200518		200518		200518		200518	
52	Only Avail. with Kit	1	Only Avail. with Kit	1	Only Avail. with Kit	1	Only Avail. with Kit	1	Only Avail. with Kit	1	Only Avail. with Kit	1
54	Only Avail. with Kit	1	Only Avail. with Kit	1	Only Avail. with Kit	1	Only Avail. with Kit	1	Only Avail. with Kit	1	Only Avail. with Kit	1
50	Only Avail. with Kit	2	Only Avail. with Kit	2	Only Avail. with Kit	2	Only Avail. with Kit	2	Only Avail. with Kit	2	Only Avail. with Kit	2

	FK-32				FK-40				FK-50				FK-65				FK-75				FK-100			
	FPT, SW WN		ODS		FPT, SW WN		ODS		FPT, SW WN		ODS		FPT, SW WN		ODS		FPT, SW WN		ODS		FPT, SW WN		ODS	
	Std.	Also Avail.	Std.	Also Avail.	Std.	Also Avail.	Std.	Also Avail.	Std.	Also Avail.	Std.	Also Avail.	Std.	Also Avail.	Std.	Also Avail.	Std.	Also Avail.	Std.	Also Avail.	Std.	Also Avail.		
	1-1/4	1-1/2	1-3/8	1-5/8, 2-1/8	1-1/2	2	1-5/8	2-1/8, 2-5/8	2	1-1/2	2-1/8	2-5/8	2-1/2		2-5/8	3-1/8	3		3-1/8	3-5/8	4		4-1/8	



## Repair Parts Kits for A2D2 and A2D Modular Pressure Pilots

Item	Description	Oty.	Kit Number
1-2	Seal Cap Kit	1	202110
3-5	Packing Kit/Stem	1	202100
3-6, 12-15	Spring/Stem Kit	Rge. A/V	1 202006
		Rge. D	1 202007
1-6,8 11-16	Bonnet/Spring Kit	Rge. A/V	1 202008
		Rge. D	1 202009
12-14, 16	Spring Kit, Bonnet	Rge. A/V	1 202481
		Rge. D	1 202482
16,17 19	Diaphragm Kit	Rge. A/V	1 200770
		Rge. D	1 200771 <sub>u</sub>
u Rge. D Diaphragm Kit has two (2) Diaphragms			
16-19	Seat Kit, Pilot	Rge. A	1 202001
		Rge. V	1 202004
		Rge. D	1 202003
48	Body		Not available separately
49-50	Bolt/"O" Ring Kit	Bolts	4 201572
		"O"Ring	2

Note: Pressure Pilot A2D2 used on main valve sizes 3/4" to 2" port.  
Pressure Pilot A2D used on main valve sizes 2-1/2" to 4" port.

Repair Kits indicated for the A2D2 and A2D are common parts used on the integral pressure pilot mounted on the A4A Series Regulator.

### Spare or Additional A2D2 and A2D Repair Kit Packages

Note: The following items are included in the above Kits in the exact numbers as required for field repair. If additional "O" Rings, Gaskets or Stem Packing are desired for spares or future use, order from the following listing:

Item	Description	Oty.	Kit Package Number
2	Gasket Pkg./Seal Cap	12	202408
50	"O"Ring Pkg/Moduplate	12	202424
4	Stem Packing, Pkg.	25	202478

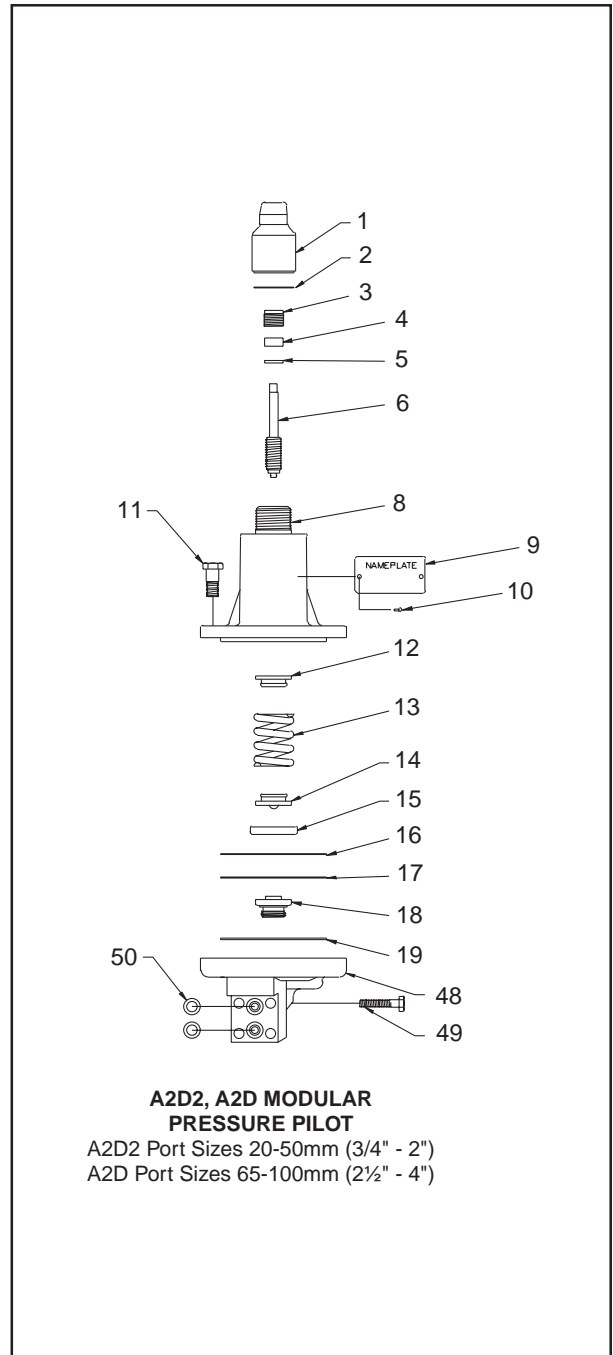

## Repair Parts Kits for S6A Modular Pressure Pilot Solenoid

Item	Description	Oty.	Kit Number
55	Screw	1	Only Available with Kit
58	Coil Assembly	1	Consult Factory
67	O-Ring	1	Only Available with Kit
68	Knob	1	Only Available with Kit
67, 68	Knob Kit	1	205047
69	Lens	1	Only Available with Kit
70	Bulb Kit	6	205282
71	O-Ring	1	Only Available with Kit
69, 71	Lens Kit	6	205279
61B	Tube Assembly, Solenoid	1	Only Available with Kit
61A	Nut, Solenoid Tube	1	Only Available with Kit
62	Gasket	1	Only Available with Kit
61A, 61B 62	Tube Kit, Solenoid	1	201036
50	"O" Ring	2	Only Available with Kit Also available in package. See below.
66	Bolts	4	Only Available with Kit
50,66	Bolt/"O" Ring Kit	1	201574
62	Gasket	1	Only Available with Kit
63	Plunger/Needle Assembly	1	Only Available with Kit
62,63	Plunger Kit, Needle	1	201019
62	Gasket	1	Only Available with Kit
63	Plunger/Needle Assembly	1	Only Available with Kit
62, 63	Plunger Kit, Needle (D.C only)	1	201021
62	Gasket	1	Only Available with Kit
63	Plunger/Needle Assembly	1	Only Available with Kit
64	Seat Assembly	1	Only Available with Kit
62,63,64	Plunger Seat Kit	1	201630
50	"O" Ring Pkg., Moduplate	12	202424
65	Body S6A	1	Not Available Separately

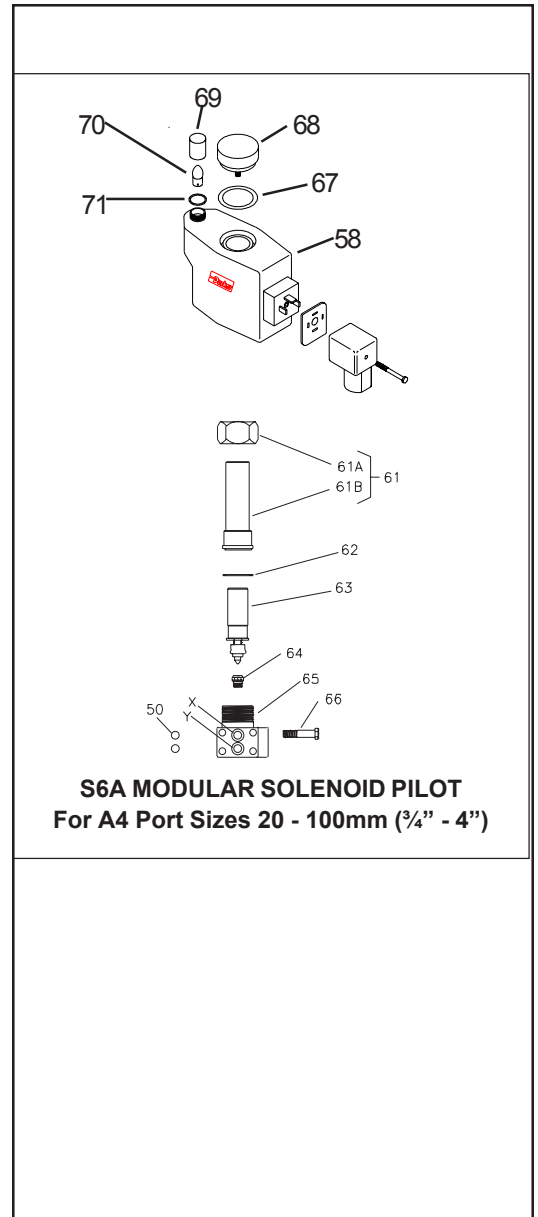

## FLANGES

VALVE SIZE		Ã FPT FLANGES		WELDING FLANGES								Ã FLANGES				
		Nom. Pipe Size	Flange Pkg. No. (2/Pkg)	Nominal Pipe Size		Sock Weld Socket I.D.		Weld Neck Neck O.D.		Flange Package Number(2/Pkg)		Tubing O.D.		Fitting I.D.		Flge Pkg. No. (2/Pkg)
				Inches	Ã	Inches	mm	Inches	mm	Socket Weld	Weld Neck	Inches	Ã	Inches	mm	
20	3/4	3/4	200016	3/4	NW 20	1.070	27.81	1.050	26.67	200020	200023	1-1/8	28.57	1.130	28.70	200027
and	and	1	200017	1	25	1.365	34.67	1.315	33.40	200021	200024	1-3/8	34.92	1.380	33.05	200028
25	1	1-1/4	200018	1-1/4	32	1.705	43.31	1.660	42.16	200022	200025	1-5/8	41.27	1.631	41.43	200029
32	1-1/4	1-1/4	200030	1-1/4	32	1.705	43.31	1.660	42.16	200032	200034	1-3/8	34.92	1.380	35.05	200036
		1-1/2	200031	1-1/2	40	1.930	49.02	1.900	48.26	200033	200035	1-5/8	41.27	1.631	41.43	200037
												2-1/8	53.97	2.131	54.13	200038
40	1-5/8	1-1/2	200039	1-1/2	40	1.930	49.02	1.900	48.26	200041	200043	1-5/8	41.27	1.631	41.43	200045
and	and	2	200040	2	50	2.445	62.10	2.375	60.33	200042	200044	2-1/8	53.97	2.131	54.13	200046
50	2											2-5/8	66.67	2.631	66.83	200047
65	2-1/2	2-1/2	200048	2-1/2	65	2.945	—	2.875	73.03	200049	200050	2-5/8	66.67	2.631	66.83	200051
												3-1/8	79.37	3.131	79.53	200052
75	3	3	200053	3	80	3.575	90.81	3.500	88.90	200054	200055	3-1/8	79.37	3.131	79.53	200056
													3-5/8	92.07	3.631	92.23
100	4	4	200062	4	100	4.575	116.20	4.500	114.30	200063	200064	4-1/8	104.77	4.132	104.95	200065

Ã FPT: Internal NPT (USA Standard Taper Pipe Thread).

Ã NW: Metric equivalent nominal size for steel tubing.

Ã Metric copper tubing used for refrigeration.

Ã ODS connections to fit copper tubing of given outside diameter. (Not for use with ammonia)

### Definitions:

ODS - Outside Diameter Sweat

I.D. - Inside Diameter

O.D. - Outside Diameter

N.A. - Not Available

**Flange Bolt Torque Requirements**

Bolt Diameter	Valve Port Size	Torque
11mm (7/16")	13mm (1/2")	3.9 mkg (28 ft lb)
16mm (5/8")	20-50mm (3/4" - 2")	11.8 mkg (85 ft lb)
19mm (3/4")	65-75mm (2-1/2" - 3")	14.5 mkg (105 ft lb)
22mm (7/8")	100mm (4")	22.1 mkg (150 ft lb)

## Safe Operation (See also Bulletin RSBCV)

People doing any work on a refrigeration system must be qualified and completely familiar with the system and the Refrigerating Specialties Division valves involved, or all other precautions will be meaningless. This includes reading and understanding pertinent Refrigerating Specialties Division product Bulletins, and Safety Bulletin RSB prior to installation or servicing work.

Where cold refrigerant liquid lines are used, it is necessary that certain precautions be taken to avoid damage which could result from liquid expansion. Temperature increase in a piping section full of solid liquid will cause high pressure due to the expanding liquid which can possibly rupture a gasket, pipe or valve. All hand valves isolating such sections should be marked, warning against accidental closing, and must not be closed until the liquid is removed. Check valves must never be installed upstream of solenoid valves, or regulators with electric shutoff, nor should hand valves upstream of solenoid valves or downstream of check valves be closed until the liquid has been removed. It is advisable to properly install relief devices in any section where liquid expansion could take place.

Avoid all piping or control arrangements which might produce thermal or pressure shock.

For the protection of people and products, all refrigerant must be removed from the section to be worked on before a valve, strainer, or other device is opened or removed.

Flanges with ODS connections are not suitable for ammonia service.

## Warranty

All Refrigerating Specialties Products are warranted against defect in workmanship and materials for a period of one year from date of shipment from factory. This warranty is in force only when products are properly installed, field assembled, maintained and operated in use and service as specifically stated in Refrigerating Specialties Catalogs or Bulletins for normal refrigeration applications, unless otherwise approved in writing by Refrigerating Specialties Division. Defective products, or parts thereof, returned to the factory with transportation charges prepaid and found to be defective by factory inspection will be replaced or repaired at Refrigerating Specialties' option, free of charge, F.O.B. factory. Warranty does not cover products which have been altered or repaired in the field; damaged in transit, or have suffered accidents, misuse, or abuse. Products disabled by dirt, or other foreign substances will not be considered defective.

THE EXPRESS WARRANTY SET FORTH ABOVE CONSTITUTES THE ONLY WARRANTY APPLICABLE TO REFRIGERATING SPECIALTIES PRODUCTS, AND IS IN LIEU OF ALL OTHER WARRANTIES, EXPRESSED OR IMPLIED, WRITTEN OR ORAL, INCLUDING ANY WARRANTY OR MERCHANTABILITY, OR FITNESS FOR A PARTICULAR PURPOSE. No employee, agent, dealer or other person is authorized to give any warranties on behalf of Refrigerating Specialties, nor to assume, for Refrigerating Specialties, any other liability in connection with any of its products.