

**TOP VIEW**

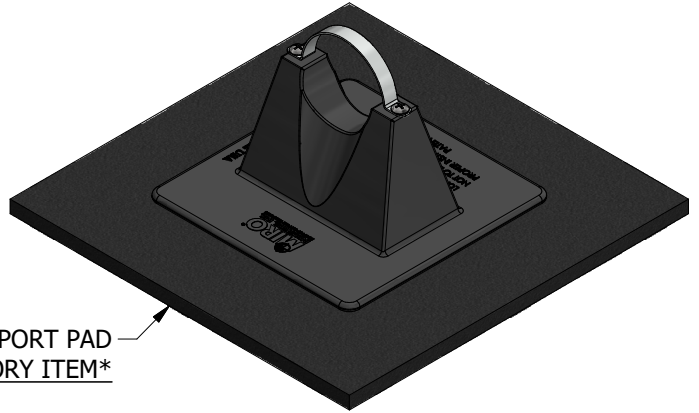

**ISOMETRIC VIEW**

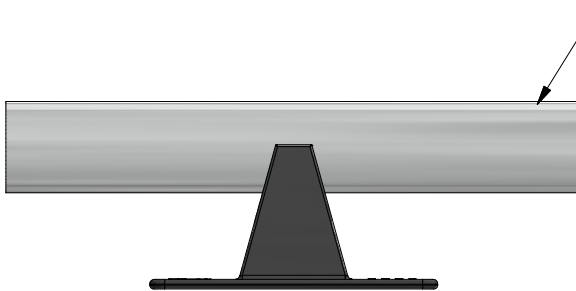

**SIDE VIEW**

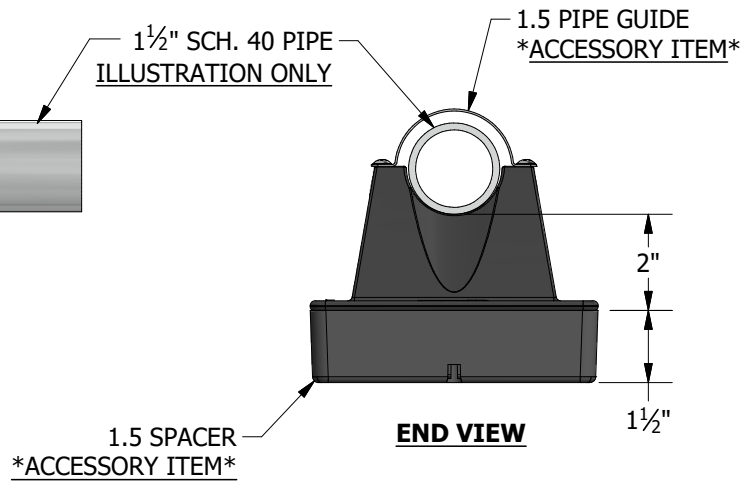

**END VIEW**

**ACCESSORIES**

- 1.5 pipe guide
- 1.5 spacer
- 12x12 Support pad
- Eternabond® 2-sided tape

**PRODUCT DESCRIPTION**

A pipe support used to support roof-mounted gas pipes, electrical conduit, solar piping and other mechanical piping. Unique design absorbs thermal expansion and contraction of pipes thus preventing damage to the roof membrane. Pipes rest in a 'U' shaped cradle situated in a polycarbonate resin base.

**KEY INFORMATION**

- Support is optimized to carry up to a 1 1/2" pipe.
- Maximum pipe OD for the support is 1.9".
- Pipe clearance is 2"
- Maximum load is 72 lbs. based on 3.0 psi to the roof deck. Even load required.
- 63 per case, 22 lbs. per case, (DW= 14 lbs.)
- Recommended spacing is not to exceed 7' centers depending upon the load. Make certain each pipe support is properly elevated to evenly distribute weight at all pipe support locations.
- Base Material: Polycarbonate
- 20 Year Warranty